



**Eddyfi
Technologies**
Beyond current

Getting Started with **VERSATRAX™ 150**



Table of Contents

About This Manual.....	4
Description of Equipment.....	4
Intended Use.....	5
System Power.....	6
Power Requirements.....	6
Generators / Inverters.....	6
Safety.....	6
System Setup.....	8
Working and Storage Environment.....	8
ICON™ Portable Controller Connection.....	8
Vehicle & Tether Connection.....	8
Mini-Reel Setup.....	8
Vehicle Configuration.....	9
General Vehicle Assembly: One, Two or Three Tracks.....	9
Traction Wheel Setup – All Sizes.....	10
Onyx Skid Brush Adjustment.....	11
Onyx Skid Installation:.....	12
Spectrum 45 Camera Installation.....	13
Drop Camera Configuration:.....	14
Vehicle Cable Management.....	14
Optional Traction Arm Springs.....	15
Operation.....	16
Tether Handling.....	16
Pre-Operations Check.....	16
Post-Operations Check.....	17
Power-Up Sequence.....	17

ICON™ Software.....	18
Maintenance.....	18
Connector Care.....	18
Impulse Connector: Lubrication and Cleaning.....	18
Fuse Replacement.....	19
Scheduled Maintenance and Servicing.....	19
Daily.....	19
Weekly.....	19
Troubleshooting.....	20
Video Problems.....	20
Vehicle Problems.....	20
Reel Problems.....	21
Parts & Repairs.....	22
Ordering Parts/Customer Service.....	22
Warranty Repairs.....	22
Factory Returns to Canada.....	22
Product/System Drawing Package Availability.....	23
Limited Warranty Policy.....	23

About This Manual

This manual has been prepared to assist you in the operation and maintenance of your Eddyfi Technologies equipment. Correct and prudent operation rests with the operator who must thoroughly understand the operation, maintenance, service, and job requirements. The specifications and information in this manual are current at the time of printing.

This product is continually being updated and improved. Therefore, this manual is meant to explain and define the functionality of the product. Furthermore, schematics or pictorials and detailed functionality may differ slightly from what is described in this manual.

Eddyfi Technologies reserves the right to change and/or amend these specifications at any time without notice. Customers will be notified of any changes to their equipment.

Information in this manual does not necessarily replace specific regulations, codes, standards, or requirements of others such as government regulations.

This manual copyright © 2023 by Eddyfi Robotics Inc. All rights reserved.

Description of Equipment

The VersaTrax™ I50 is a portable pipe inspection system which utilizes one to three tracks in an inline configuration with integrated traction control arms to fit in a 50-100mm (2-4 inch) pipe range. The vehicle comes standard with an Onyx™ camera and will support an optional Spectrum 45™ pan-and-tilt camera with on-board LEDs to facilitate visual inspections in 78-102mm (3-4 inch) pipe sizes. The vehicle can be configured to use one, two or three tracks, depending on distance. All VT-I50 hardware can be used underwater and in dirty, muddy conditions. The rugged design ensures a long service life and helps protect the vehicle from damage during normal use.

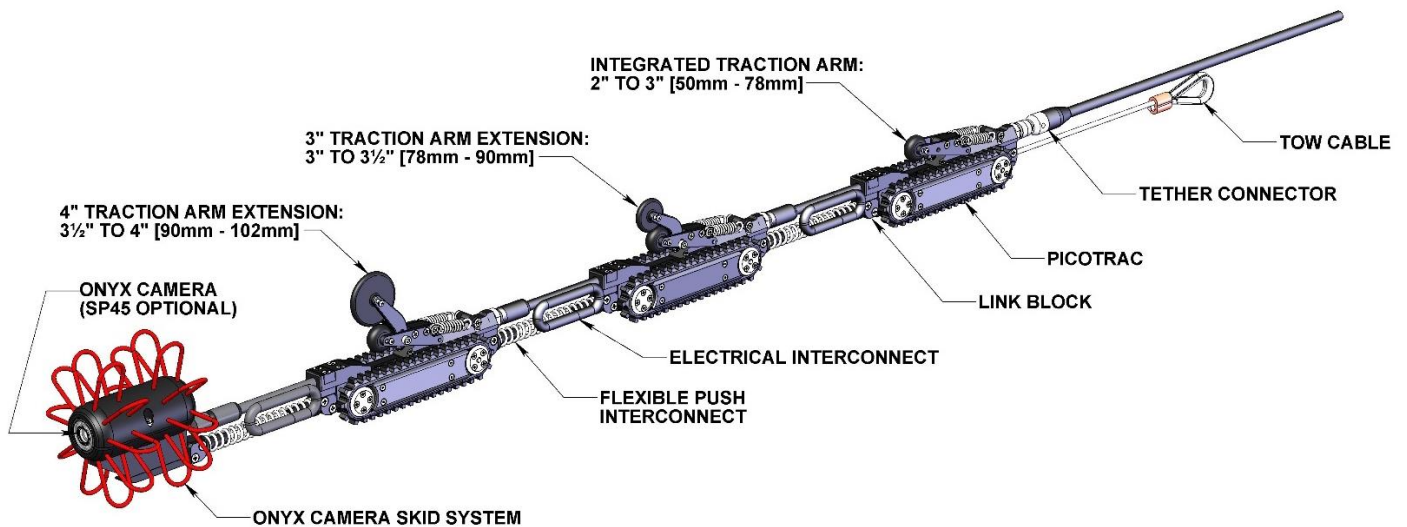

Document: UMBU014988.docm	Revision: A08	Created by: AS	Date: 13 Oct 2023	IPN: 3080215-A08
Source Location: C:\ePDM\ISLEng\products\bu-vt50\vehicles\manuals\UMBU014988.docm				Page 4 of 23

Intended Use

The VT-I50 is an industrial inspection vehicle intended for pipe inspections to provide close-up video of the inspection target. The vehicle may be used above or below the waterline up to 60m deep, or in dry environments. VT-I50 has been designed to support a modular approach by allowing the operator to configure the vehicle in one, two and three track configurations. The VT-I50 system can also be configured as a Spectrum 45™ or Onyx™ Drop Camera.

Typical applications include:

- Sewer and storm drains
- Air ducts
- Steam headers
- Tanks and pressure vessels
- Pulp and paper mills
- Oil & gas refineries and pipelines

Misuse of the system is deployment in a situation for which it is not rated, or incorrect handling.

- a. In a vacuum.
- b. Beyond its depth rating without factory approval.
- c. Above or below its temperature rating.
- d. Use in a potentially explosive atmosphere.
- e. Use in incompatible chemical environments.
- f. Very high radiation environments (Beta/Gamma).
- g. Prolonged overload (payload or pulling load).
- h. Camera pointed at the Sun or at intense lighting.
- i. Mechanical impacts & scraping during deployment / dropping.

Document: UMBU014988.docm	Revision: A08	Created by: AS	Date: 13 Oct 2023	IPN: 3080215-A08
Source Location: C:\ePDM\ISLEng\products\bu-vt50vehicles\manuals\UMBU014988.docm				Page 5 of 23

System Power

Power Requirements

The VT-I50 is operated through an **ICON™ Portable Controller** which provides power to the tether and vehicle.

Refer to the ICON™ Portable Controller User Manual for power input specifications.

Generators / Inverters

If powering the system from a generator or inverter, refer to that unit's operating manual for recommendations on continuous and peak load ratings. These power sources may apply a reduced output rating based on electrical load and environmental temperature. Remember to include the power needs of all other connected devices (external monitors, recording devices, lighting, etc.) when selecting a generator or inverter.

Safety

To use this product properly and safely, every user must first read these operating instructions and observe the safety instructions contained therein. Take care of these operating instructions and keep them in a place where they can be accessed by everyone. Untrained personnel should not handle or operate this equipment.

This system includes some specific devices that have their own User Manuals. Instructions on those manuals must be also read before using the system.



CAUTION: Failure to follow these safety instructions may result in injury or equipment damage.



WARNING: Intense Optical Radiation - The VT-I50 camera lights are extremely bright. Never look directly at the lights. Use a welding filter (shade #8 or higher) if inspecting the LEDs.



WARNING: Spark Hazard - Under no circumstances should this equipment be used in a potentially explosive atmosphere.



WARNING: Trip Hazard - Never stand on the tether. A snap load to the tether may pull it out from underneath you and cause you to fall. Standing on the tether

Document: UMBU014988.docm	Revision: A08	Created by: AS	Date: 13 Oct 2023	IPN: 3080215-A08
Source Location: C:\ePDM\ISLEng\products\bu-vt50vehicles\manuals\UMBU014988.docm				Page 6 of 23

may damage its internal conductors, cause unnecessary wear, and decrease its life.



WARNING: Mechanical Pinch Hazard – Rotating or moving components can draw fingers into a pinch position. Do not handle the vehicle while mobile parts are running, turn off power or disconnect the tether while reconfiguring or maintaining the vehicle.



WARNING: High Voltage 36-70 VDC. Disconnect the power source before servicing the product; otherwise, damage may result.



- Eddyfi Technologies' equipment is used in many varied environments from hot/dry to confined spaces to deep underwater. Such diverse environment risks must be addressed by the operators who are trained to work in such surroundings. As such, the operator is responsible to determine safe site setup and appropriate work procedures for deployment and operation of the equipment.
- Do not operate the camera with a damaged connector or cable. Inspect connectors and cables regularly for damage.
- Lay the vehicle on its side if you are powering it up on the workbench.
- All personnel operating or maintaining this equipment must be trained and competent.
- Call the Eddyfi Technologies service department for assistance or service if needed.

System Setup

Working and Storage Environment

The **ICON™ Portable Controller** is to be used in a **dry, covered** environment only. These components are not waterproof. Keep all cords and cables away from water. Read the **ICON Portable Controller** user manual for more details.

The tether and vehicle are depth rated to 60 meters (200 feet) of water. The tether connector and track connectors are dry-mate types which must be dry when making a connection. Keep the tether connector capped with a dummy plug when not connected to the vehicle to help keep out dirt. The tracks are tolerant to sandy and muddy conditions, although this decreases seal life. The vehicle may also be operated in dry or dusty environments in the recommended operating temperature range of 0 °C – 50 °C (32 °F – 122 °F).

The portable reel is splash resistant only.

System storage temperatures are between -20 °C to 60 °C (-4 °F to 140 °F).

ICON™ Portable Controller Connection

The **ICON™ Portable Controller** supplies power to the tether and vehicle. It provides a communication interface to the vehicle. It also provides video reception and distribution.

Refer to the Controller Setup section of the **ICON™ Portable Controller User Manual** for more information.

Vehicle & Tether Connection

It is important that the tether be properly connected to the vehicle; otherwise, damage to the system may result.

1. Connect the vehicle end of tether to the back of the harness block. Visually line up the key in the connector before mating. Fully screw down and finger-tighten the locking collar. Do not use tools to tighten the IE55 collar – connector damage may occur if overtightened.
2. Verify that the track and camera whips are securely connected to their respective components, and that the whips are free from damage.

Mini-Reel Setup

If your system includes a Mini-Reel, follow these steps to operate:

1. Remove the Mini-Reel from the shipping case.
2. Connect the deck cable from the reel to the **ICON™ Portable Controller**.
3. **Disengage** the shipping brake.
4. Make sure the friction brake is **engaged** – disengaging the friction brake can result in slack tether, resulting in potentially jamming the reel.
5. Unwind some tether and connect the tether to the vehicle.

Document: UMBU014988.docm	Revision: A08	Created by: AS	Date: 13 Oct 2023	IPN: 3080215-A08
Source Location: C:\ePDM\ISLEng\products\bu-vt50vehicles\manuals\UMB014988.docm				Page 8 of 23

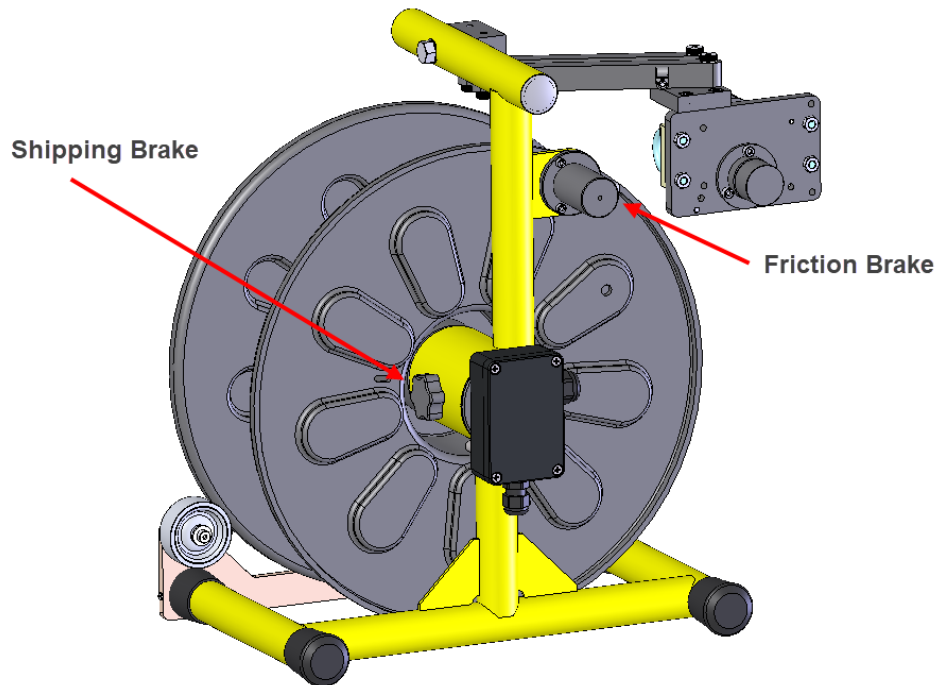

Vehicle Configuration

General Vehicle Assembly: One, Two or Three Tracks

The VT-I50 ships disassembled for portability. Its modular design can easily be configured to operate with **one, two or three** tracks, or in a camera only drop configuration.

To assemble the basic vehicle with one, two or three tracks, and with reference to the illustration below:

1. Remove tracks, camera, and push links from their respective shipping containers.
2. Lay out the components on the bench in order.
3. Attach the tow cable to the rear track:
 - a. Remove the retainer clip located underneath the connector.
 - b. Insert the tow cable anchor into the housing.
 - c. Fasten retainer back on.
4. For two or three-track configurations, link to the next track using a flexible push link. The push link will install between tracks in the same way the tow cable was attached above. Connect the integrated interconnect cable to the next track.
5. Link to the camera using another flexible push link. Connect the integrated interconnect cable from the front track to the camera.
6. Install the appropriate traction wheels and camera skids as discussed in the sections below.

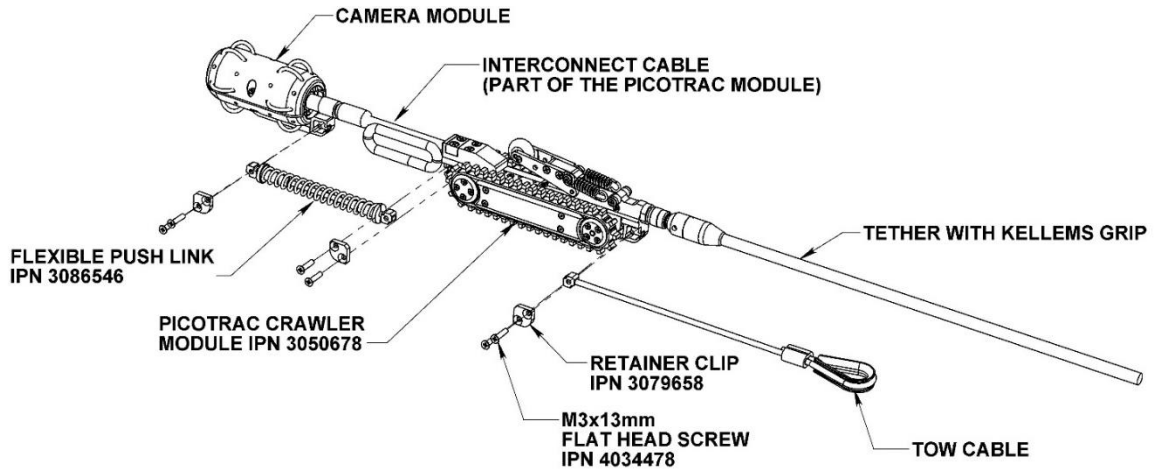

Traction Wheel Setup – All Sizes

Because the tracks are very light, it always requires a pressure wheel to gain traction. The integrated traction arm is preconfigured for use in 2 – 3in [50mm – 78mm] pipe. For larger pipes, the integrated traction arm remains in place but is augmented by an extension wheel which bolts into a slot in the traction arm.

For 3 – 3½in [78mm – 90mm] pipe use the 3-inch traction arm. (IPN 3089224)

For 3½ – 4in [90mm – 100mm] pipe use the 4-inch traction arm. (IPN 3089227)

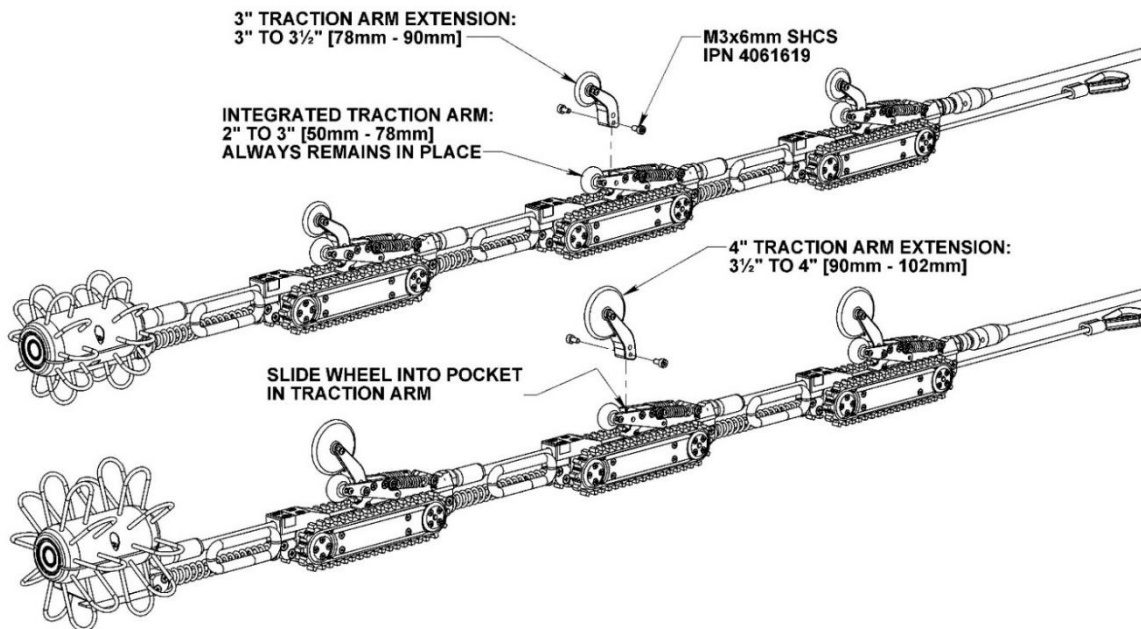

Onyx Skid Brush Adjustment

The Onyx camera skid uses looped nylon cord which act as flexible skids. The flexible structure allows the skid to pass obstacles and around corners in the small, confined pipe which may not be possible with hard, fixed skids. In addition, the nylon loops can be easily resized or replaced. The following procedure describes how to make new bristles for the guide brushes to adapt to any specific size.

Brushes may be custom fit using the following procedure:

1. Cut nylon line to length as outlined below or as needed for a specific size pipe.
2. Melt one end of the trimmer line ~1/8" [3mm] with a small torch, lighter or candle.
3. Blunt the melted end with a flat-head screwdriver.
4. Thread the line from inside the sleeve.
5. Form a loop and thread back through sleeve.
6. Blunt the second end to secure the nylon wire.
7. The finished camera skid must be loose in the pipe as illustrated or it will be too hard for the vehicle to push. Test the fit in a sample pipe before deployment.

Nominal Pipe Size (SCH-40)	Nylon Cord Length (Ø0.095 inch / Ø2.4mm)	Preassembled Skid Part Number
2-Inch [50.8mm]	1.31 inch [33mm]	IPN 3089268
2½-Inch [63.5mm]	1.81 inch [46mm]	IPN 3089269
3-Inch [76.2mm]	2.31 inch [59mm]	IPN 3089270
3½-Inch [90.2mm]	2.84 inch [72mm]	IPN 3089277
4-Inch [102mm]	3.34 inch [85mm]	IPN 3089278

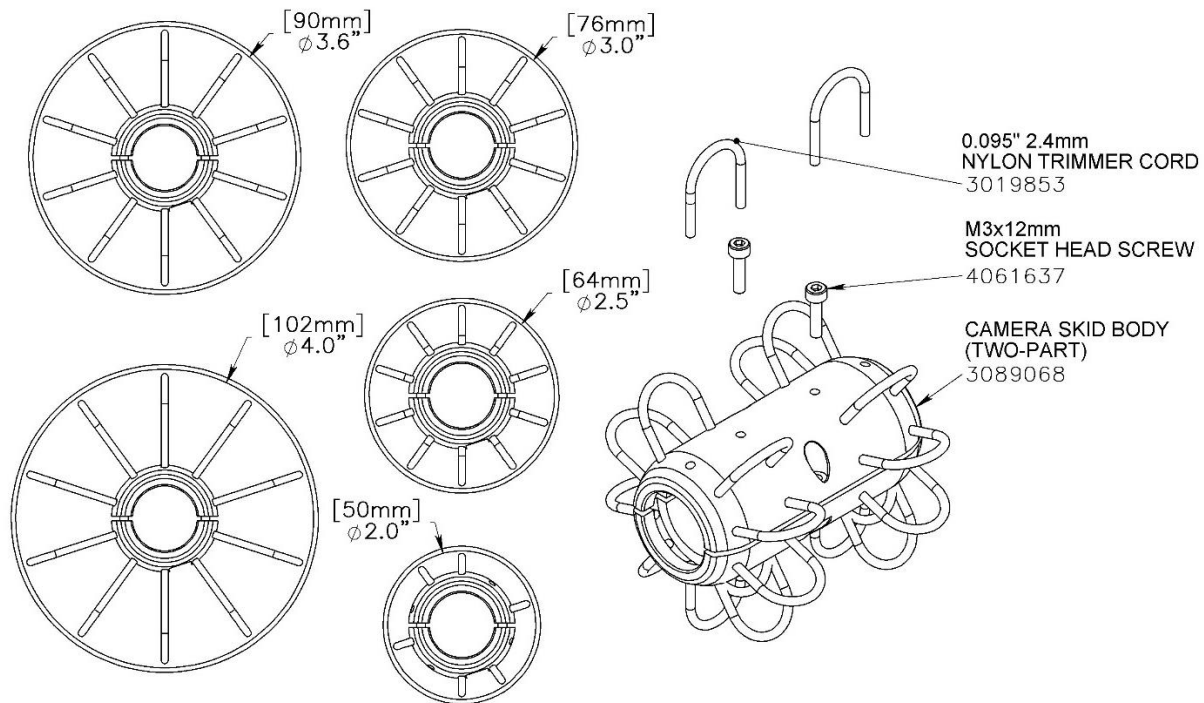

Onyx Skid Installation:

An Onyx™ camera is supplied standard with the VT-I50 system. To install the camera onto the vehicle, and with reference to the figure below:

1. Configure the camera skid brushes for the target pipe size as described in the previous section “Onyx Skid Brush Adjustment.”
2. For 2 and 3-inch pipe [50mm – 76mm] attach the lower half of the two-part skid body to the skid mount using M3x6mm socket head cap screws.
3. Attach the skid mount to the flexible push link connected to the front track.
4. For unified integration, the Onyx camera head is supplied with an IE55 termination adapter which allows it to plug into the interconnect cable on the front track. Ensure the adapter is fully screwed onto the camera body. Attach the camera to the interconnect cable on the front track.
5. Power up the system so the operator can observe the video on the screen.
6. Place the Onyx camera into the skid with the face flush with the front of the skid. Rotate the camera so the image is level. Install the top half of the two-part skid body using M3x12mm socket cap screws. Avoid over-tightening these screws because they are anchored in plastic.

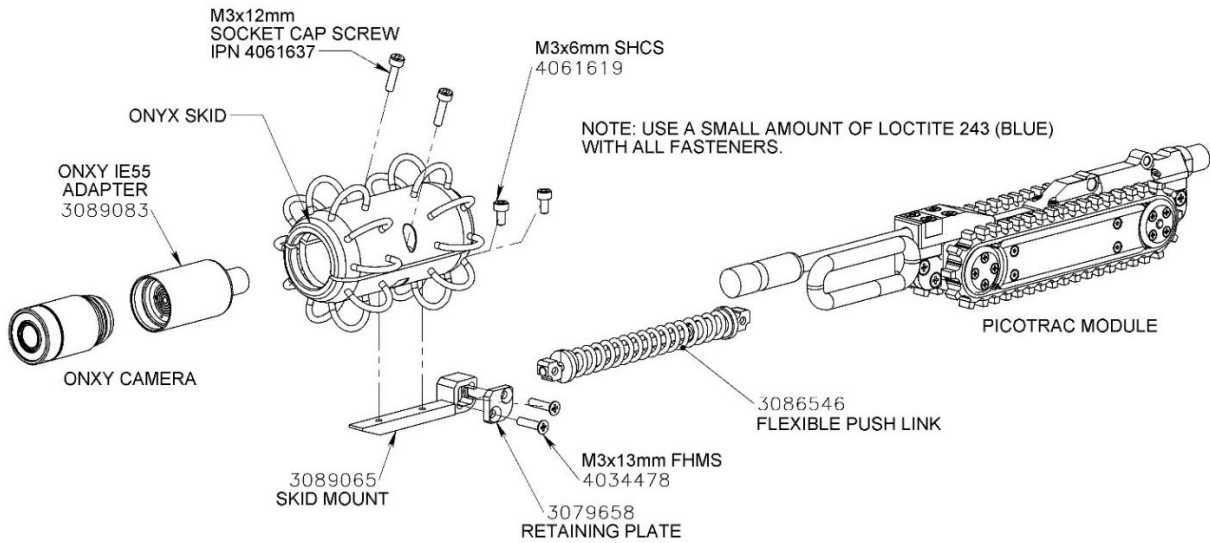

- For 3½ - 4-inch pipe [90-102mm] add the spacer block IPN3089256 between the skid and skid mount, as illustrated below. This will help reduce the up/down torque on the camera skid caused by level mismatch between the skid and push link, which is always at the same level at the bottom of the pipe.

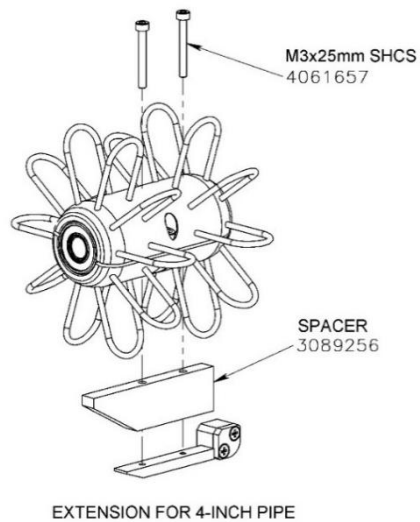

Spectrum 45 Camera Installation

The optional Spectrum 45™ camera is supplied with a 3-inch skid and mounting block.

- Secure the mounting block to the camera using M3x12mm socket head cap screws.
- Attach the flexible push link on the vehicle to the camera mounting block.

Document: UMBU014988.docm	Revision: A08	Created by: AS	Date: 13 Oct 2023	IPN: 3080215-A08
Source Location: C:\ePDM\ISLEng\products\bu-vt50vehicles\manuals\UMBU014988.docm				Page 13 of 23

3. Install the skids using M3x10mm socket head cap screws. Note the orientation of the skid in the figure below. A groove at the back of the skid captures it onto the camera mounting block, while an open slot at the front allows for camera pan motion.

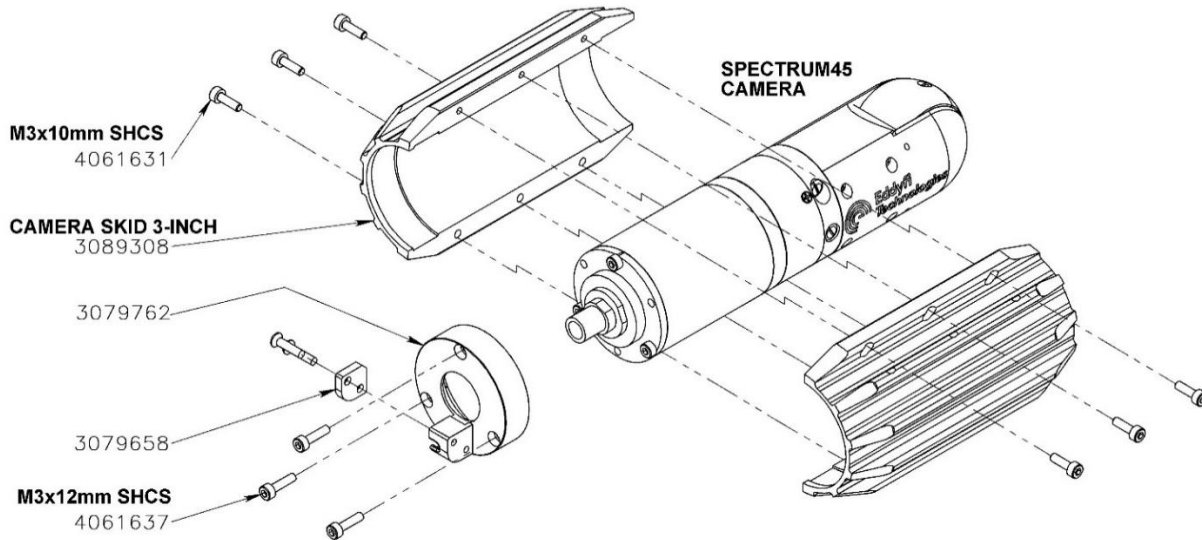

Drop Camera Configuration:

The Onyx camera and optional Spectrum 45 camera may be connected directly to the end of the tether to form a drop camera system.

1. Remove the camera and tow cable from the vehicle or shipping box.
2. Connect the tether to camera – make sure to align pins on connectors and blow out any moisture or debris. Snug down the locking collar finger tight only – do not use tools on the miniature connector.
3. Attach the tow cable to the cable grip on the tether using the quick link supplied. Ensure the load is taken by the tow cable, and there is slack at the connector.

Vehicle Cable Management

For the connector whips between the tracks and between the front track and camera, it is recommended that the connector cable be looped and strapped to the push interconnects using standard cable ties as shown below:



Optional Traction Arm Springs

The spring-loaded VT-I50 traction arms have been optimized for a 2in [50mm] pipe size. If additional traction is required in the larger pipe sizes, stiffer springs (P/N 3050836) may be installed as follows:

1. Remove all four spring hangers and standard springs.
2. Fasten one end of each spring to the forward spring hanger (on the traction arm) and screw down flange.
3. Using a thin screwdriver or pick, stretch the other end of the spring onto the rear spring hanger and screw down flange.
4. Use Loctite 243 (blue) with all the screws.

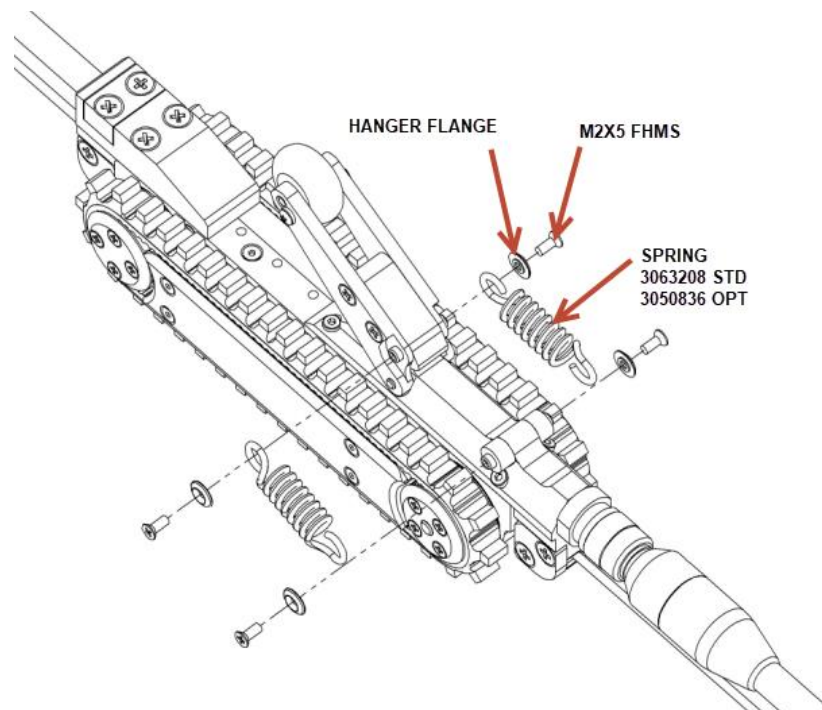

Operation

Tether Handling

The tether is one of the most important parts of the system. It feeds power and control signals to the system and returns data to the controller. If the tether is damaged from: improper use, poor handling or an accident, the system may become inoperable. This could lead to significant downtime, loss of production, and avoidable costly repairs. It is encouraged to stress the importance of the tether and its use to anyone operating or maintaining the equipment. For maximum tether life and reliability, we recommend the following tether handling tips.

- Do not crush the tether by stepping on it.
- Never allow anyone to drive over the tether!
- Do not bend the tether beyond its minimum bend radius.
- Do not kink the tether.
- Do not snap load the tether.
- Avoid loading the tether whenever possible.
- Always use the Kellems grip strain relief if applicable to your system.
- Regularly inspect the tether for damage.
- Regularly clean the tether.

Note: Protecting the conductors inside the tether is critical to the life and operation of the tether. Proper tether handling and care will result in extended tether life and system reliability.

Pre-Operations Check

Before each deployment of the VT-I50 system, ensure everything is completed on the following checklist.

- Check that the work area has been safely set up.
- Check that the line voltage available at the worksite matches the equipment setup.
- Check that power and deck cable connections are correct.
- Check the vehicle for the following:
 - Check that the vehicle is in the correct configuration for the deployment.
 - Check the vehicle for mechanical damage to the chassis or cable harnesses which could affect its operation.
 - Ensure that all fasteners are in place and secure.
 - Visually inspect the vehicle and tracks to ensure that the moving parts are free of debris and functional. Make sure the track belt is free of debris and turns freely.
 - Check the tether and vehicle whips for damage.
 - Ensure camera and light ports are clean.
- Check the reel for the following:

Document: UMBU014988.docm	Revision: A08	Created by: AS	Date: 13 Oct 2023	IPN: 3080215-A08
Source Location: C:\ePDM\ISLEng\products\bu-vt50vehicles\manuals\UMBU014988.docm				Page 16 of 23

- Check that the Shipping Brake is disengaged, and the Friction Brake is engaged.
- Check that the tether has no loose, dangling coils. Dangling coils can propagate as the drum rotates and have the potential to jump the drum. Take care of these before deploying the tether.
- ☐ Power up the system and check the following:
 - Check for sufficient SSD drive space for recording.
 - Check record directories are set.
 - Test video recording.
 - Test track control.
 - Test camera control.

Post-Operations Check

A Post-Ops inspection should be carried out after every deployment using the following checklist:

- ☐ Inspect the tether for damage as it is reeled in.
- ☐ Visually inspect vehicle for entrained debris or mechanical damage.
- ☐ Test each function to ensure proper operation.
- ☐ Clean the system by hosing it down with water at regular line pressure. Do not pressure wash. The tracks may be cleaned off by hosing them down while running. If the system has been used in salt water, thoroughly rinse the vehicle with fresh water right away.
- ☐ Take time to pack the system properly for transport away from the worksite.
- ☐ Store the system in a dry environment.

Note: Ensuring the VT-I50 system is always stored in good working condition will minimize deployment time for future inspections.



CAUTION: Do not use a pressure washer to clean the camera. Very high-pressure water can push past seals and flood the camera resulting in personal injuries from electrical shorts.



Power-Up Sequence

After all wiring connections have been made (as per ICON™ Portable Controller User Manual), the system may be powered up. The recommended sequence for power-up is as follows:

1. Power on System (“SYSTEM” button)
2. Power on Controller (“CONTROLLER” button).
3. Power on embedded PC (“PC” button).

Document: UMBU014988.docm	Revision: A08	Created by: AS	Date: 13 Oct 2023	IPN: 3080215-A08
Source Location: C:\ePDM\ISLEng\products\bu-vt50vehicles\manuals\UMBU014988.docm				Page 17 of 23

4. Start the ICON control (Controller) program.

ICON always begins with identification of attached system components (cameras, tracks, etc.). If vehicle power is turned on after ICON is started, the system will not function until ICON is powered down and restarted.

ICON™ Software

Vehicle control, video recording and export are accomplished using ICON graphical interface controller software. The manual for ICON is integrated into the software or available in PDF format on the control computer's desktop.

- ICON Manual – Accessed through ICON or Desktop Shortcut.

Maintenance

Connector Care

Connectors are an essential part of system reliability. They must be properly maintained and cared for to ensure long life and reliability. We recommend the following steps to help prevent damage and increase the life of connectors.

- Always use connector caps when available.
- Always inspect the end of the connector prior to engaging to ensure it is clean and is the correct match to the mating connector.
- Never plug in a dirty connector.
- Visually align keyways or locating pins prior to engaging the connector.
- Always fully engage or tighten the connector.
- Secure locking collars finger tight only. Tools can result in over-tightening which may damage the connector.
- Install dummy plugs on unused connectors.
- Disconnect by pulling straight, not on an angle.
- Do not pull on the cable to disengage the connector.



Important: Never “Hot Plug” any connector, this will result in internal damage to the electronics. Power down the system prior to plugging in any vehicle or tether connector.

Note: Never use WD-40 or similar solvent-based fluids on connectors or crawlers. These will cause the rubber parts of the connector or crawler to soften and swell rendering them inoperable.

Impulse Connector: Lubrication and Cleaning

- Lubricate mating surfaces regularly with 3M Silicone spray or equivalent, DO NOT GREASE
- Lubricate O-rings with Molykote 111 silicone grease or equivalent.

Document: UMBU014988.docm	Revision: A08	Created by: AS	Date: 13 Oct 2023	IPN: 3080215-A08
Source Location: C:\ePDM\ISLEng\products\bu-vt50vehicles\manuals\UMBU014988.docm				Page 18 of 23

- Use dust caps to protect connectors wherever possible.
- Clean connectors with soap and fresh water, rinse out with alcohol and allow connector to air-dry.

Fuse Replacement

Refer to the **ICON Portable Controller user manual** for information regarding fuse replacement.



Caution: Disconnect the power source before servicing or replacing fuses.

Scheduled Maintenance and Servicing

Track crawlers are designed to provide reliable service accompanied by a minimum downtime for maintenance. The frequency of maintenance and/or repairs will be largely dictated by the type of use and the environments the units are subjected to. We recommend the following maintenance procedures in addition to normal equipment operational inspections.

Daily

Daily or before each use of the VT-I50:

1. Visually inspect the tracks and track belt for damage; if the track belt is torn or stretched it may need to be replaced.
2. Check that the belt tensioning springs are freely moving. This can be done by pulling up on the edge of the track belt with your thumb – the belt should have a small amount of give. If the springs are bottomed out, there may be dirt under the belt which must be removed before deployment to avoid damage and to attain best performance.
3. Visually inspect the tether and interconnect cables for damage. If the cables are damaged the unit should be returned to the factory for servicing.
4. Visually inspect the traction wheels for free movement and roundness. If the wheel is severely damaged or jammed a new one should be installed.
5. Ensure that all fasteners are in place and secure.

Weekly

1. Verify by visual inspection that there are no traces of oil near or on the sides of the drive wheel and the track belt. This would indicate that the oil seals may have been damaged by debris or have become worn by abrasion.
2. If necessary, remove the belt and thoroughly clean the track.

Document: UMBU014988.docm	Revision: A08	Created by: AS	Date: 13 Oct 2023	IPN: 3080215-A08
Source Location: C:\ePDM\ISLEng\products\bu-vt50vehicles\manuals\UMBU014988.docm				Page 19 of 23

Troubleshooting

Video Problems

1. No video (black or blue background).
 - Controller is not turned on.
 - Video cables are not hooked up between controller and monitor.
 - Camera connector on vehicle is loose (turn power off first before plugging in camera).
 - Check monitor input settings.
 - Check for problems with other video components between the controller and monitor.
 - Try a different video cable or auxiliary monitor.
2. Picture is very dark or very bright.
 - Visually check the light levels of the camera.
 - Ensure the camera port window and light windows are clean.
3. Intermittent picture.
 - Check and replace the video cables.
 - Check the monitor is working properly.
 - Check that the camera harness whip is fully plugged in.
 - Check for intermittent breaks in the camera harness cable.
 - Check the tether connectors at both controller and vehicle.
 - Check for tether or slip ring damage by testing tether continuity.
4. Picture is blurry, will not focus, or has poor color.
 - This may be a dirty camera view port, or a narrow object lying close in front of the view port.
 - Object may be too close to the camera.

Vehicle Problems

1. Vehicle runs backward.
 - Track reverse setting incorrect in control software.
 - Node ID conflict between one or more devices on the vehicle.
2. Tracks will not run.
 - Try power cycling the system.
 - Inspect the vehicle wiring for damage.
 - Check all the system connectors.
 - Try restarting ICON™.
 - Listen for the track motors. If the motors run but the track doesn't turn, there is a problem with the gearing or shaft pins.
 - Try changing tracks and update serial number configuration (ICON will require a restart).

Reel Problems

1. Tether distance does not read correctly.
 - Check that the pressure wheel is pressing the tether against the payout sheave. If the tether is being pulled up from the sheave instead of down, it may be disengaged from the sheave.
 - Check that the units are set properly in the graphical overlay.
 - Recalibrate distance encoder.
 - Ensure that the correct COM port is selected in the control software.
2. Intermittent problems with vehicle or camera, only when reel is turning.
 - Slip ring may be damaged. Use a multi-meter to check continuity of the tether with reel drum turning.

Parts & Repairs

Ordering Parts/Customer Service

Some spare and/or replacement parts are available for your product and can be ordered directly from your local office.

When ordering parts, always make sure to quote the sales order acknowledgement (SOA) number and (or) the serial number of the system component in question.

Eddyfi Robotics Inc. (Canadian Headquarters and Manufacturing Location)
 2569 Kenworth Road, Suite C
 Nanaimo, BC, V9T 3M4
 CANADA
 TF 1.877.468.5886
 T +1.250.729.8080
 info@eddyfi.com
 www.eddyfitechnologies.com

Eddyfi Technologies – US (American Authorized Distributor and Service Centre)
 812 W 13th Street
 Deer Park, TX, 77536
 USA
 T +1.281.542.3292
 info@eddyfi.com
 www.eddyfitechnologies.com

Warranty Repairs

Warranty conditions are specified in the Warranty section. Should any conditions of the manufacturer's warranty be breached, the warranty may be considered void. All returned items must be sent prepaid to Eddyfi Technologies at the above address.

Factory Returns to Canada

Some sub-assemblies of your Eddyfi Technologies product are not field-serviceable and may need to return to the factory for repair. Warranty claims must return to the factory for evaluation.

To return an item for evaluation or repair, first contact Eddyfi Technologies at our toll-free number or e-mail address. Eddyfi Technologies will supply a Return Merchandise Authorization (RMA) number with detailed shipping and customs instructions. Items shipped without an RMA number will be held at Eddyfi Technologies until the correct paperwork is completed. If cross-border shipments are not labelled as per the instructions, the items may be held by customs and issued additional fees.

All returned items must be sent prepaid unless other specific arrangements have been made.

Document: UMBU014988.docm	Revision: A08	Created by: AS	Date: 13 Oct 2023	IPN: 3080215-A08
Source Location: C:\ePDM\ISLEng\products\bu-vt50vehicles\manuals\UMBU014988.docm				Page 22 of 23

When the product or system is being shipped anywhere by courier or shipping company, it must be packaged in the original packaging it was received in. This measure greatly reduces the consequences of rough handling and subsequent shipping damage.

Eddyfi Technologies cannot be held responsible for damages due to improper packaging. Shipping damage may have significant impact on repair turnaround times.

Product/System Drawing Package Availability

Mechanical assembly and electrical wiring diagram drawing packages for your equipment are available in PDF format upon request. Printed copies may also be purchased from Eddyfi Technologies. Contact your local sales contact for more information.

Limited Warranty Policy

Refer the Eddyfi Technologies website for warranty terms for this product.

<https://www.eddyfi.com/en/salesterms>

Document: UMBU014988.docm	Revision: A08	Created by: AS	Date: 13 Oct 2023	IPN: 3080215-A08
Source Location: C:\ePDM\ISLEng\products\bu-vt50vehicles\manuals\UMBU014988.docm				Page 23 of 23

The information in this document is accurate as of its publication. Actual products may differ from those presented herein.

© 2024 Eddyfi Canada, Inc. Ectane, and their associated logos are trademarks or registered trademarks of Eddyfi Canada, Inc. in the United States and/or other countries. Eddyfi Technologies reserves the right to change product offerings and specifications without notice. Eddyfi Technologies is a Previa Business Unit.

www.eddyfi.com

info@eddyfi.com



**Eddyfi
Technologies**
Beyond current