

Getting Started with

STIK



Table of Contents

About This Manual	4
System Description	4
Specifications	5
Certification	5
Safety	5
Before You Start	6
System Setup	7
Working And Storage Environment	7
System Power	7
Power Requirements	7
Generators / Inverters	7
ICON™ Portable Controller Connection	8
Spectrum 120HD™	8
Mini-Reel Setup	8
Camera Setup	9
Tether Handling	9
Connector Handling	10
SubConn Connector: Lubrication and Cleaning	10
Hatch Mount Setup	11
Camera Installation	12
Attaching the Mounting Fixture	12
Setting the Pole	13
Automation Extension Camera Setup	14
Overview	14
Setup for Repeatability	14
Camera Height	14
Camera Direction	14

Lighting Conditions	14
Repeatability Setup Example.....	15
Operation.....	16
Inuktun Control – ICON™ & ICON™ RPT	16
Maintenance.....	16
Spectrum 120™ Maintenance	16
Fuse Replacement.....	16
Parts and Repairs	17
Ordering Parts/Customer Service.....	17
Warranty Repairs	18
Factory Returns to Canada.....	18
Product/System Drawing Package Availability	18
Limited Warranty Policy	19

About This Manual

This manual has been prepared to assist you in the operation and maintenance of your Eddyfi Technologies Inuktun equipment. Correct and prudent operation rests with the operator who must thoroughly understand the operation, maintenance, service and job requirements. The specifications and information in this manual are current at the time of printing.

This product is continually being updated and improved. Therefore, this manual is meant to explain and define the functionality of the product. Furthermore, schematics or pictorials and detailed functionality may differ slightly from what is described in this manual.

Eddyfi Technologies reserves the right to change and/or amend these specifications at any time without notice. Customers will be notified of any changes to their equipment.

Information in this manual does not necessarily replace specific regulations, codes, standards, or requirements of others such as government regulations.

This manual is copyright © 2019 by Eddyfi Robotics Inc. All rights reserved.

System Description

The Inuktun STIK™ is a Spectrum Tank Inspection Kit configuration option for the Spectrum 120HD™ (SP120HD) camera and a powerful solution for hatched tank inspections. Adequate and reliable tank inspection is in growing demand. Therefore, the STIK comes equipped with all the necessary components to complete your inspections in a safe, reliable, timely, and cost-effective solution. By eliminating confined space entry, providing quick setup time, and a thorough automated inspection software the STIK is the leading industry packaged solution.

The STIK is a hatch mounted tank inspection kit which includes a SP120HD™ camera. This high definition camera mounts to an adjustable pole assembly. The poled camera is then affixed to the hatch mount assembly and is inspection-ready.

The hatch mount assembly is fully adjustable to fit a wide range of openings, while the camera has a long vertical reach to meet a variety of inspection requirements. Furthermore, the STIK utilizes the ICON™ Software which delivers a more thorough inspection solution. Typical applications include:

- Railway tank car inspection
- Underground services inspection
- Other tanks or pipes with vertical manhole access

Document: 3073676-A07.docm	Revision: A07	Approved by: LC	Date: 06 Dec 2017	IPN: 3073676-A07
Source Location: C:\ePDM\ISLEng\products\dr-extentionpole>manuals\IssuedDocuments\3073676-A07.docm				Page 4 of 19

Specifications

Camera	Spectrum 120HD™
Tether Length	100 m (330 ft)
Tether Management Options	Portable Reel, Mini-Reel, or Deck Cable
Hatch Mount Assembly Range	430 – 920 mm (17 – 36 in) ID
Camera Pole Mount	Aluminum assembly with Extension Pole
Controller	ICON™ Portable Controller (IPC)
Operating System	ICON™ Suite
Operating Temperature	0 – 50 °C (32 – 122 °F)
Storage Temperature	-20° – 60 °C (-4 – 140 °F)



Certification

The STIK™ Camera system is built in accordance with the Machinery Directive 2006/42/EC and Electromagnetic Compatibility Directive 2004/108/EC and Directive 2014/30/EU.





Safety

In order to be able to use this product properly and safely, every user must first read these operating instructions and observe the safety instructions contained therein. Take care of these operating instructions and keep them in a place where they can be accessed by everyone. Untrained personnel should not handle or operate this equipment.

	CAUTION: Failure to follow these safety instructions may result in injury or equipment damage.	
---	---	---

This system includes some specific devices that have their own User Manuals. Instructions on those manuals must be also read before using the system.

	WARNING: High Voltage 36-70 VDC. If the equipment is powered from a source other than an Eddyfi Technologies provided controller, the power supplied to the product must have reinforced isolation from the mains with no reference to earth ground.	
---	---	---

- Observe safe lifting practices. For storage and shipping, the STIK™ system is packed in three parts: Controller, Camera and Tether. Each of the three components is either built or packed into a Pelican case with carrying handle. The heaviest case containing the tether and reel is equipped with wheels and extending handle like a suitcase.
- Do not operate the system with damaged wires. A short circuit may damage the power system, telemetry system, cameras, or attached equipment. Exposed wires may also create a shock hazard.
- Disconnect the power source before servicing the product; otherwise, damage may result.
- All personnel operating or maintaining this equipment must be trained and competent.
- Our equipment is used in many varied environments from hot/dry to confined spaces to deep underwater. Such diverse environment risks must be addressed by the operators who are trained to work in such surroundings. As such, the operator is responsible to determine safe site setup and appropriate personal protective equipment (PPE) for operation and maintenance of the equipment.



WARNING: Trip Hazard - Never stand on the tether. A snap load to the tether may pull it out from underneath you and cause you to fall. Standing on the tether may also damage its internal conductors, cause unnecessary wear, and decrease its life.

Before You Start

- Before you start using your inspection equipment, it is highly recommended that you become familiar with it. This includes knowledge of setup, operation, and care and maintenance of the equipment. A good understanding of your equipment will ensure a safer, more thorough inspection with less downtime.
- Before you start using your inspection equipment, it is highly recommended that you become familiar with the ICON™ Software. A full understanding of how to apply this powerful software will allow for quicker inspections with less downtime. Refer to the ICON Software User Manual for detailed setup and operational information.
- Before you start your inspection, it is recommended that you have a pre-operational plan, which is well communicated with all members of the inspection team. This is a good practice and will help ensure a safe and effective inspection.

Document: 3073676-A07.docm	Revision: A07	Approved by: LC	Date: 06 Dec 2017	IPN: 3073676-A07
Source Location: C:\ePDM\ISLEng\products\dr-extentionpole>manuals\IssuedDocuments\3073676-A07.docm				Page 6 of 19

System Setup

Working And Storage Environment

The **ICON™ Portable Controller** is to be used in a **dry, covered** environment only. These components are not waterproof. Keep all cords and cables away from water. Read the **ICON Portable Controller** user manual for more details.

The tether and camera are depth rated to 60 m (200 ft) of water. The tether connector is dry-mate type which must be dry when making a connection. Keep the tether connector capped with a dummy plug when not connected to the vehicle to help keep out dirt. Read the **Spectrum 120™ Camera** user manual for more details.

The portable reel is splash resistant only.

System storage temperatures are between -20 °C – 60 °C (-4 °F – 140 °F).

System Power

Power Requirements

The STIK™ system is operated through an ICON Portable Controller or Interface Box. The interface box provides power to the tether and vehicle.

Power Input: 100 – 240 VAC, 50 / 60 Hz, 5 A.

Generators / Inverters

If powering the system from a generator or inverter, refer to that unit's operating manual for recommendations on continuous and peak load ratings. These power sources may apply a reduced output rating based on electrical load and environmental temperature. Remember to include the power needs of any other connected devices (external monitors, recording devices, lighting, etc.) when selecting a generator or inverter.

Document: 3073676-A07.docm	Revision: A07	Approved by: LC	Date: 06 Dec 2017	IPN: 3073676-A07
Source Location: C:\ePDM\ISLEng\products\dr-extentionpole>manuals\IssuedDocuments\3073676-A07.docm				Page 7 of 19

ICON™ Portable Controller Connection

The ICON Portable Controller supplies power to the tether and vehicle. It provides a communication interface to the vehicle. It also provides video reception and distribution.

Refer to the Controller Setup section of the ICON Portable Controller User Manual for more information.

Spectrum 120HD™

Your system comes equipped with a Spectrum 120HD - refer to this manual for connector handling, best practices, maintenance and troubleshooting.

Mini-Reel Setup

If your system includes a Mini-Reel, follow these steps to operate:

1. Remove the Mini-Reel from the shipping case.
2. Connect the deck cable from the reel to the Video Interface and Power Supply.
3. Connect the encoder deck cable from the reel to the Video Interface and Power Supply (if provided with Mini-Reel).
4. **Disengage** the shipping brake.
5. Make sure the friction brake is **engaged** – disengaging the friction brake can result in slack tether resulting in potentially jamming the reel.
6. Unwind some tether and connect the tether to the camera.

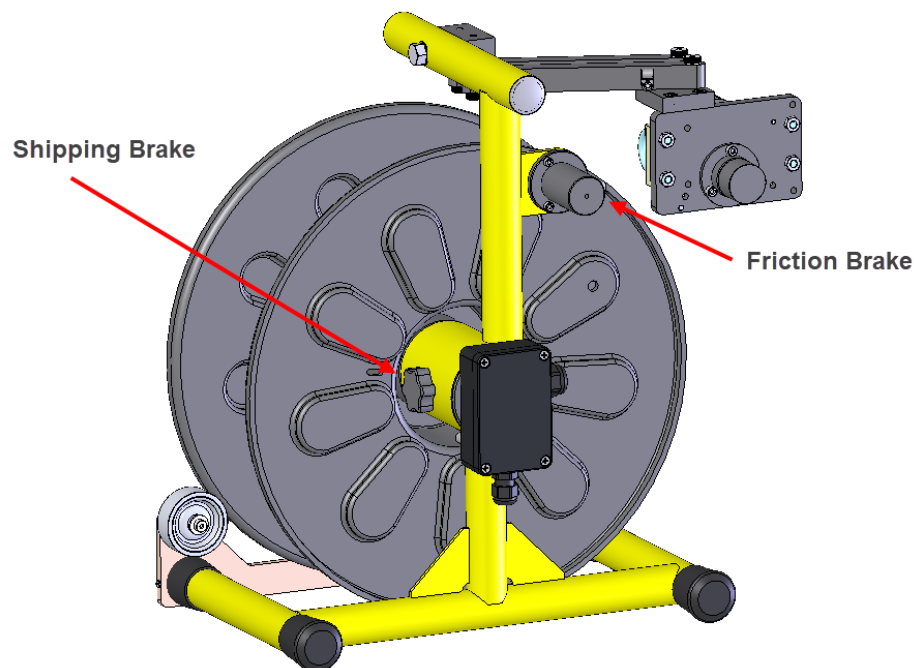

Camera Setup

To set up the camera, you will need to mount the pole mount fixture to the rear of the camera.

1. Remove the skid from the fixture by loosening the 2 skid fasteners at the rear of the skid
Note: The skid may already come separately
2. Secure the pole mount fixture to the rear of the camera by fastening the 3 mounting screws
3. Finally, connect the tether and finger tighten the locking collar



IMPORTANT: Never “Hot Plug” any connector, this will result in internal damage to the electronics. Power down the system prior to connecting the inspection system tether. Always grease the connector and take care as outlined in the next section.

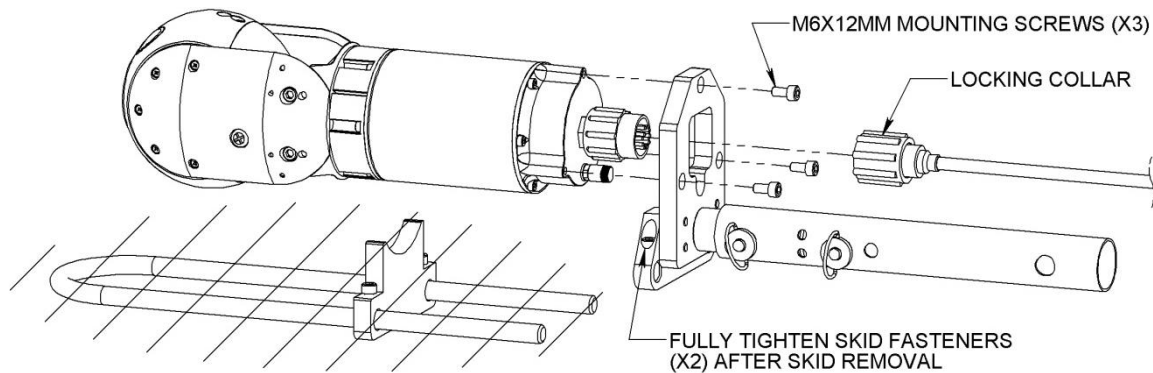

Tether Handling

The tether is one of the most important parts of the system. It feeds power and control signals to the system and returns data to the controller. If the tether is damaged from: improper use, poor handling or an accident, the system may become inoperable. This could lead to significant downtime, loss of production, and avoidable costly repairs. It is encouraged to stress the importance of the tether and its use to anyone operating or maintaining the system. For maximum tether life and reliability, we recommend the following tether handling tips.

- Do not step on the tether
- Do not drive over the tether
- Do not bend the tether beyond its minimum bend radius
- Do not kink the tether
- Do not snap load the tether
- Avoid loading the tether whenever possible
- Always use the cable grip strain relief if applicable to your system
- Regularly inspect the tether for damage
- Regularly clean the tether

Document: 3073676-A07.docm	Revision: A07	Approved by: LC	Date: 06 Dec 2017	IPN: 3073676-A07
Source Location: C:\ePDM\ISLEng\products\dr-extentionpole>manuals\IssuedDocuments\3073676-A07.docm				Page 9 of 19

Note: Protecting the conductors inside the tether is critical to the life and operation of the tether. Proper tether handling and care will result in extended tether life and system reliability.

Connector Handling

Connectors are an essential part of system reliability. They should be properly maintained and cared for to ensure long life and reliability. It is recommended to follow these steps to help prevent damage and increase the life of connectors.

- Always put the cap back on the tether bulkhead when the tether is disconnected
- Always inspect the end of the connector prior to engaging
- Never plug in a dirty or damaged connector
- Visually align key-ways or locating pins prior to engaging the connector
- Always fully engage or tighten the connector
- Secure locking collars finger tight
- Install dummy plugs on unused connectors
- Disconnect by pulling straight, not on an angle
- Do not pull on the cable to disengage the connector

Note: Never use WD-40 or similar solvent-based fluids on connectors or crawlers. These will cause the rubber parts of the connector or crawler to soften and swell rendering them inoperable.

SubConn Connector: Lubrication and Cleaning

- Periodically apply Molykote 111 silicone grease or equivalent before mating connectors
- For dry mate connections, a layer of grease corresponding to 1/10 the socket depth should be applied to the female connector
- After greasing, fully mate the male and female connector and remove excess grease from the connector joint
- General cleaning and removal of sand or mud on a connector should be performed using a spray-based contact cleaner like isopropyl alcohol

Hatch Mount Setup

To set up the hatch mount, make sure your working area is clear and secure of any hazards.

1. Loosen the 2 vertical knobs so that the hatch mount can be expanded
2. Expand the hatch mount to roughly the same diameter as the hatch
3. Place the hatch mount over the hatch with the plastic feet touching the top flange
4. Expand and adjust the hatch mount until all 4 rubber feet make firm contact with the flange walls
5. Finger tighten both knobs to firmly secure the hatch mount
6. Finally, apply a rotational movement to hatch mount to make sure that all 4 rubber feet make firm contact

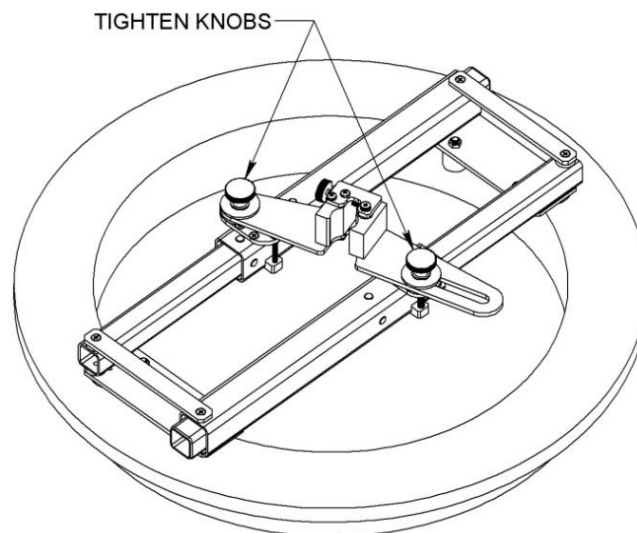
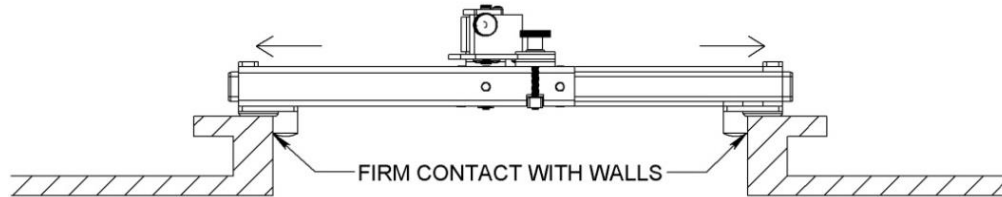
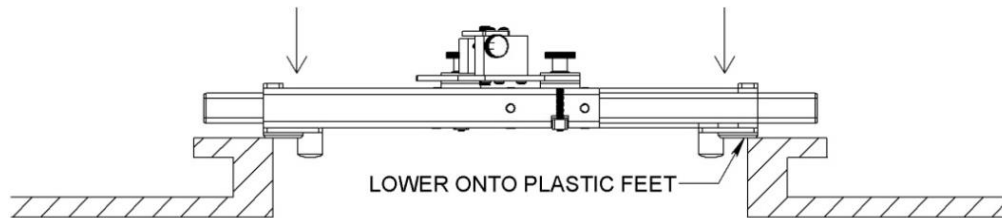

Camera Installation

Before you affix the camera to the hatch mount, make sure your tether is connected and the locking collar is secured. This will act as a retrieval line in case the camera is accidentally dropped. Before you affix the camera to the hatch mount, you will need to decide how far into the tank you would like your camera to be. Add additional poles as needed to achieve the desired reach. Each pole segment adds roughly 1.6 m (64 in). The camera fixture adds roughly 300 mm (12 in) at the mounting face.

Attaching the Mounting Fixture

1. Insert the extension pole into the short pole segment on the camera fixture end
Note: You will need to push down on the button pins while inserting the pole
2. Align the button pins with the appropriate holes and rotate until they snap into place
3. Insert the locking pin for added security
4. Secure tether to the clamp located near the middle of the pole

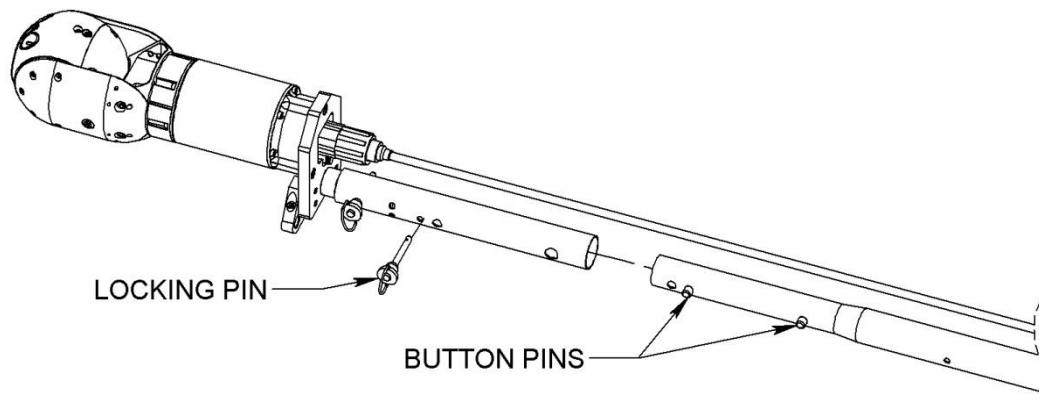

Setting the Pole

1. Loosen off the knob to open the pole-clamping block jaws
2. Insert the pole camera through the open side of the camera clamping block
3. Align pin heads and tether with the open side of the pole clamping block
4. Slide the pole down until it reaches the desired height
5. Tighten the jaw knob while holding onto the pole camera

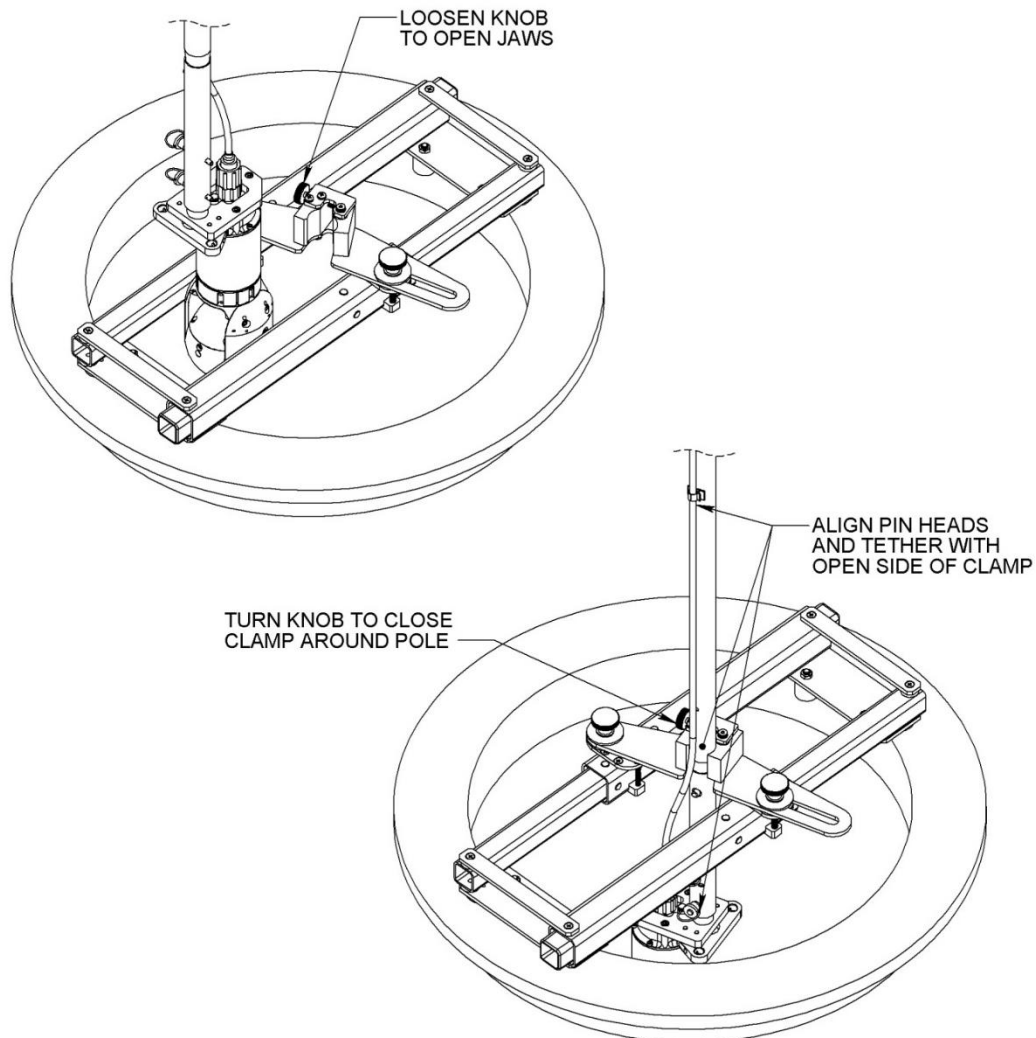

Automation Extension Camera Setup

Overview

The automation software extension is an added feature to the ICON™ Software. This extension utilizes a user defined automation loop sequence allowing a seamless and thorough tank inspection. Furthermore, by performing a repeatable setup operation of the STIK™, the extension can be utilized for a comparative analysis of the same tank over a period. Setup data can be recorded in the job attributes section of ICON. This will ensure that the appropriate data related to a particular tank inspection is not lost. See the ICON Software User Manual for further details regarding the utilization of job attributes in an inspection.

Setup for Repeatability

For the automation routine to be used for a comparative analysis of the same tank over time, the camera needs to be set up the same way every time. Depending on the type of tank that will be inspected a repeatable setup routine has to be devised. There are only three factors that need to be repeated every time.

1. Camera Height - Needs to be the same every time when being deployed into the tank
2. Camera Direction - Needs to be pointing at the same reference direction or point on the tank
3. Lighting Conditions - Needs to be roughly the same as previous inspection



IMPORTANT: The camera needs to be set up consistently for tank job to job data comparison

Camera Height

- Camera depth should be positioned roughly half the distance of the tank height, for instance half way into the tank.
- Record the camera height for each inspection using your own method or the distance markings located on the pole segments.

Camera Direction

- The camera should be positioned in the same direction each time.
- Create a reference point and record it for future use.

Lighting Conditions

- Lighting conditions should be similar in each inspection.
- Cover the Hatch mount so that ambient light doesn't enter the tank.
- Run a sequence and test what light levels work the best for the type of tank.
- Set and record the light levels used on the camera.

Document: 3073676-A07.docm	Revision: A07	Approved by: LC	Date: 06 Dec 2017	IPN: 3073676-A07
Source Location: C:\ePDM\ISLEng\products\dr-extentionpole>manuals\IssuedDocuments\3073676-A07.docm				Page 14 of 19

Repeatability Setup Example

The following repeatability set up example is for a Railway Tank Car. Different tanks will involve a different point of reference and so on. It is recommended that you devise a setup sequence that works well for your application and is easily repeatable.

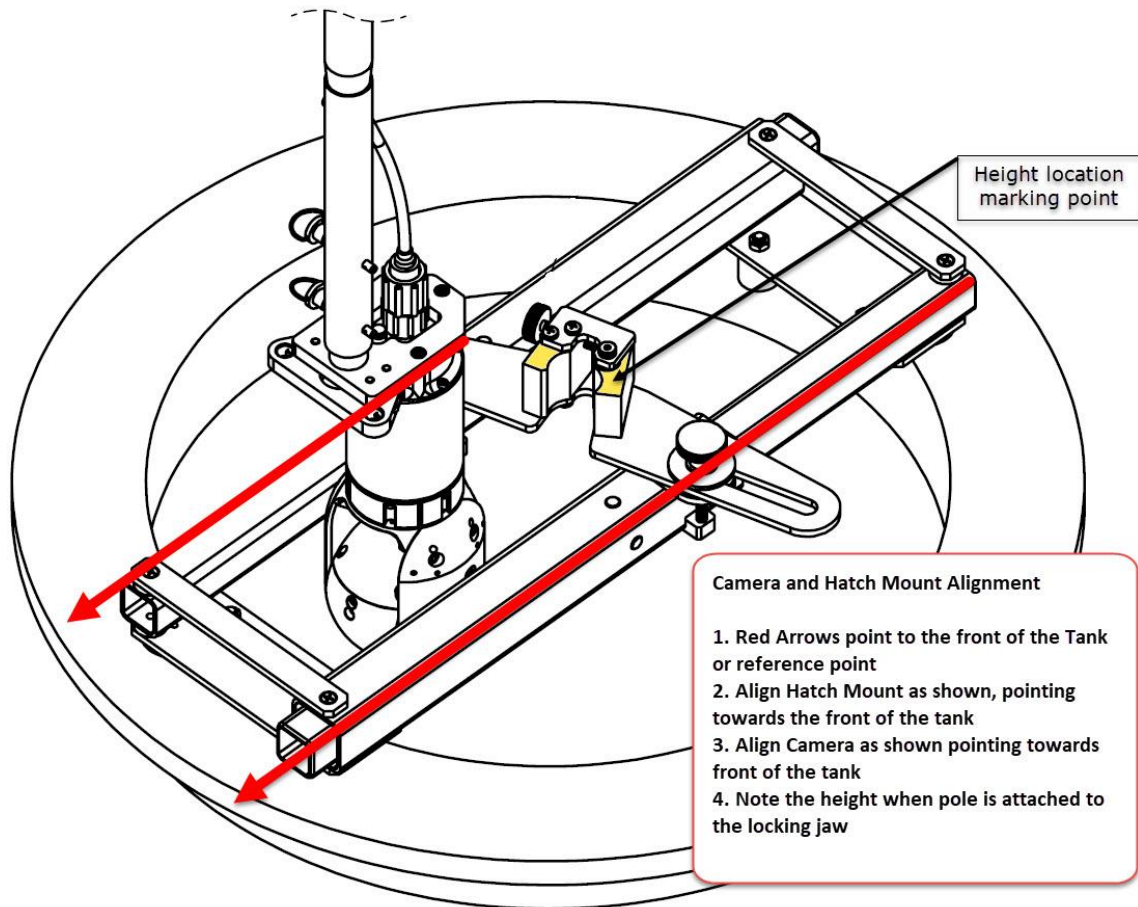

Operation

Inuktun Control – ICON™ & ICON™ RPT

Vehicle control and video recording are accomplished using the ICON graphical interface controller software. Video playback and reporting are conducted through ICON RPT. **Manuals for these two software packages are included separately.** Controls for recording and snapshot functions are kept on-screen with the camera controls.

- ICON Manual – (Control Interface and Recording)
- ICON RPT Manual - (Reporting, Playback and Video Export)

Maintenance

Spectrum 120™ Maintenance

Refer to the Spectrum 120 Camera User Manual for maintenance and servicing instructions.

Fuse Replacement

The controller and power supply contain panel mount fuses for both AC and DC voltages. These fuses are for the safety of the operator(s) as well as to protect the equipment from damage. If a fuse blows, stop and look for possible causes. Causes might include cable damage, water incursion or improper connections. *See the controller manual for fuse replacement.*

Fuse values have been carefully selected for their application. Always replace the fuses with the same type and rating.



WARNING: Disconnect the power source before checking or replacing fuses.



Parts and Repairs

Ordering Parts/Customer Service

Spare and/or replacement parts are available for your product and can be ordered directly from your local office.

When ordering parts always make sure to quote the sales order acknowledgement (SOA) number and/or the serial number of the system component in question.

Eddyfi Robotics Inc. (Canadian Headquarters and Manufacturing Location)

2569 Kenworth Road, Suite C

Nanaimo, BC, V9T 3M4

CANADA

TF 1.877.468.5886

T +1.250.729.8080

info@eddyfi.com

www.eddyfitechnologies.com

Eddyfi Technologies – US (American Authorized Distributor and Service Centre)

812 W 13th Street

Deer Park, TX, 77536

USA

T +1.281.542.3292

info@eddyfi.com

www.eddyfitechnologies.com

Document: 3073676-A07.docm	Revision: A07	Approved by: LC	Date: 06 Dec 2017	IPN: 3073676-A07
Source Location: C:\ePDM\ISLEng\products\dr-extentionpole>manuals\IssuedDocuments\3073676-A07.docm				Page 17 of 19

Warranty Repairs

Warranty conditions are specified in the Warranty section. Should any conditions of the manufacturer's warranty be breached, the warranty may be considered void. All returned items must be sent prepaid to Eddyfi Technologies at the above address.

Factory Returns to Canada

Some sub-assemblies of your Eddyfi Technologies product are not field-serviceable and may need to return to the factory for repair. Warranty claims must return to the factory for evaluation.

To return an item for evaluation or repair, first contact Eddyfi Technologies at our toll-free number or e-mail address. Eddyfi Technologies will supply a Return Merchandise Authorization (RMA) number with detailed shipping and customs instructions. Items shipped without an RMA number will be held at Eddyfi Technologies until the correct paperwork is completed. If cross-border shipments are not labelled as per the instructions, the items may be held by customs and issued additional fees.

All returned items must be sent prepaid unless other specific arrangements have been made.

When the product or system is being shipped anywhere by courier or shipping company, it must be packaged in the original packaging it was received in. This measure greatly reduces the consequences of rough handling and subsequent shipping damage.

Eddyfi Technologies cannot be held responsible for damages due to improper packaging. Shipping damage may have significant impact on repair turnaround times.

Product/System Drawing Package Availability

Mechanical assembly and electrical wiring diagram drawing packages for your equipment are available in PDF format upon request. Printed copies may also be purchased from Eddyfi Technologies. Contact your local sales contact for more information.

Document: 3073676-A07.docm	Revision: A07	Approved by: LC	Date: 06 Dec 2017	IPN: 3073676-A07
Source Location: C:\ePDM\ISLEng\products\dr-extentionpole>manuals\IssuedDocuments\3073676-A07.docm				Page 18 of 19

Limited Warranty Policy

Eddyfi Technologies will repair or replace, at its expense and at its option, any system or component, subject to the limitations and / or exclusions specified herein, which in normal use has proven to be defective in workmanship or material provided that, within one (1) year of the purchase date, the original purchaser returns the product prepaid, accompanied by proof of purchase, from a sales agent authorized by Eddyfi Technologies, and provides Eddyfi Technologies with reasonable opportunity to verify the alleged defect by inspection.

Warranty Limitations and/or Exclusions:

1. This warranty does not apply to light bulbs.
2. Batteries, fuses, transistors, integrated circuit modules (IC's), voltage regulating devices and electrical plugs and / or connectors are warranted to be free from defects in material and workmanship for a period of ninety (90) days from the date of shipment to the original purchaser.
3. Any article purchased from, but not manufactured by, Eddyfi Technologies is sold with only such warranties as are made by the manufacturer therein. Eddyfi Technologies only warrants that it has title thereto, free of all liens or encumbrances.
4. This warranty does not apply to units which are damaged by connection to improperly wired AC receptacles.
5. Track belts, tethers, view ports and other components subject to wear through abrasion are warranted to be free from defects in material and workmanship for a period of ninety (90) days from the date of shipment to the original purchaser.
6. Any damage caused by failure to observe proper packing or to observe instructions for operation and maintenance as contained in the Instruction Manual furnished with the equipment, by accident in transit or elsewhere, will not be covered by the warranty.
7. Repairs are warranted for 90 days.

Eddyfi Technologies may require that certain components may be returned, prepaid, to a manufacturer's authorized station for inspection and repair or replacement.

Eddyfi Technologies will not be responsible for any asserted defect which has resulted from Acts of God, normal wear, misuse, abuse, improper configuration, repair, or alteration made, or specifically authorized by, anyone other than a representative of Eddyfi Technologies authorized to do so. The giving of, or failure to give, any advice or recommendation by Eddyfi Technologies shall not constitute any warranty by, or impose any liability on, Eddyfi Technologies.

The foregoing constitutes the sole and exclusive remedy of the purchaser and the exclusive liability of Eddyfi Technologies and is in lieu of any and all other warranties, express, implied or statutory as to merchantability, fitness for purpose sold, description, quality productiveness, or any other matter. Under no circumstances shall Eddyfi Technologies be liable for special, incidental or consequential damages, or for delay in performance of this warranty.

Document: 3073676-A07.docm	Revision: A07	Approved by: LC	Date: 06 Dec 2017	IPN: 3073676-A07
Source Location: C:\ePDM\ISLEng\products\dr-extentionpole>manuals\IssuedDocuments\3073676-A07.docm				Page 19 of 19

The information in this document is accurate as of its publication. Actual products may differ from those presented herein.

© 2024 Eddyfi Canada, Inc. Ectane, and their associated logos are trademarks or registered trademarks of Eddyfi Canada, Inc. in the United States and/or other countries. Eddyfi Technologies reserves the right to change product offerings and specifications without notice. Eddyfi Technologies is a Previa Business Unit.

www.eddyfi.com

info@eddyfi.com



**Eddyfi
Technologies**
Beyond current