



**Technical
Specifications**

VERSATRAX P-SERIES

Best in Class. Far...and Away

VersaTrax™ is a state-of-the-art robotic architecture providing remote visual inspection (RVI), mobility, and access to confined or difficult-to-access platforms.

REMOTE VISUAL INSPECTION AND MORE

The VersaTrax P-Series is a state-of-the-art pipe inspection system with advanced capabilities. This sophisticated robotic crawler provides detailed remote visual inspection, traveling up to one kilometer (3,300ft) in a single run.

It is well suited for various integrity assessments across a broad range of industries, offering unmatched versatility and flexibility.

The VersaTrax can be utilized for regular maintenance and monitoring campaigns or for quickly troubleshooting a problem in emergencies. The VersaTrax is an essential component of any NDT toolkit requiring remote access visual assessments.

INDUSTRIES

- Petrochemical
- Oil & Gas
- Nuclear
- Mining
- Municipal
- Water

APPLICATIONS

- Tunnels
- Unpiggable pipeline
- Power plant pipeline
- Fresh water line
- Sewer
- FOSAR

**High-tech robots
designed for long-
distance inspections (up
to 1 km/0.6 mi) with a
wide parallel chassis and
gravity-based traction.**



APPLICATIONS

- Tunnels
- Unpiggable pipeline
- Power plant pipeline
- Fresh water line
- Sewer
- FOSAR

TRULY VERSATILE

While VersaTrax crawlers are primarily used for pipeline, tunnel, and trenchless inspections, these versatile robotic crawlers are capable of so much more - their full potential awaits your bespoke application. Adaptable track configuration makes the VersaTrax suitable for both curved pipe and flat surfaces.

The travel distance allows it to be utilized for short or long-range operations. The carrying capacity enables operators to mount additional tools or sensors, and the unique tracks allow continuous usage in harsh and dirty environments.

With a 60m (200ft) depth rating, the VersaTrax family of crawlers are ideal for submerged assessments or wet and humid environments. Say hello to stress-free in-service inspections and painless maintenance schedules.

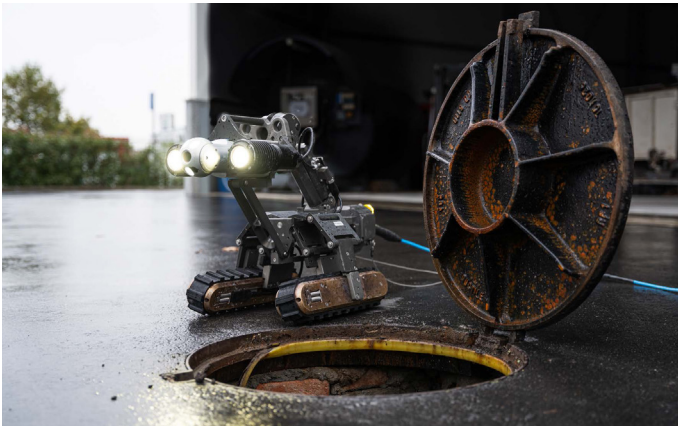

Figure 1: VT-P320, large class crawler, designed for sewer pipe inspections, penstock inspections, and tunnel applications.

LIVE CAMERA STREAM

VersaTrax crawlers are equipped with a robust camera that can stand up to the toughest conditions. Offering a super low latency video stream allows you to easily navigate around obstacles and make instant decisions while the crawler is 1km (0.6m) away.

Many camera options are available, ranging from full Pan, Tilt, and Zoom (PTZ) to the compact PT Spectrum camera.



Figure 2: Remote internal pipeline inspection

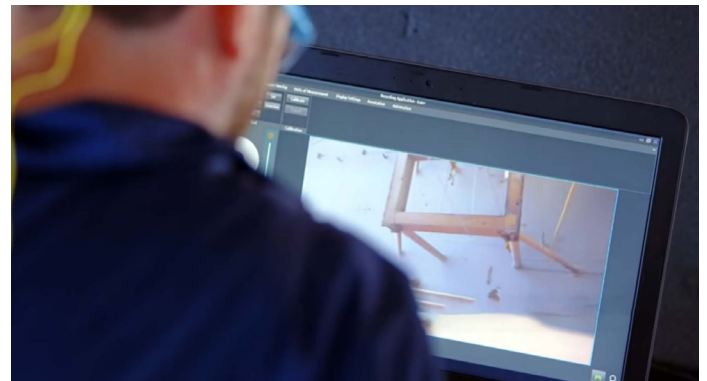

Figure 3: ICON records remote visual inspection video and snapshots, collating the information with sensor data collected from the vehicle mounted sensors with an ICON job.

SIMPLE AND OPTIMIZED INTERFACE

The P-Series utilizes proprietary ICON™ software. Whichever inspection crawler the operator uses, the software interface stays the same, allowing you to reduce the amount of time spent training and flattening the learning curve.

Software features include crawler operation, project/job image tagging and annotation, video recording, sensor data recording, plugins providing automation, and more.

Talk to our experts to discuss which robotic crawler is best suited for your application.

SPECIFICATIONS

	VT-M310	VT-M460
Minimum pipe opening	205mm (8in)	320mm (12.5in)
Maximum tether length	300m (1000ft)	1000m (3300ft)
Maximum speed	9m (30ft) per minute	6.4m (21ft) per minute
Maximum pulling capacity (with weight kit)	8kg (18lb)*	53kg (116lb)*
Vehicle weight	6.8kg (15lb)	45kg (100lb)
Maximum payload (weight)	15kg (33lb)	24Kg (53lb)*
Camera	Spectrum 45 PT camera and rear auxiliary camera	Spectrum 90 PTZ camera and rear auxiliary camera Optional: Spectrum 120 HD PTZ camera and rear auxiliary camera
Controller	IC100 portable controller	IC500 portable controller
Lighting	2x auxiliary LED lights	2x auxiliary LED lights
Depth rating	60m (200ft)	60m (200ft)
Operating temperature	Normal: 0°C to 45°C (32°F to 113°F) Limited: -10° to 45°C (14°F to 113°F)**	Normal: 0°C to 45°C (32°F to 113°F) Limited: -10° to 45°C (14°F to 113°F)**

*Actual payload is affected by surface condition.

**Running outside the normal operating condition for prolonged periods of time can affect system performance and reduce life expectancy of some components.

STANDARD DIMENSIONS

VT-P205

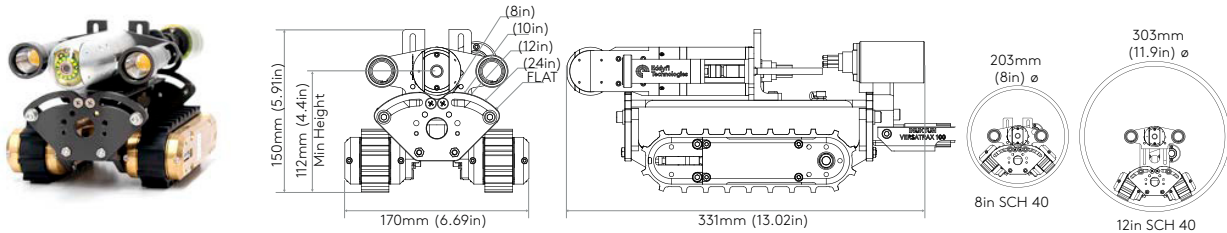

VT-P320

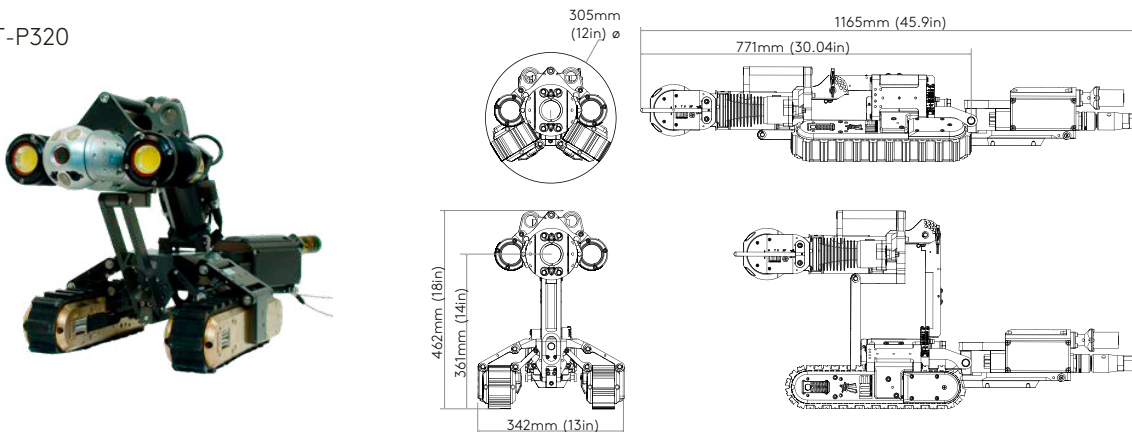

The information in this document is accurate as of its publication. Actual products may differ from those presented herein. © 2024 Eddyfi Canada Inc. VersaTrax, Spectrum, ICON and their associated logos are trademarks or registered trademarks of Eddyfi Robotics. (wholly owned subsidiary of Eddyfi Canada Inc.) in Canada and/or other countries. Eddyfi Technologies reserves the right to change product offerings and specifications without notice. Eddyfi Technologies is a Previa Business Unit