



CIRC-IT

DJ0050 Rev 05.7

Low Profile, Small Diameter Scanner

SAFETY WARNINGS / PRECAUTIONS

KEEP THIS MANUAL – DO NOT LOSE

THIS MANUAL IS PART OF THE **CIRC-IT** AND MUST BE RETAINED FOR THE LIFE OF THE PRODUCT. PASS ON TO SUBSEQUENT OWNERS.

Ensure any amendments are incorporated with this document.



CAUTION! The **CIRC-IT** is designed for a specific use. Using the **CIRC-IT** outside of its intended use could cause damage to the product. Read and understand this manual before using.



WARNING! Can be harmful to pacemaker and ICD wearers. Stay at least 10 cm (4 in) away.



WARNING! DO NOT DISASSEMBLE. No user-serviceable parts. Disassembling any of the components in this product, beyond the instructions in this user manual, could void the regulatory certifications and/or effect the safety of the product.



The **WEEE** symbol indicates that the product must not be disposed of as unsorted municipal waste, but should be collected separately.

(see *Disposal* on page 51)

TABLE OF CONTENTS

1	IDENTIFICATION	1
	1.1. Product Brand.....	1
	1.2. Manufacturer	1
2	Product Specifications	2
	2.1. Intended Use	2
	2.1.1. Operating Limits	2
	2.1.2. Operating Environment	2
	2.2. Dimensions and Weight	3
	2.2.1. Probe Spacing	4
	2.3. Environmental Sealing	6
	2.4. Performance specifications	6
3	Definitions	7
	3.1. Definition of Symbols	7
4	System Components	8
	4.1. Component Identification	8
	4.2. Tools	10
	4.2.1. Included tools	10
5	Preparation for Use	11
	5.1. Scanner Identification (Single Side)	11
	5.2. Scanner Identification (Dual Side)	12
6	Configurations	13
	6.1. Single Probe	13
	6.2. Dual Probe	13
7	Operation	14
	7.1. Setup of CIRC-IT on a Pipe or Tube	14
	7.1.1. Setup on diameters smaller than 31.75 mm (1.25 in)	18

	7.2. Single Probe Scanner Setup.....	19
	7.3. Installing Wedges	20
	7.4. Sleeve Setup	23
	7.5. Setting Wedge Spacing	28
	7.5.1. Wedge Separation Indicators.....	30
	7.6. Switching Crossbars	33
	7.7. CIRC-IT Setup (Single-Sided Access).....	36
	7.8. Latch Connection	40
	7.9. Link Connection	41
	7.9.1. Correct Link Configuration	42
8	Maintenance	43
9	Troubleshooting.....	44
	9.1. Technical Support	44
10	Service and Repair	45
11	Spare Parts	46
	11.1. CIRC-IT Components	46
	11.2. CIRC-IT Scanner	47
	11.2.1. Encoder Connector Type	48
	11.3. Accessories	49
	11.3.1. Crossbars	49
	11.3.2. CIRC-IT Spare Parts Kit	49
	11.3.3. CIRC-IT Spare Wheels Kit	50
12	Disposal	51
13	Limited Warranty	52
14	Appendix	54
	14.1. CIRC-IT Setup Chart	54

IDENTIFICATION

1.1. Product Brand

The CIRC-IT is a manual small diameter, low profile scanner. It is designed to provide encoded probe positioning, circumferentially, around piping and tubing.

1.2. Manufacturer

Distributor:



Manufacturer:

Jireh Industries Ltd.

53158 Range Road 224
Ardrossan, Alberta, Canada
T8E 2K4

Phone: 780.922.4534

jireh.com

PRODUCT SPECIFICATIONS

2.1. Intended Use

The CIRC-IT is a manual small diameter, low profile scanner. It is designed to provide encoded probe positioning, circumferentially, around piping and tubing.

1. The intended scan surface is to:
 - ▶ free of debris, scale, soot, etc
 - ▶ no smaller than 21.3 mm (0.84 in) outer diameter
 - ▶ no larger than 114.3 mm (4.5 in) outer diameter
2. The CIRC-IT is intended for both dual and single probe scanning applications.

2.1.1. Operating Limits

	Minimum	Maximum
Pipe/Tube Range, Outer Diameter:	21.44 mm (0.84 in)	114.30 mm (4.5 in)
Required Radial Clearance:*	11.0 mm (0.433 in)	

* Scanner only. Transducers and wedges not included.

2.1.2. Operating Environment

The CIRC-IT is designed for use in industrial environments that are between -20° C (-4° F) and 50° C (122° F).

2.2. Dimensions and Weight

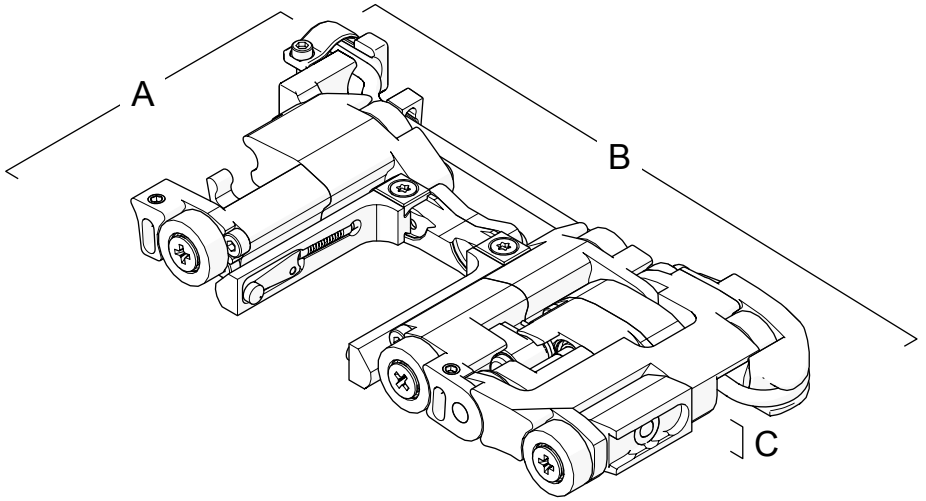

Fig. 1 - Single probe scanner dimensions

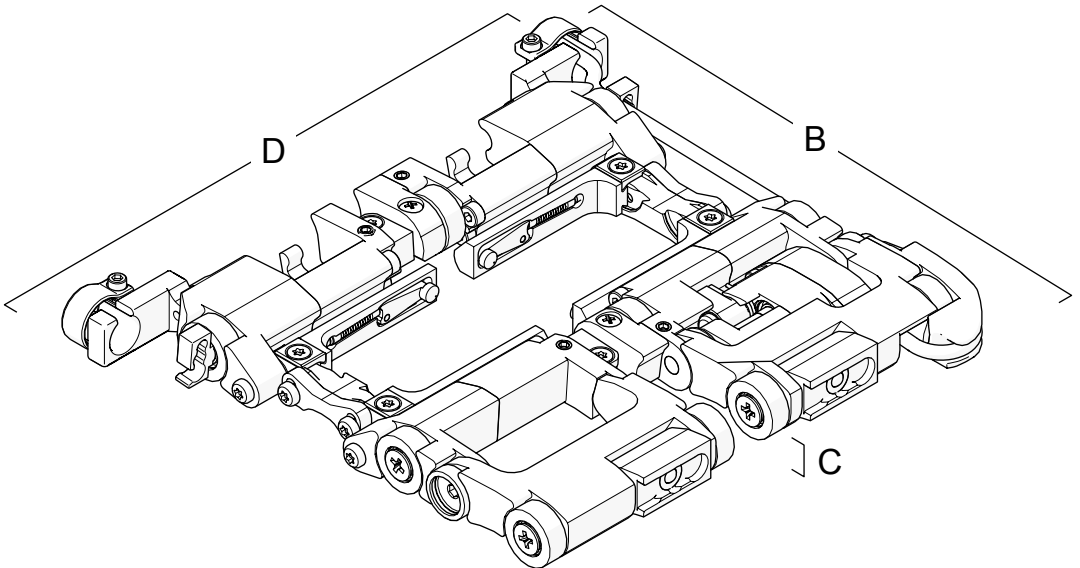

Fig. 2 - Dual probe scanner dimensions

A:	53.5 mm	2.1 in
B:	105.6 mm	4.2 in
C:	11 mm	0.43 in
D:	115 mm	4.5 in

2.2.1. Probe Spacing

- ▶ Using 44 mm (1.7 in) crossbars

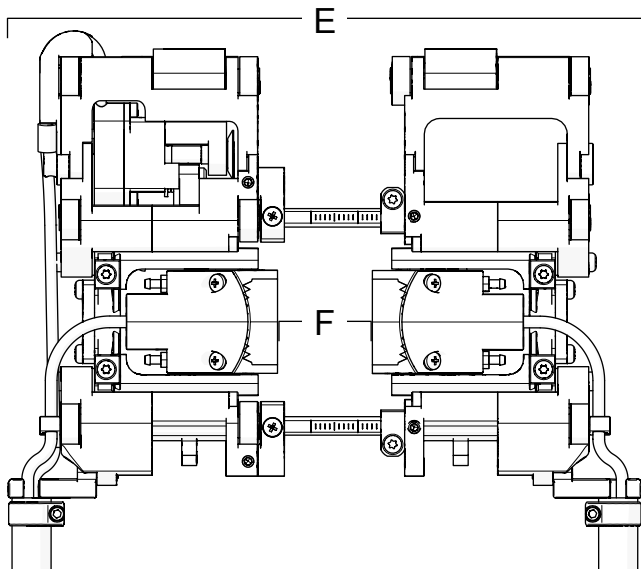

Fig. 3 - 20 mm probe spacing using DJ0034-044 crossbars

- ▶ Using 69 mm (2.7 in) crossbars

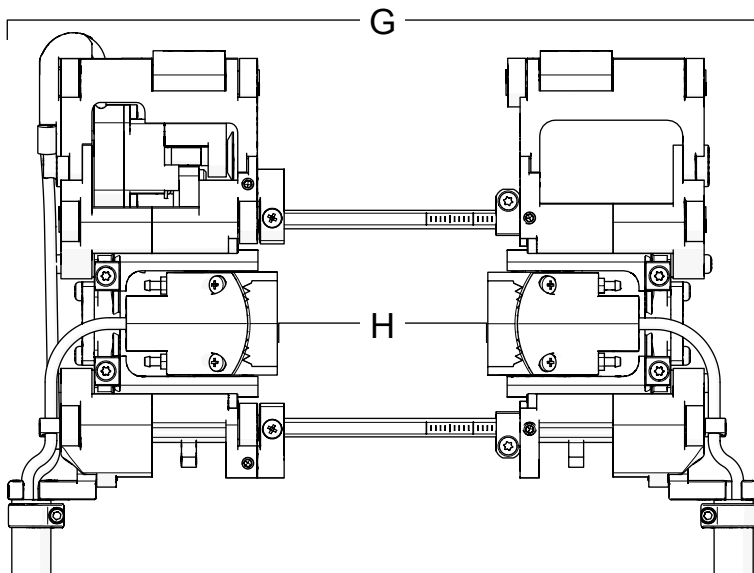

Fig. 4 - 45 mm probe spacing using DJ0034-069 crossbars

- ▶ Using 94 mm (3.7 in) crossbars

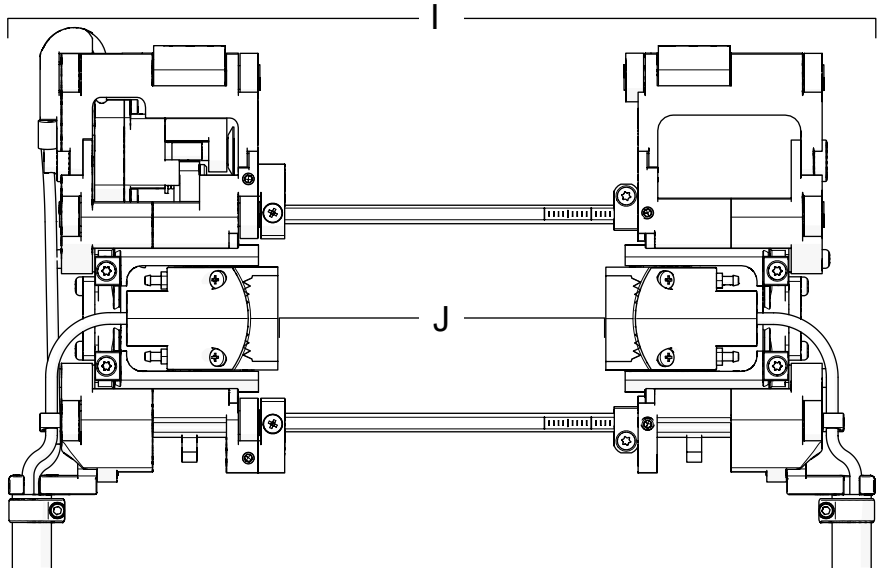

Fig. 6 - 70 mm probe spacing using DJ0034-094 crossbars

- ▶ Using 119 mm (4.7 in) crossbars

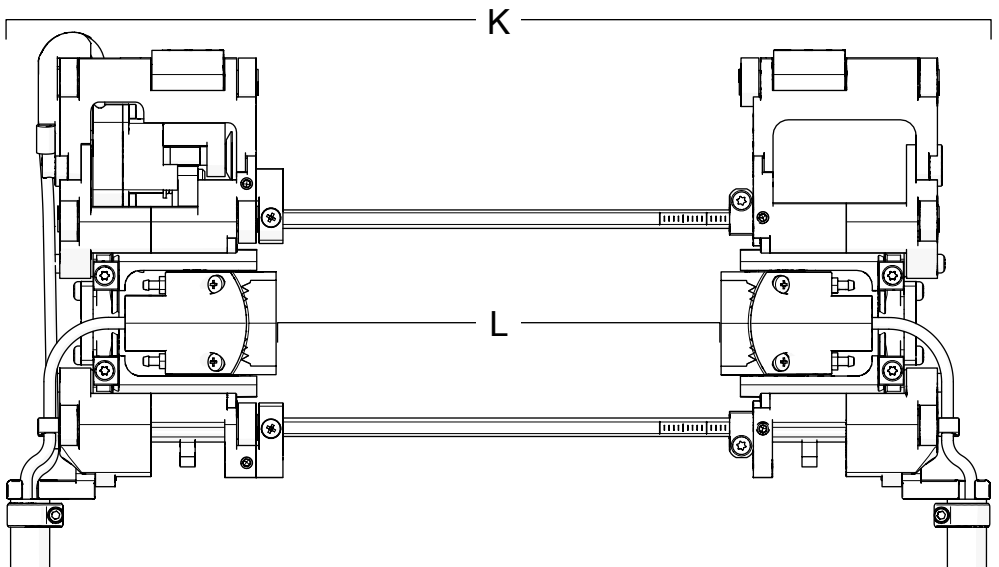

Fig. 5 - 95 mm probe spacing using DJ0034-119 crossbars

	Scanner Width (mm)	Scanner Width (in)	Crossbars
E:	134.6 mm	5.3 in	DJ0034-044
G:	159.6 mm	6.3 in	DJ0034-069
I:	184.6 mm	7.3 in	DJ0034-094
K:	209.6 mm	8.3 in	DJ0034-119

	Probe Spacing (mm)	Probe Spacing (in)	Crossbars
F:	20 mm	0.8 in	DJ0034.044
H:	45 mm	1.8 in	DJ0034-069
J:	70 mm	2.8 in	DJ0034-094
L:	95 mm	3.7 in	DJ0034-119

To switch to various crossbar lengths (see *Switching Crossbars* on page 33)

NOTE: DJ0034-119 crossbars are sold separately.
(contact Jireh Industries Ltd. on page 1)

Single Probe Scanner Weight:	0.09 kg	0.2 lb
Dual Probe Scanner Weight:	.18 kg	0.4 lb
Encoder Cable Length:	3 m	9.8 ft

2.3. Environmental Sealing

Watertight (*submersible*), (contact Jireh Industries Ltd. on page 1 for details)

2.4. Performance specifications

Encoder Resolution:	31.30 counts/mm (795.0 counts/inch)
---------------------	-------------------------------------

DEFINITIONS

3.1. Definition of Symbols



Instructions to 'look here' or to 'see this part'

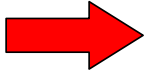

Denotes movement. Instructing user to carry out action in a specified direction.

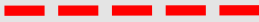

Indicates alignment axis, can also indicate insertion or movement of parts.



Alerts user that view has changed to a reverse angle.

SYSTEM COMPONENTS

4.1. Component Identification

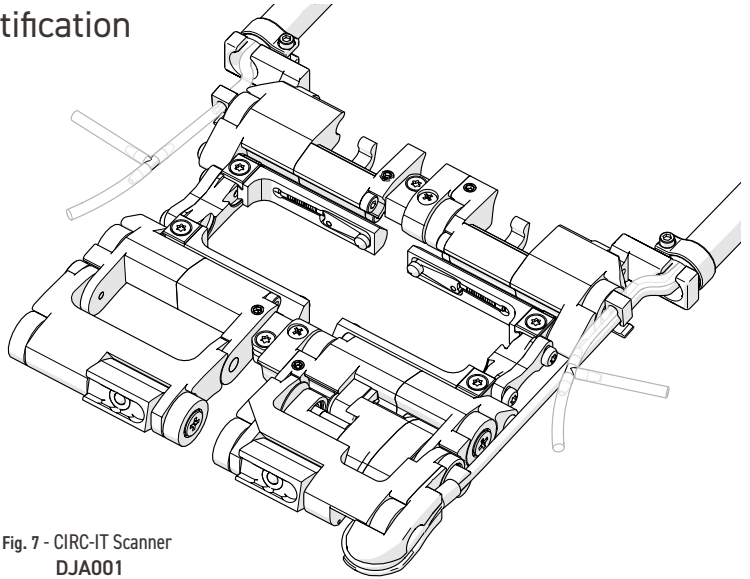

Fig. 7 - CIRC-IT Scanner
DJA001

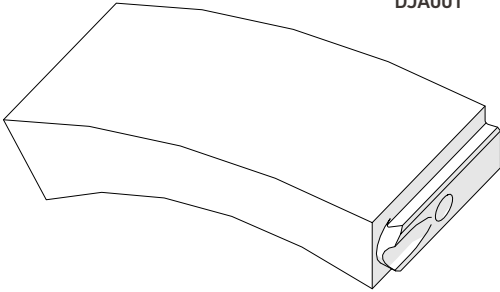

Fig. 8 - Long link
DJS013-1.815

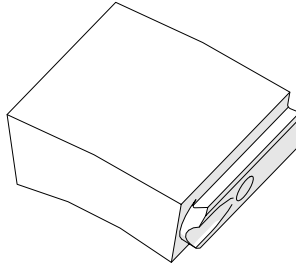

Fig. 9 - Medium link
DJS013-1.125

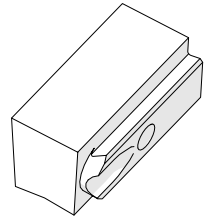

Fig. 10 - Short link
DJS013-0.735

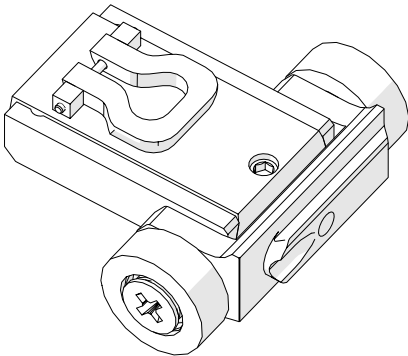

Fig. 11 - Long latch
DJS012

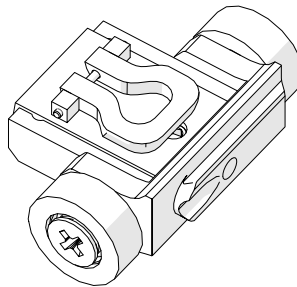

Fig. 12 - Short latch
DJS008

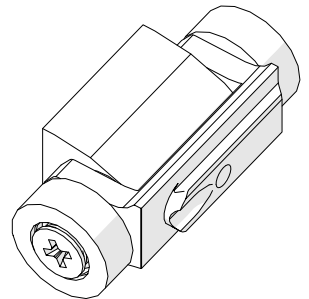
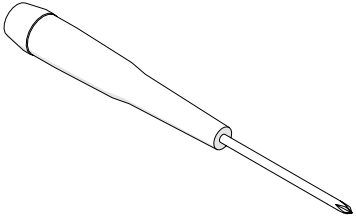
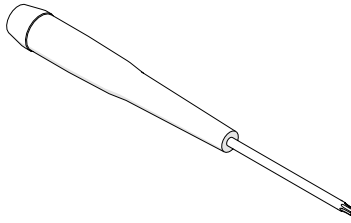

Fig. 13 - Wheel link
DJS006



**Fig. 14 - Philips driver
EA307**



**Fig. 15 - Torx® driver
EA303**

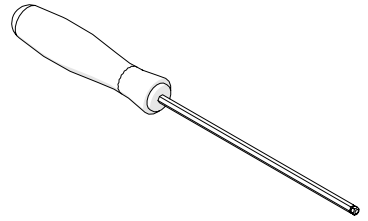

**Fig. 16 - 2 mm hex driver
EA476**

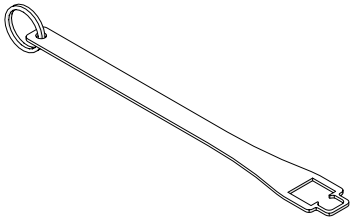

**Fig. 17 - Chain retrieval tool
DJS018**

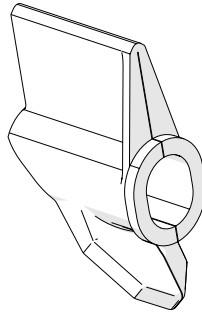

**Fig. 18 - Loom installation tool
EA302**

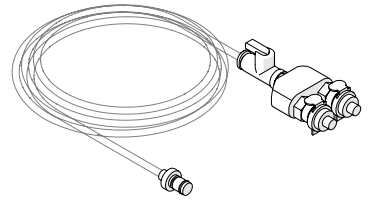

**Fig. 19 - Irrigation splitter
DJS020**

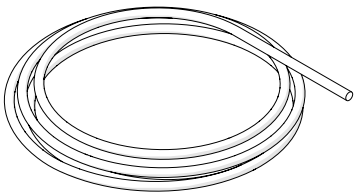

**Fig. 20 - Sleeving
SP035**

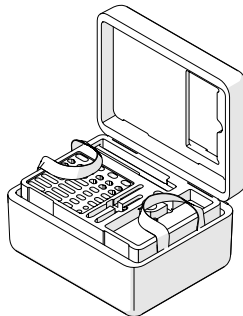

**Fig. 21 - CIRCUIT case
DJA002**

4.2. Tools

4.2.1. Included tools

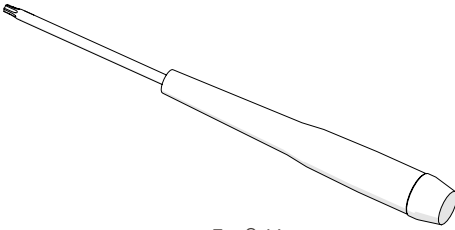

Fig. 22 - Torx® driver

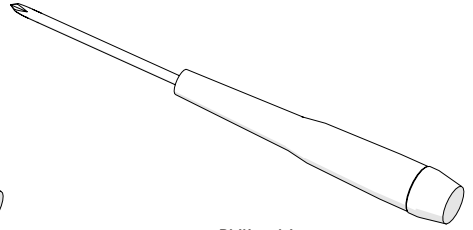

Fig. 23 - Philips driver

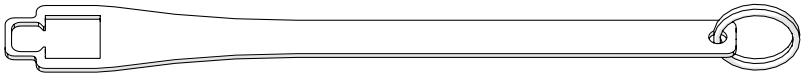

Fig. 24 - Chain retrieval tool

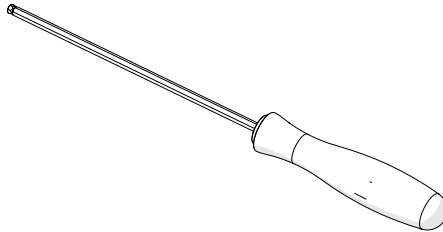

Fig. 25 - 2 mm hex driver

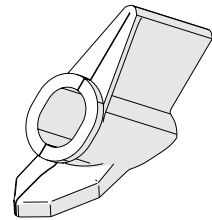

Fig. 26 - Loom installation tool

- ▶ The Torx® driver (*Fig. 22*) is sufficient for typical operations and adjustments of the CIRC-IT.
- ▶ The Philips driver (*Fig. 23*) is sufficient for typical operations and adjustments of the CIRC-IT.
- ▶ The chain retrieval tool (*Fig. 24*) is used when installing the scanner during single sided access situations.
- ▶ The 2 mm hex driver is required for removal of the encoder cable guard.
- ▶ The loom installation tool (*Fig. 26*) is used for setup of the scanner's sleeving.

PREPARATION FOR USE

5.1. Scanner Identification (Single Side)

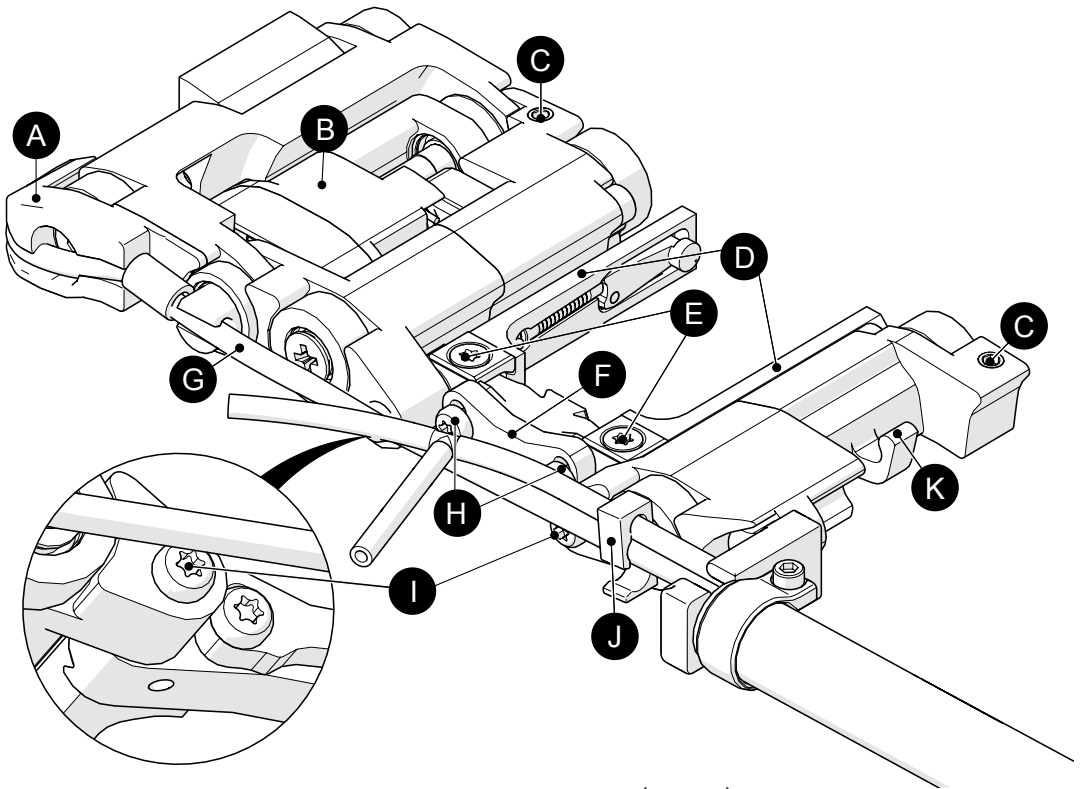

Fig. 27 - Scanner component identification (single side)

A	Encoder Cable Guard	G	Encoder Cable
B	Encoder	H	Setup Tab Screws
C	Crossbar Retaining Screw	I	Pivot Adjustment Screw
D	Probe Holder Arm	J	Cable Management Clip
E	Probe Holder Adjustment Screw	K	Latch Hook
F	Setup Tab		

5.2. Scanner Identification (Dual Side)

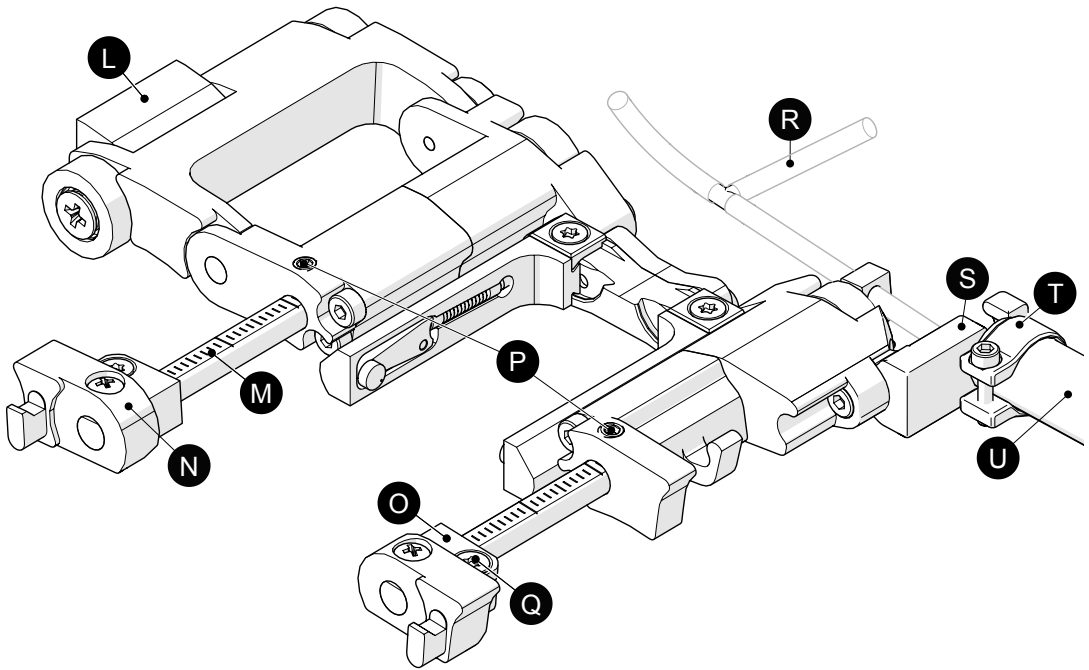

Fig. 28 - Scanner component identification (dual side)

L	Link Mount
M	Crossbar
N	Crossbar Clamp Bracket
O	Wedge Separation Indicator
P	Crossbar Clamp Screw
Q	Wedge Separation Indicator Clamp Screw
R	Irrigation Tube
S	Sleeve Clamp Bracket
T	Sleeve Clamp
U	Sleeve

CONFIGURATIONS

6.1. Single Probe

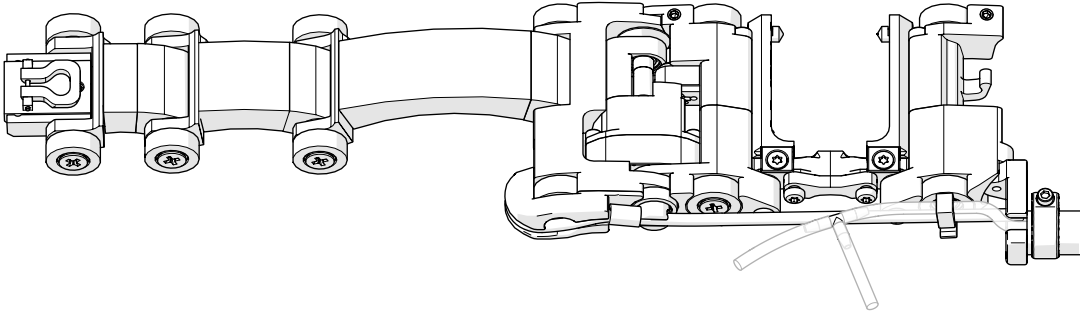

Fig. 29 - Single probe scanning

6.2. Dual Probe

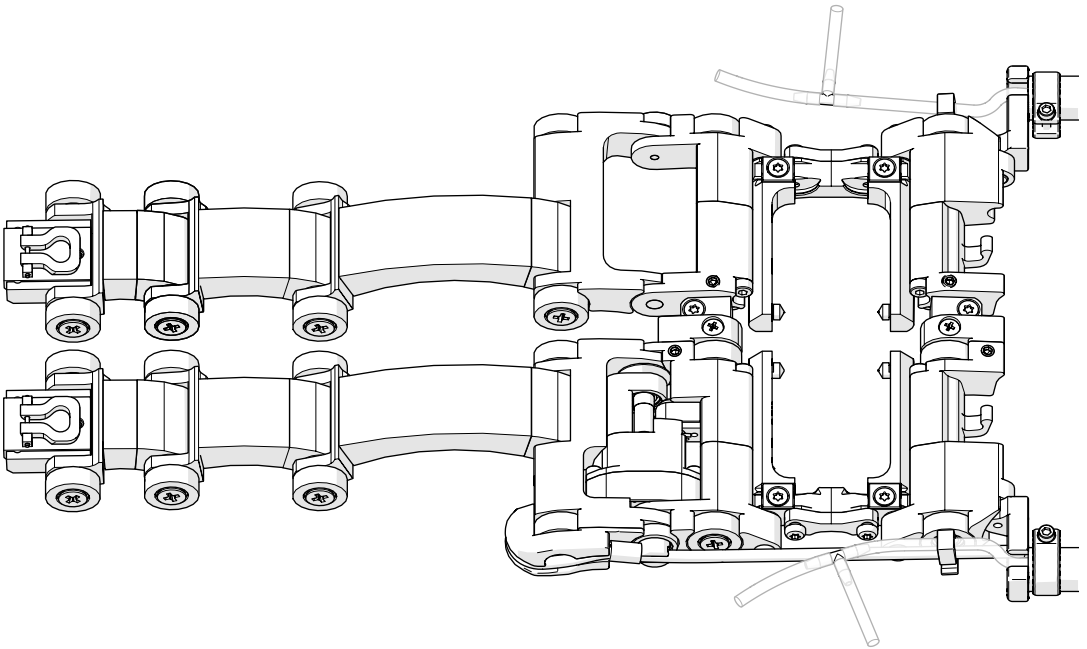

Fig. 30 - Dual probe scanning

OPERATION

7.1. Setup of CIRC-IT on a Pipe or Tube

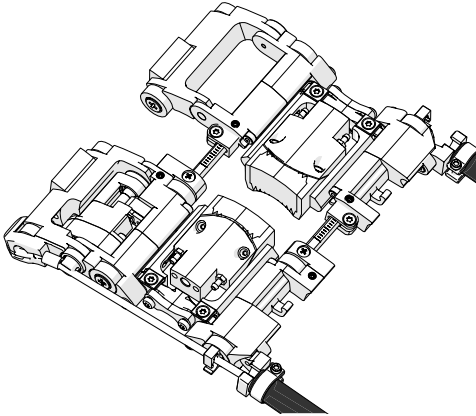
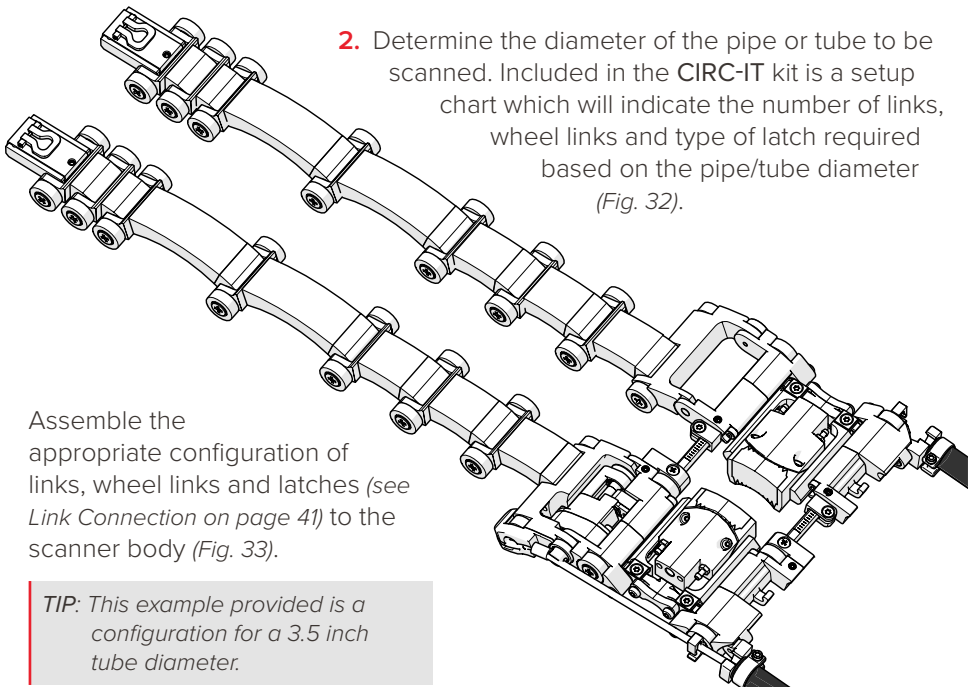

Fig. 31 - Set wedge spacing



Fig. 32 - Refer to setup chart

1. Install the wedges (see *Installing Wedges on page 20*) as well as set the desired probe spacing (see *Setting Wedge Spacing on page 28*) (Fig. 31).



2. Determine the diameter of the pipe or tube to be scanned. Included in the CIRC-IT kit is a setup chart which will indicate the number of links, wheel links and type of latch required based on the pipe/tube diameter (Fig. 32).

3. Assemble the appropriate configuration of links, wheel links and latches (see *Link Connection on page 41*) to the scanner body (Fig. 33).

TIP: This example provided is a configuration for a 3.5 inch tube diameter.

Fig. 33 - Assemble links on a flat surface

NOTE: Alternate wheel links and links ensuring links are always separated by a wheel link (see Correct Link Configuration on page 42).

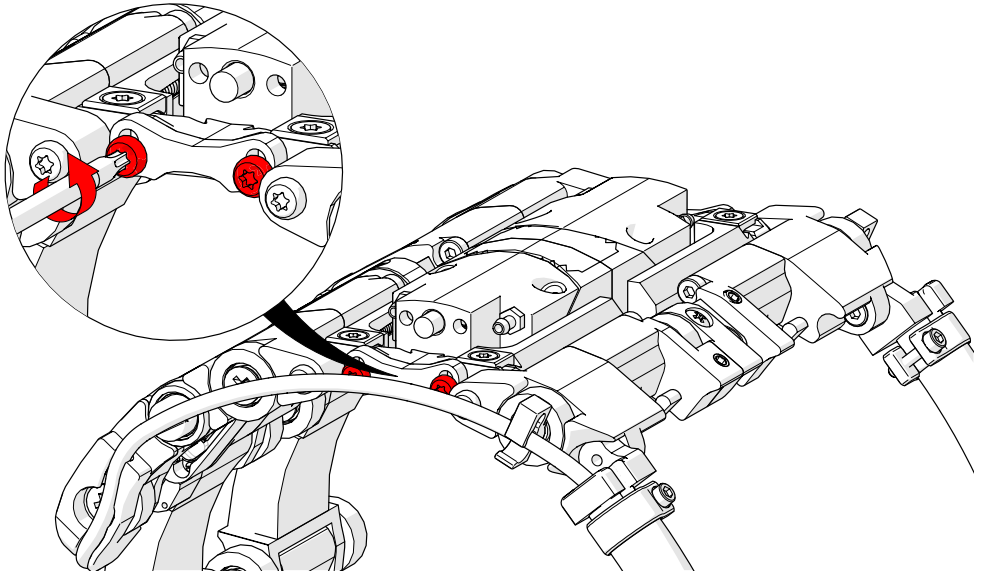

Fig. 34 - Loosen the setup tab screws

4. Loosen the two screws (Fig. 27-H) on either side of the setup tab (Fig. 27-F), do not remove these screws, a 1/4th turn should be sufficient. Perform this task on both sides of the scanner (Fig. 34).

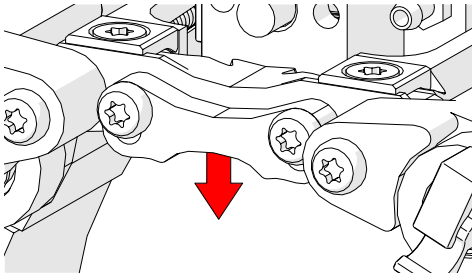

Fig. 35 - Lower setup tab

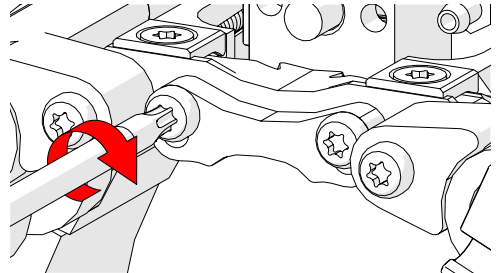

Fig. 36 - Tighten screws

5. Lower the setup tab on both sides of the scanner (Fig. 35).
6. Tighten the screws of the setup tabs (Fig. 36).

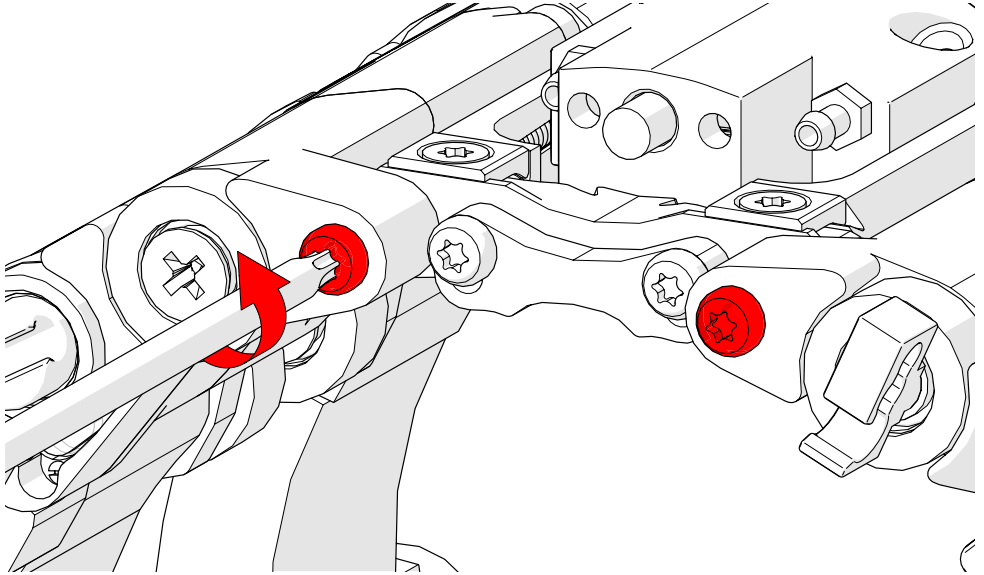

Fig. 37 - Loosen pivot adjustment screws

7. Loosen the pivot adjustment screws (Fig. 27-I) of the scanner 1/8th of a turn (Fig. 37).

NOTE: It is unnecessary to loosen pivot adjustment screws beyond a 1/8th turn. Doing so can hinder proper scanner setup.

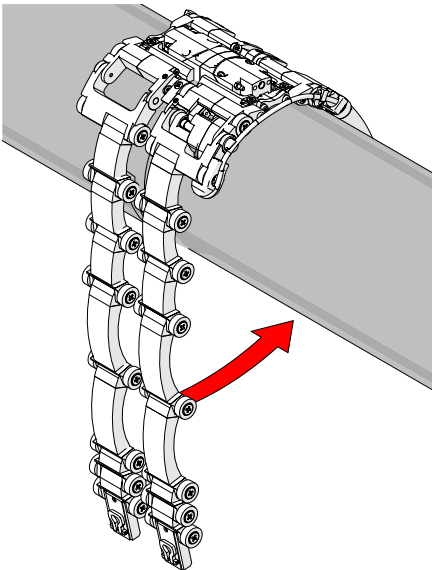

Fig. 38 - Wrap scanner around pipe/tube

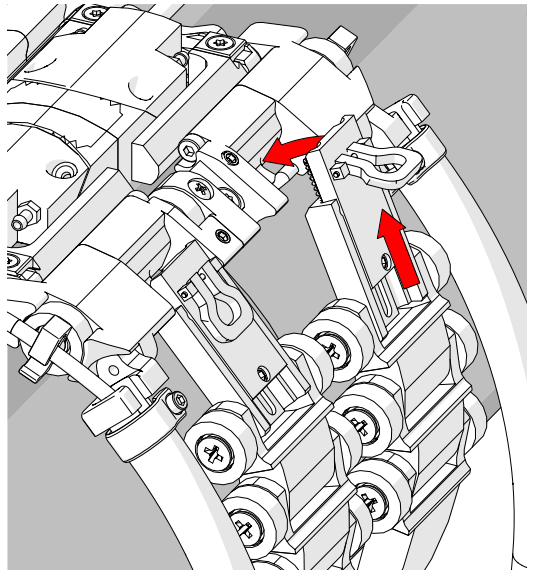

Fig. 39 - Pull and fasten latches

8. Wrap the scanner around the pipe or tube (Fig. 38).
9. Bring the scanner body around the pipe/tube. Pull and fasten latches (see *Latch Connection on page 40*) to the latch hooks (Fig. 27-K) of the scanner. (Fig. 39). Ensure the latch is in the flat position prior to scanning.

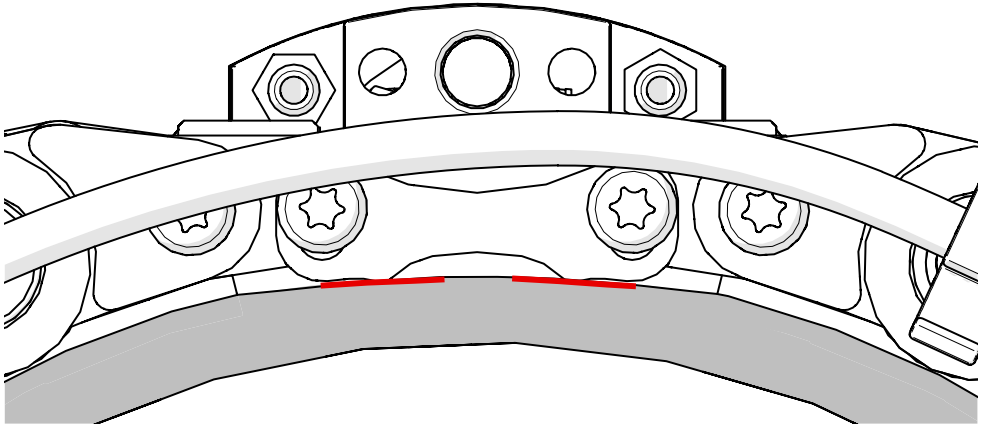

Fig. 40 - Ensure setup tab contacts scan surface

10. Ensure that all wheels and both indicator points of the setup tab are contacting the tube/pipe surface (Fig. 40).

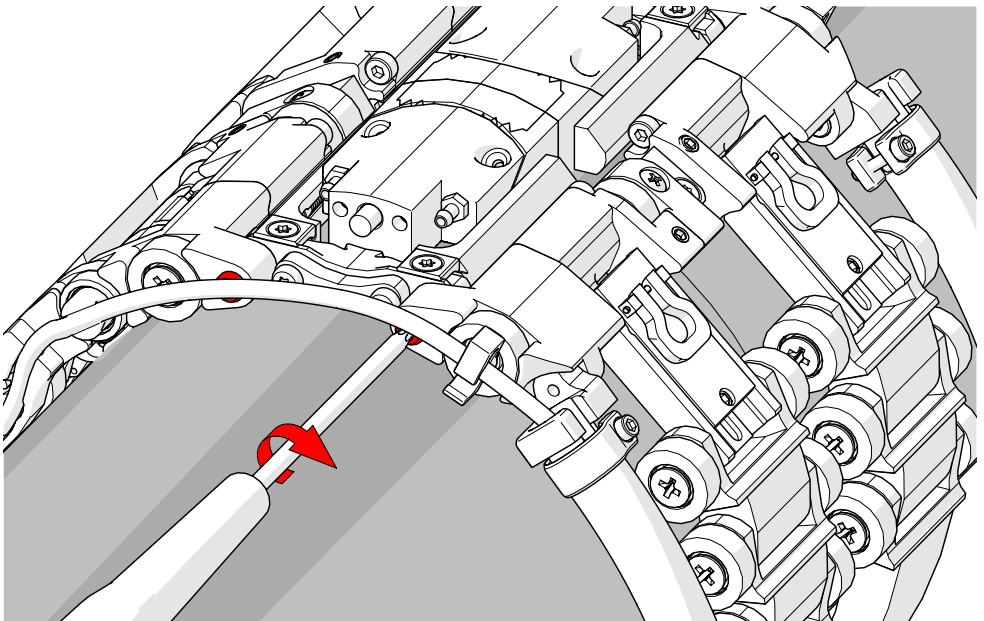

Fig. 41 - Tighten pivot adjustment screws

11. Tighten the pivot adjustment screws on both sides of the scanner (Fig. 41).

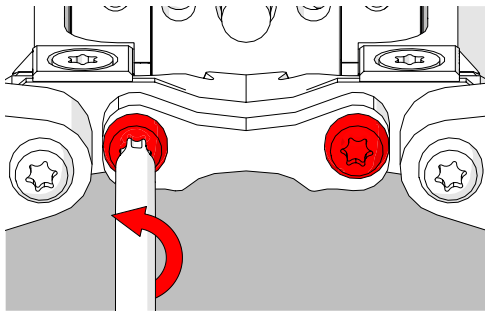

Fig. 42 - Loosen setup tab screws

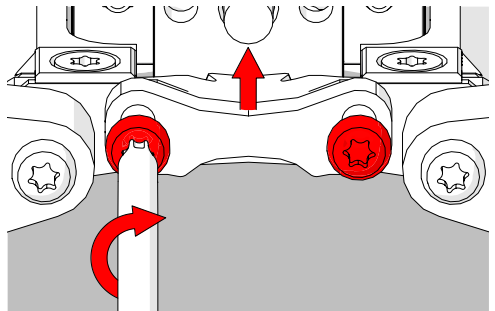

Fig. 43 - Lift setup tab and tighten screws

12. Loosen the screws of the setup tab on both sides of the scanner (Fig. 42).
13. Lift the setup tabs of the scanner and tighten the screws (Fig. 43).

7.1.1. Setup on diameters smaller than 31.75 mm (1.25 in)

Low clearance scanning on diameters smaller than 31.75 mm (1.25 in) may require removal of the encoder cable guard (Fig. 27-A).

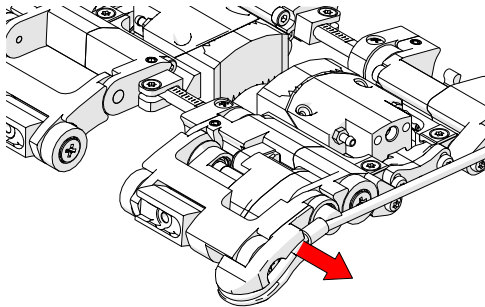

Fig. 44 - Remove encoder cable from clips

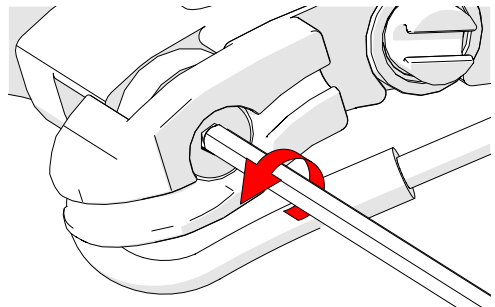

Fig. 45 - Remove screw

1. Remove the encoder cable from the clips along the side of the scanner (Fig. 44).
2. Use the supplied 2 mm hex driver (Fig. 25) to remove the screw from the wheel and encoder cable guard (Fig. 45).

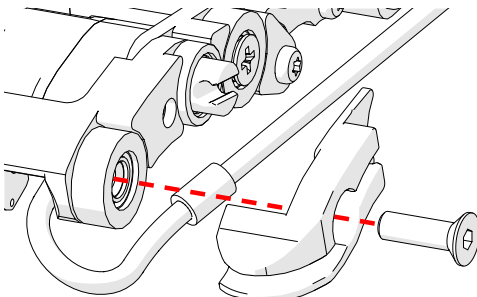

Fig. 46 - Remove encoder cable guard

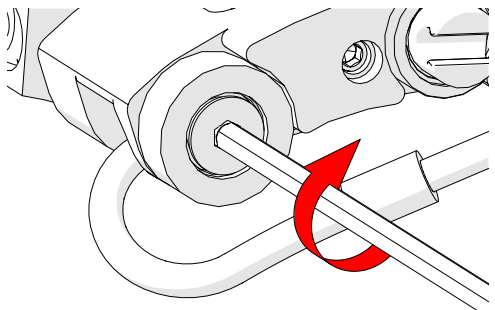

Fig. 47 - Replace screw

3. Remove the encoder cable guard (Fig. 46).
4. Replace the screw using the 2 mm hex driver (Fig. 47).
5. Place the encoder cable in the clips along the side of the scanner (Fig. 48).
6. When low clearance scanning is not required. Replace the encoder cable guard by reversing these steps.

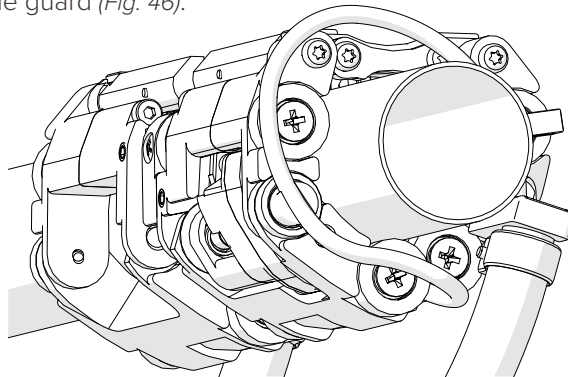

Fig. 48 - Small diameter scanning

NOTE: When scanning without the encoder cable guard, use caution to prevent pinching/wearing the encoder cable.

7.2. Single Probe Scanner Setup

To use the CIRC-IT in a single probe scanning configuration, follow these steps:

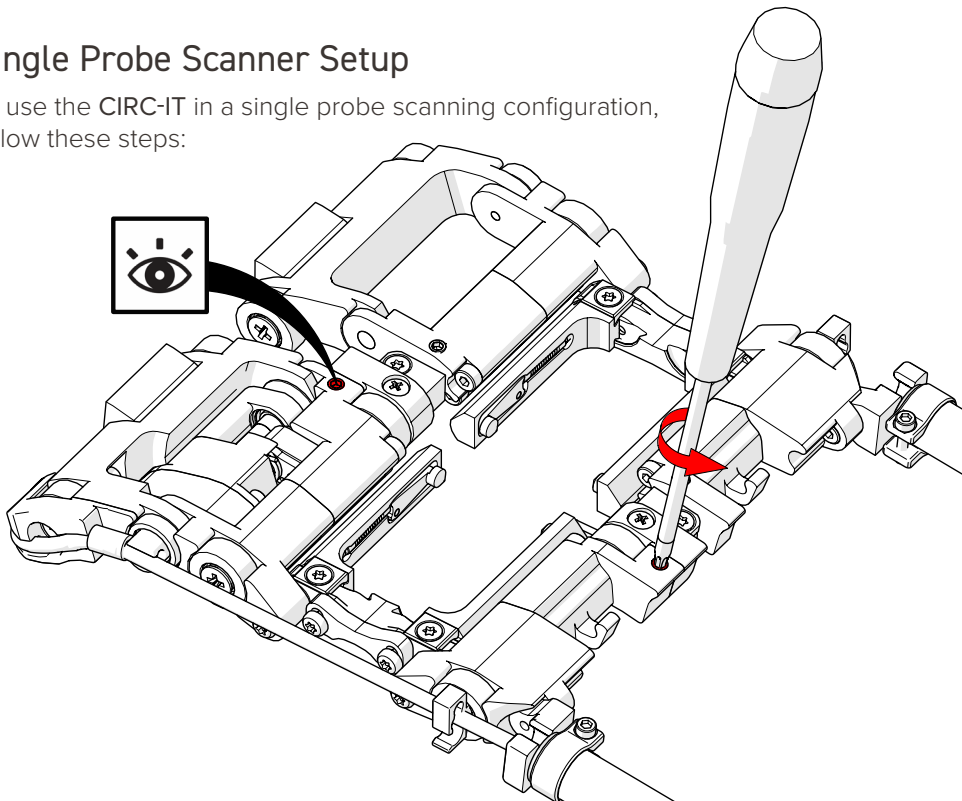

Fig. 49 - Loosen crossbar retaining screws

1. Loosen the crossbar retaining screws (Fig. 49).

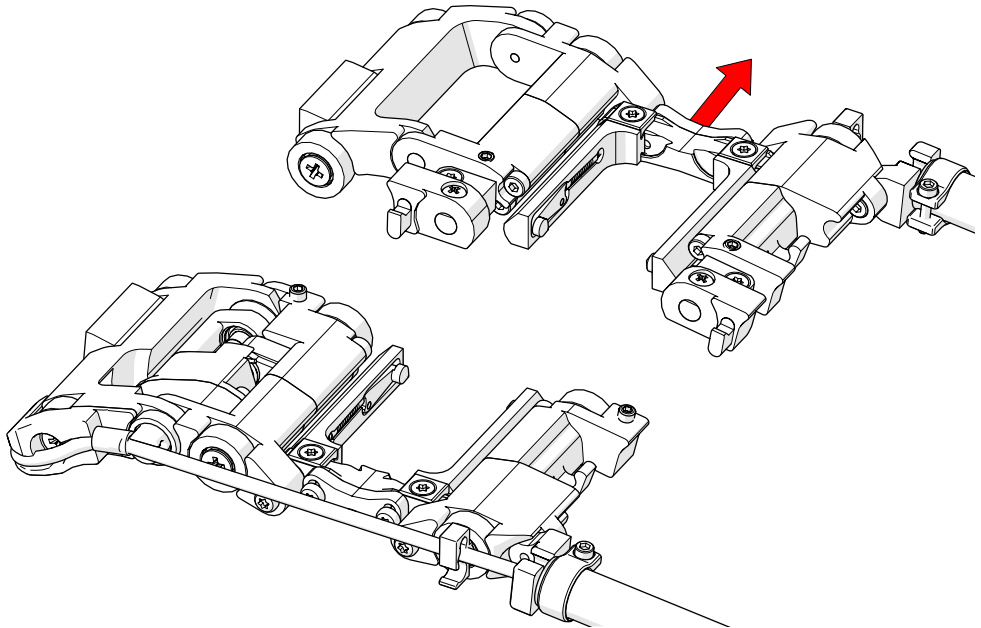

Fig. 50 - Separate scanner

2. Separate the two scanner sections (Fig. 50).

7.3. Installing Wedges

1. If present, remove chain assemblies from the scanner.

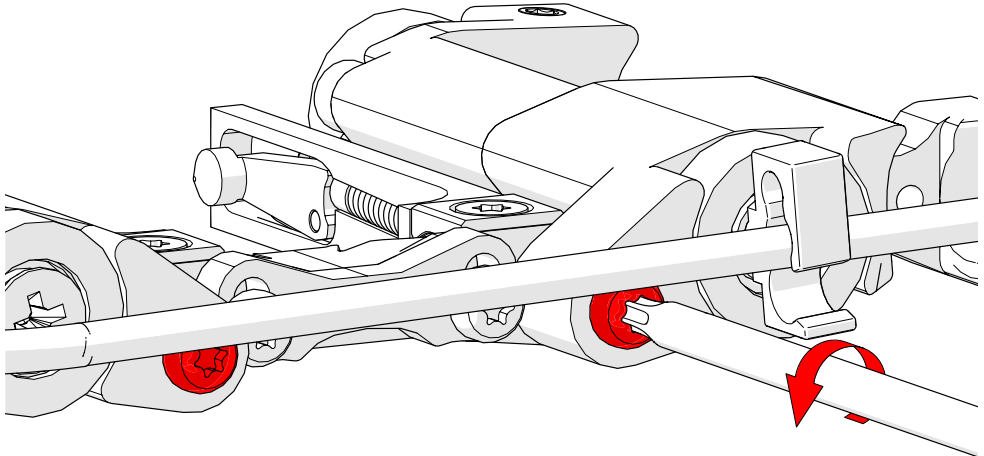

Fig. 51 - Loosen pivot adjustment screws

2. Loosen the pivot adjustment screws (Fig. 51)

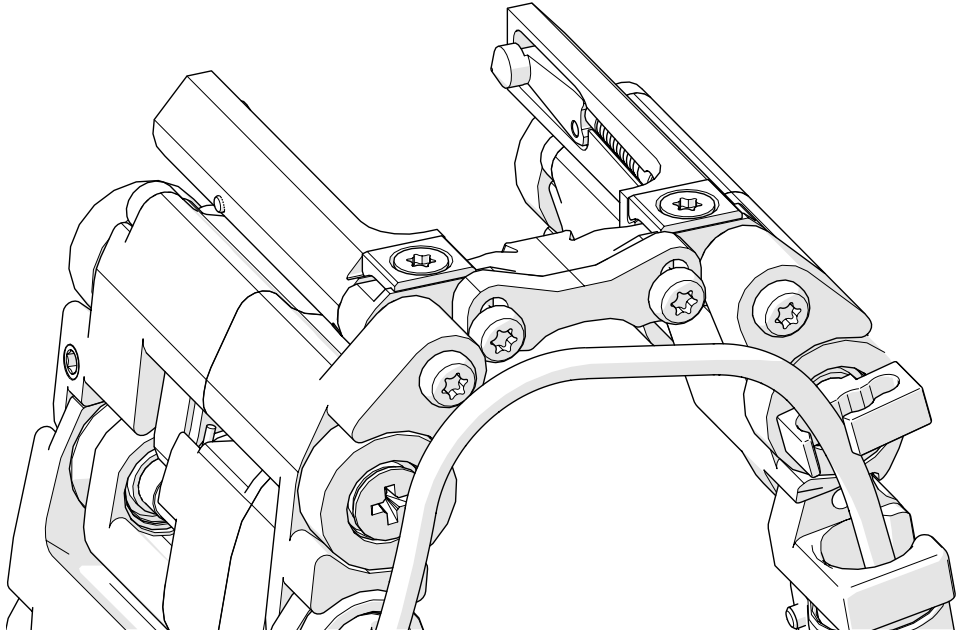

Fig. 52 - Fold scanner

3. Fold the scanner as illustrated (Fig. 52).

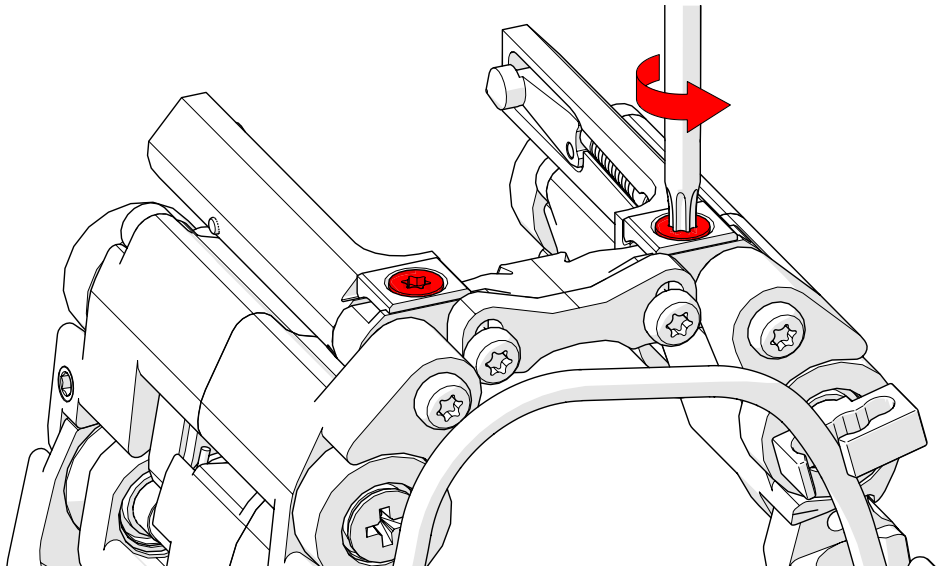

Fig. 53 - Loosen probe holder adjustment screws

4. Loosen the probe holder adjustment screws $1/8^{\text{th}}$ of a turn to relieve clamp pressure (Fig. 53).

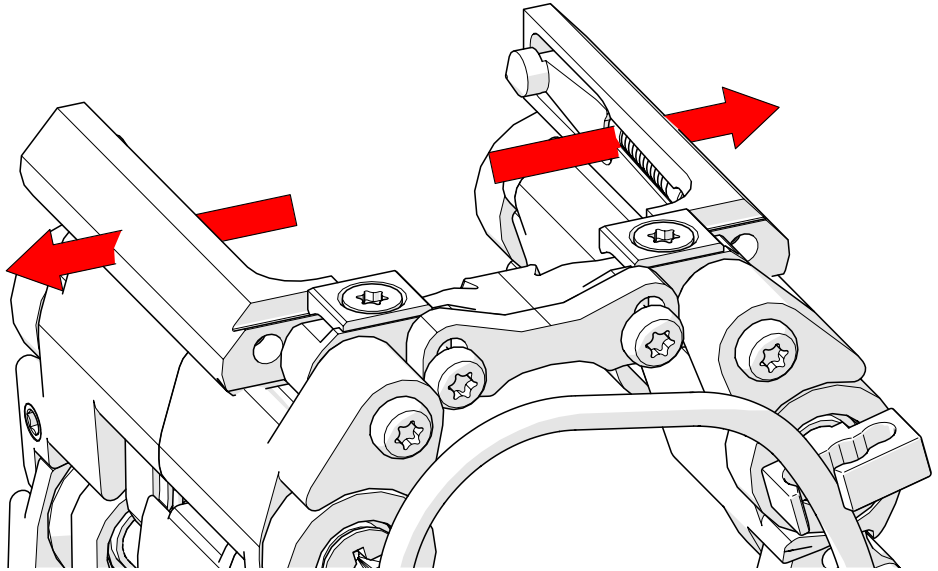

Fig. 54 - Loosen probe holder adjustment screws

5. Slide the probe holder arms out, without removing them (Fig. 54).

NOTE: It is not necessary to remove the probe holder arms. Be sure to only loosen and slide the arms outward.

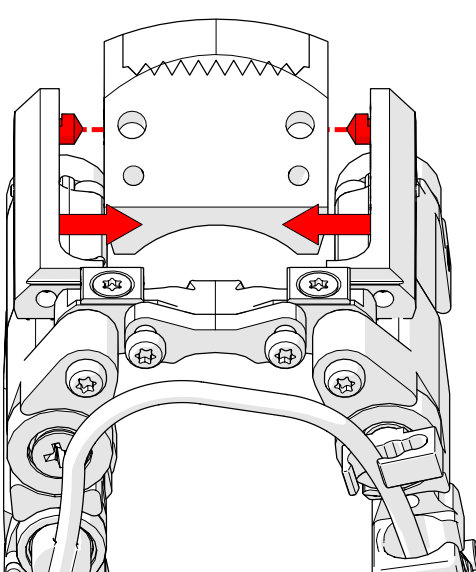

Fig. 55 - Install wedge

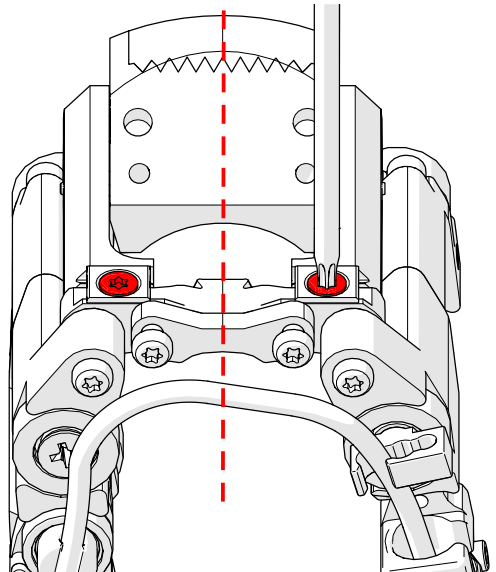

Fig. 56 - Centre wedge

6. Slide the probe holder arms around the wedge. Line up the pivot holes of the wedge with the probe holder arm pivot buttons (Fig. 55).

7. Align the wedge in the centre of the probe holder arms (Fig. 56). Tighten the probe holder adjustment screws while ensuring they arms are not pinching the wedge too tightly restricting wedge pivoting (Fig. 57).

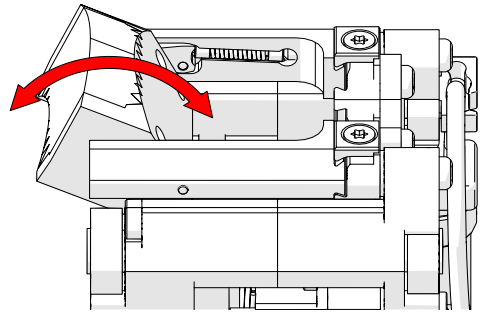

Fig. 57 - Ensure wedge pivoting

7.4. Sleeve Setup

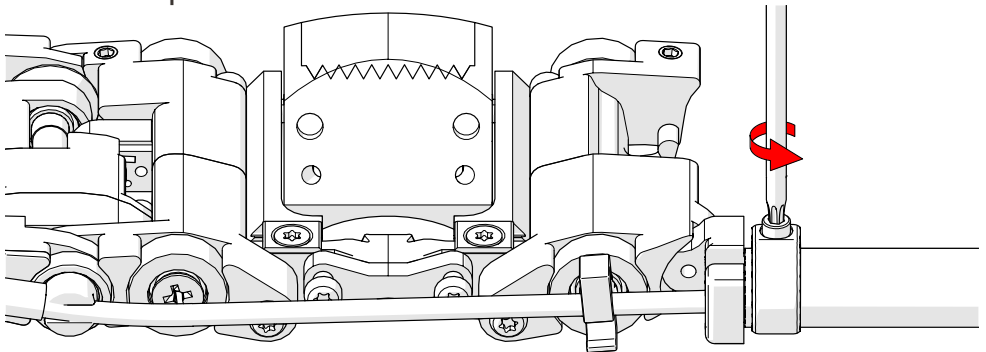

Fig. 58 - Remove sleeve clamp screw

1. Remove the sleeve clamp screw (Fig. 58) using the supplied Torx® driver (Fig. 22).

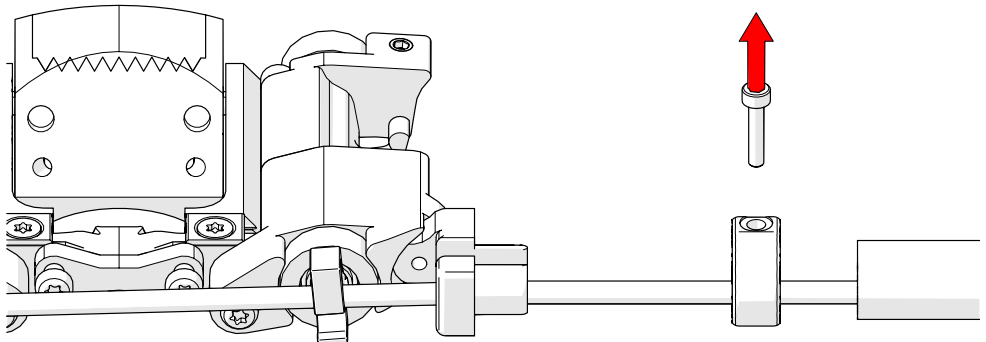

Fig. 59 - Remove sleeve, sleeve clamp and sleeve clamp screw

2. Slide the protective sleeve and the sleeve clamp from the sleeve clamp bracket (Fig. 59). Remove the sleeve and sleeve clamp from the (if applicable) encoder cable, irrigation hose and encoder cable.

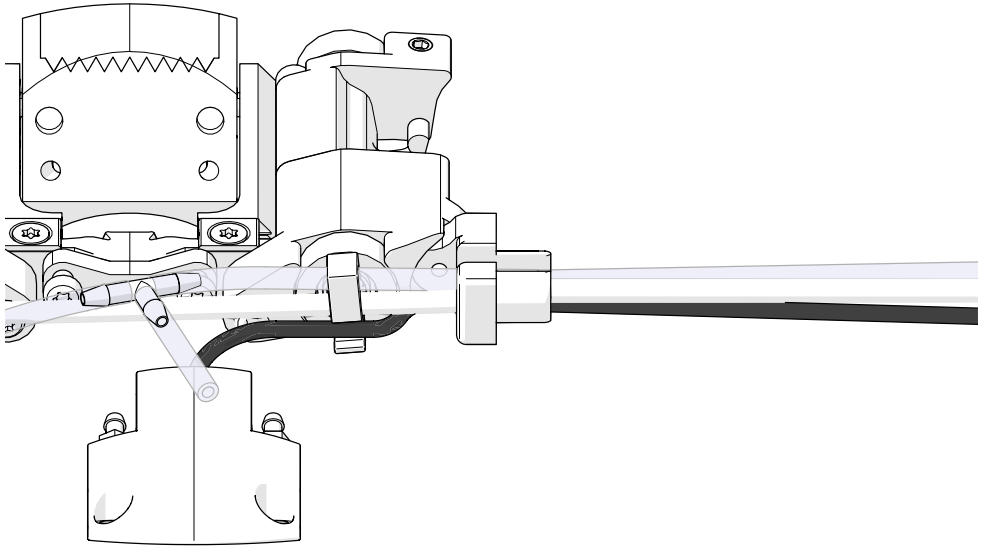

Fig. 60 - Position cables and hose

3. Place the encoder cable, irrigation hose and encoder cable in the cable management clip and run the cable/tube bundle through the sleeve clamp bracket (Fig. 60).

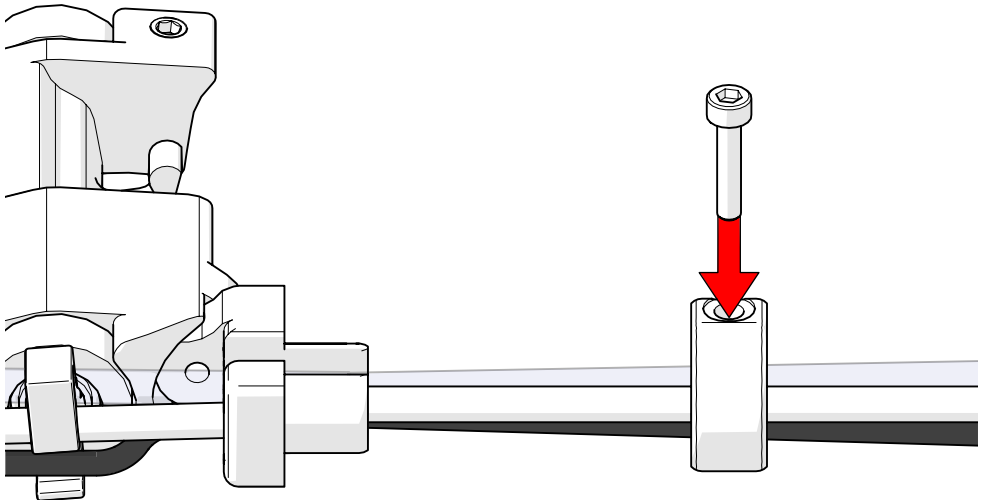

Fig. 61 - Replace sleeve clamp screw

4. Place the sleeve clamp around the cable and hoses, loosely screw in the sleeve clamp screw (Fig. 61).

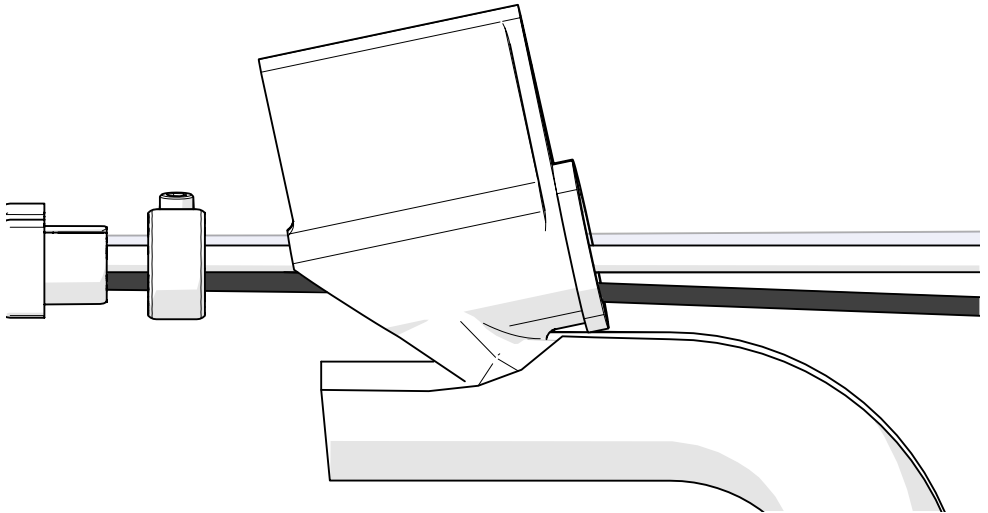

Fig. 62 - Loom installation tool

5. Use the loom installation tool to install the protective sleeving over the cable/tube bundle (*Fig. 62*).
6. Begin at the scanner end, wrap the tool around the cables with the shoe pointing away from the scanner. Use the shoe of the loom to open the sleeving and begin wrapping the open sleeve around the cables (*Fig. 62*).

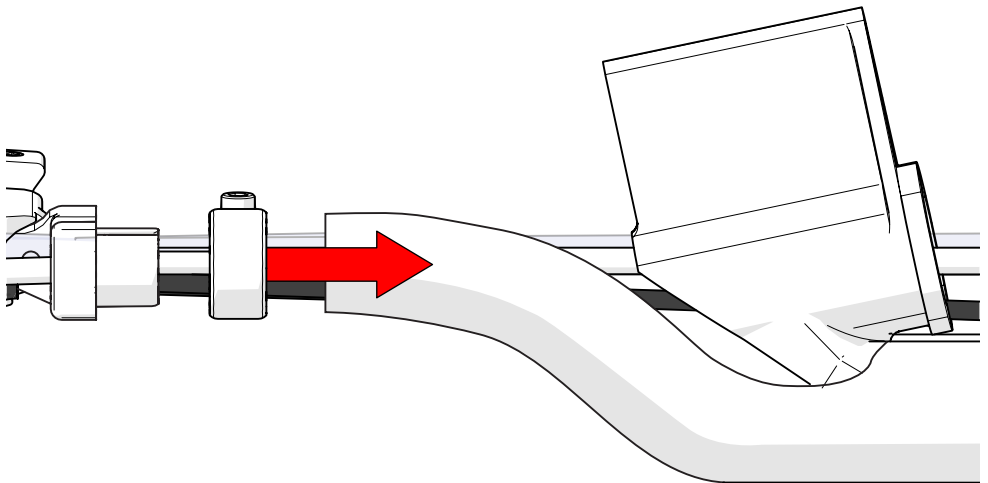

Fig. 63 - Slide the sleeve clamp around sleeving

7. Once an amount of the sleeving has been installed around the cables, slide the sleeve clamp around the sleeving (*Fig. 63*).

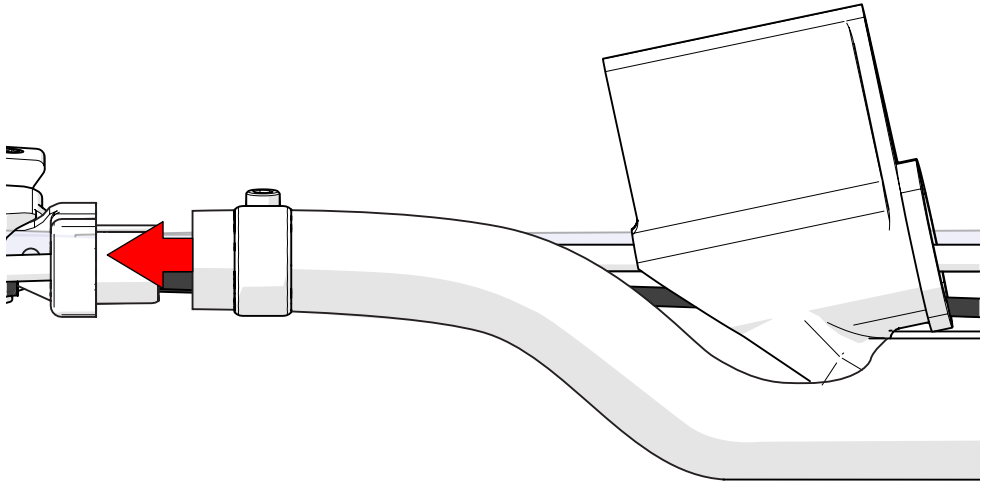

Fig. 64 - Position around sleeve clamp bracket

8. Bring the sleeving around the sleeve clamp bracket (*Fig. 64*).

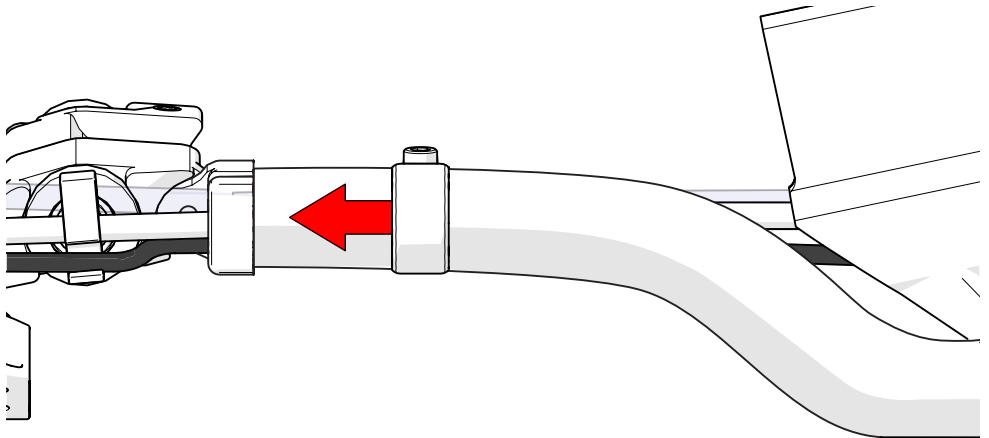

Fig. 65 - Place sleeve clamp around sleeving and sleeve clamp bracket

9. Slide the sleeve clamp over the sleeve clamp bracket and the protective sleeve (*Fig. 65*).

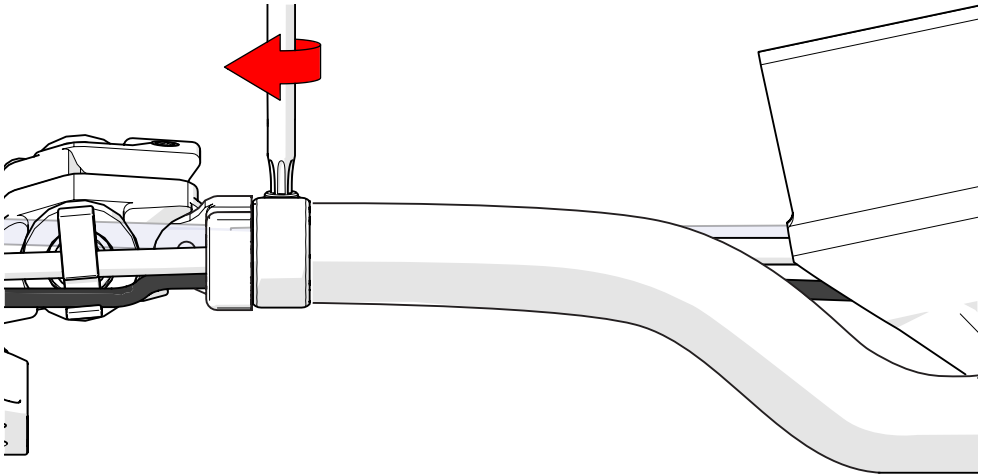

Fig. 66 - Tighten sleeve clamp screw

10. Tighten the sleeve clamp screw pinching the sleeve in place with the sleeve clamp bracket (Fig. 66).

TIP: Ensure the sleeve clamp is oriented correctly (Fig. 68) and the sleeve clamp screw will not protrude lower than the scanner wheels (Fig. 67).

NOTE: Do not over tighten the sleeve clamp screw as this may cause the screw to break.

11. Continue inserting the remaining cable and hoses into the protective sleeve using the loom installation tool.
12. Repeat this sleeving process with scanners opposite side.

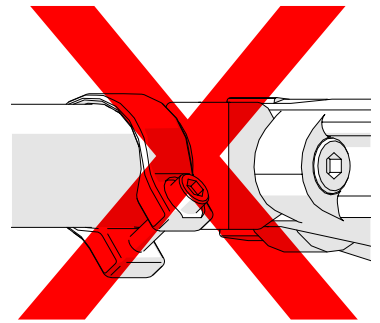

Fig. 67 - Incorrect clamp alignment

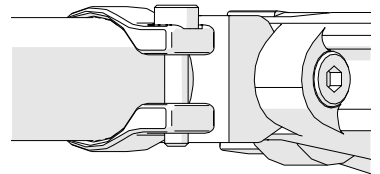

Fig. 68 - Correct clamp alignment

7.5. Setting Wedge Spacing

1. If present, remove all chain assemblies from the scanner.
2. Ensure wedges are installed (see *Installing Wedges on page 20*).

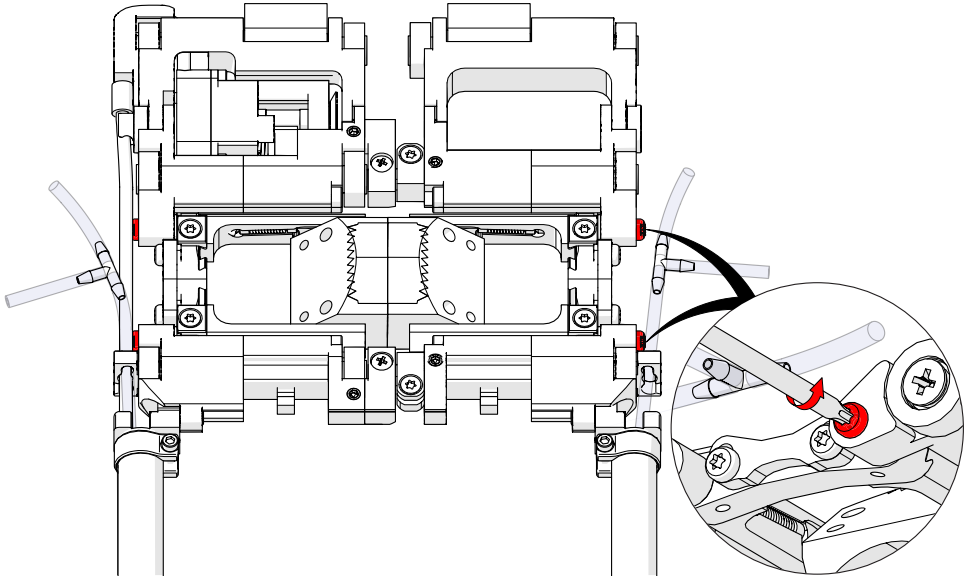

Fig. 69 - Loosen the pivot adjustment screws

3. Use the supplied Torx® driver (Fig. 22), loosen the four pivot adjustment screws (Fig. 69) and press the scanner against a flat surface straightening out the scanner.

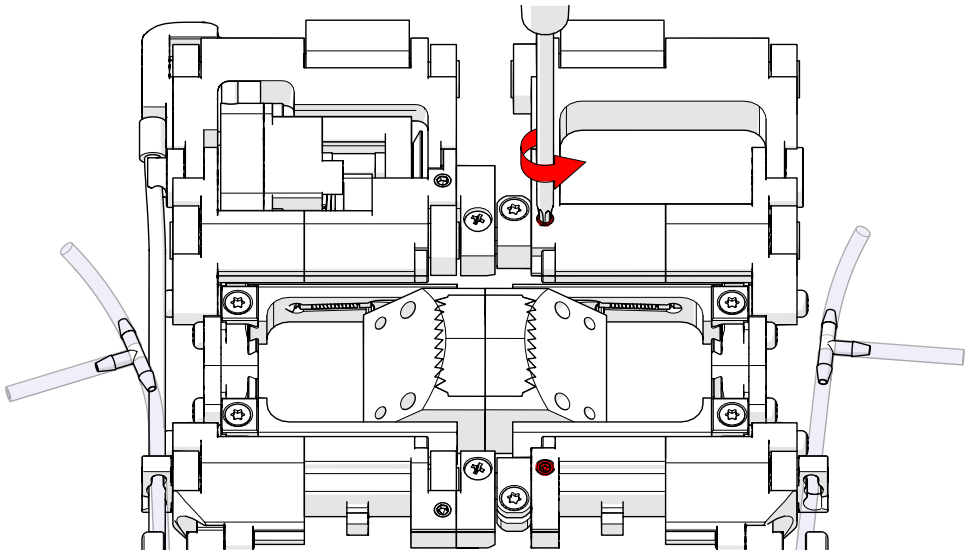

Fig. 70 - Loosen the crossbar clamp screws

4. Loosen the two crossbar clamp screws located on the dual side of the scanner (Fig. 70).

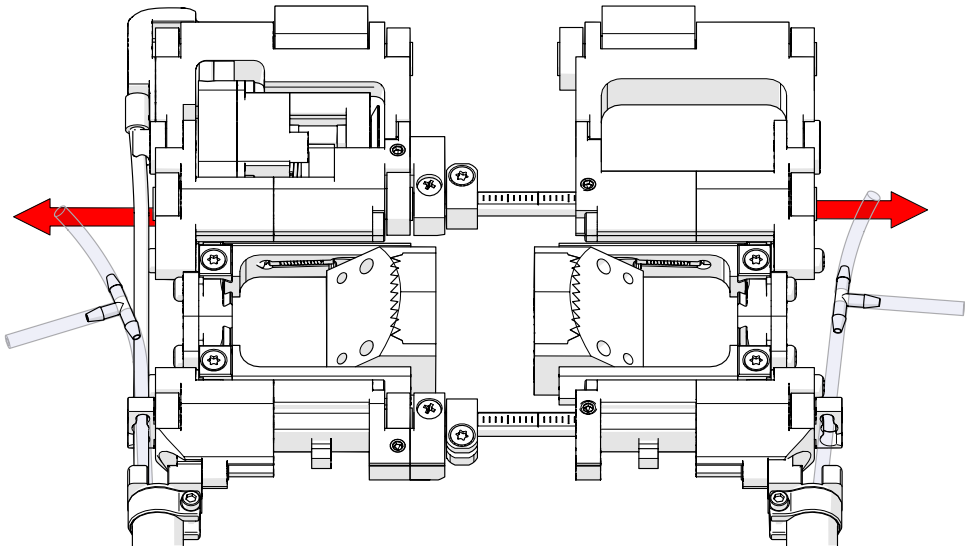

Fig. 71 - Slide apart to required spacing

5. Slide the two sides of the scanner apart, use the measurements of the crossbar to determine desired spacing (Fig. 71).

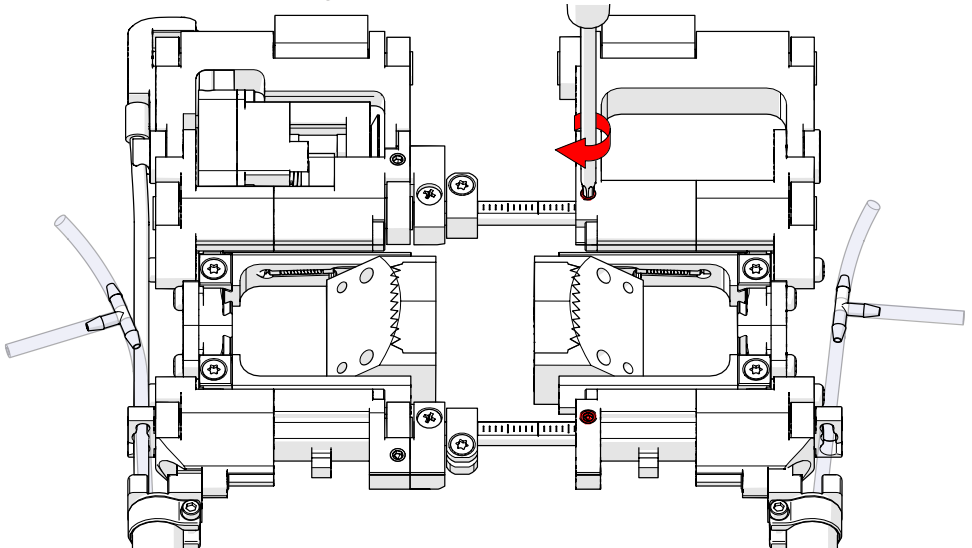

Fig. 72 - Tighten crossbar clamp screws

6. Ensure alignment of the scanner using the measurements on the crossbar and tighten the crossbar clamp screws (Fig. 72).

7.5.1. Wedge Separation Indicators

The wedge separation indicators allow precise probe/wedge spacing. The crossbar graduations indicate millimeter measurement. To utilize the wedge separation indicators, follow these steps:

1. If present, remove all chain assemblies from the scanner.
2. Ensure wedges are installed (see *Installing Wedges* on page 20).
3. Use the supplied Torx® driver (Fig. 22) to loosen the four pivot adjustment screws (Fig. 69), press the scanner against a flat surface to straighten.

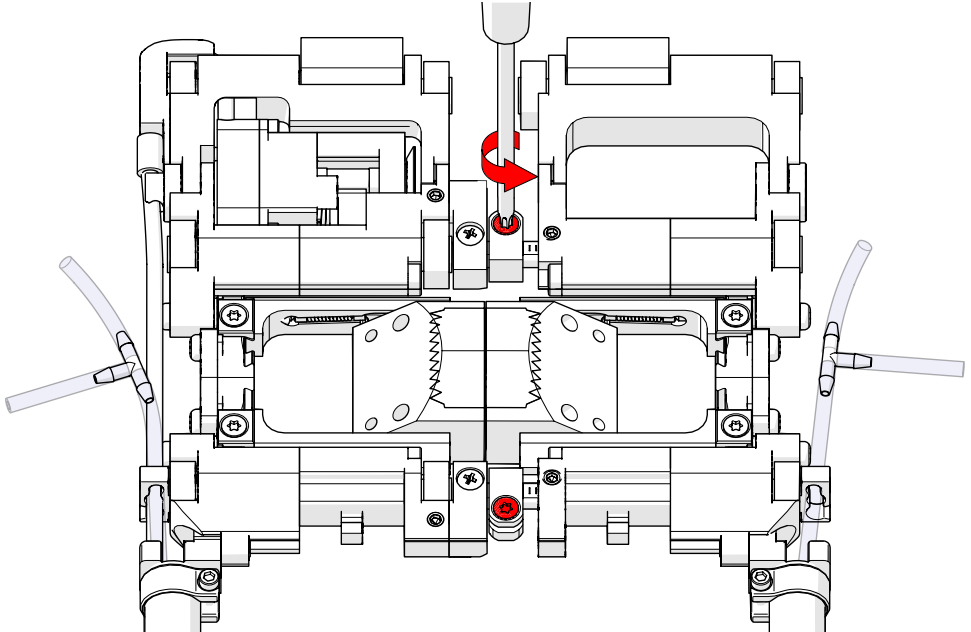

Fig. 73 - Loosen the pivot adjustment screws

4. Use the supplied Torx® driver to loosen the both wedge separation indicator clamp screws (Fig. 73).

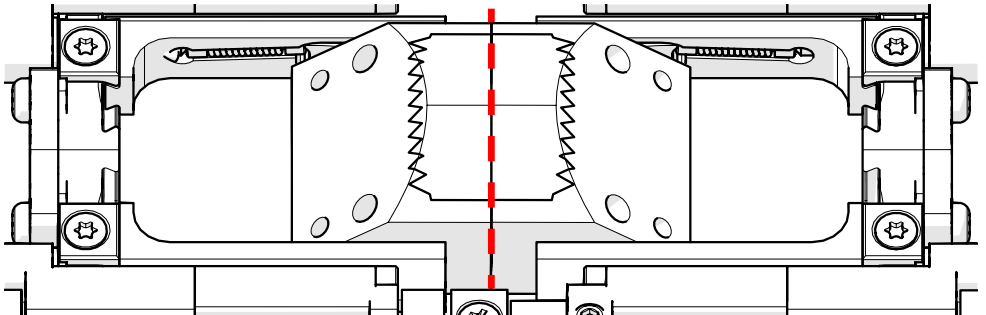

Fig. 74 - Ensure wedge contact

5. Slide the scanner together until the wedges make contact (Fig. 74).

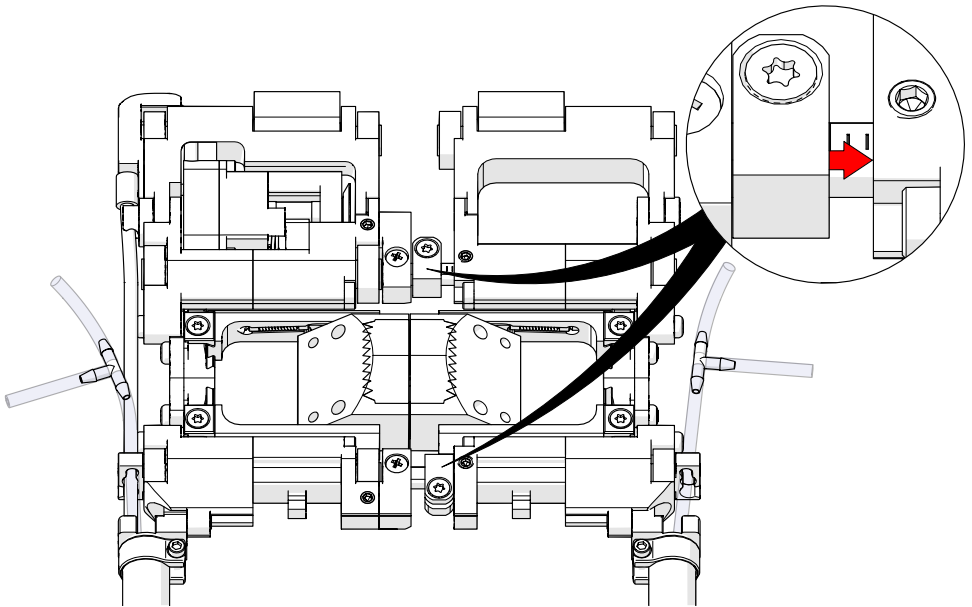

Fig. 75 - Position wedge separation indicators

6. Ensure the wedges continue to touch while sliding the wedge separation indicators to contact the dual side of the scanner (Fig. 75).

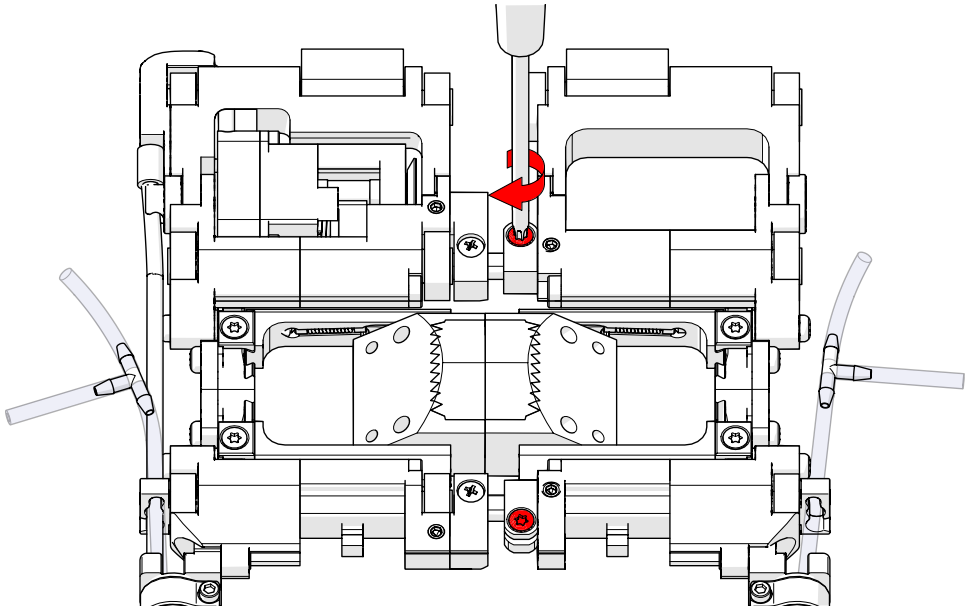

Fig. 76 - Tighten wedge separation indicator clamp screws

7. Tighten the wedge separation indicator clamp screws (Fig. 76).

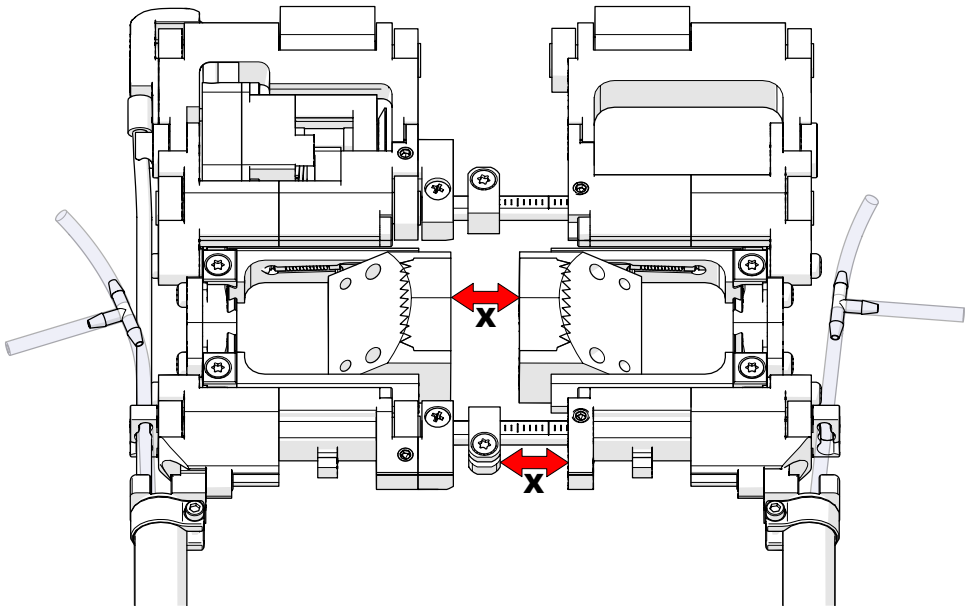

Fig. 77 - Set precise wedge separation

8. Slide the two sides apart until desired wedge separation is achieved (Fig. 77). Use the graduations on the crossbar for precise positioning. The graduations indicate millimeter measurement.

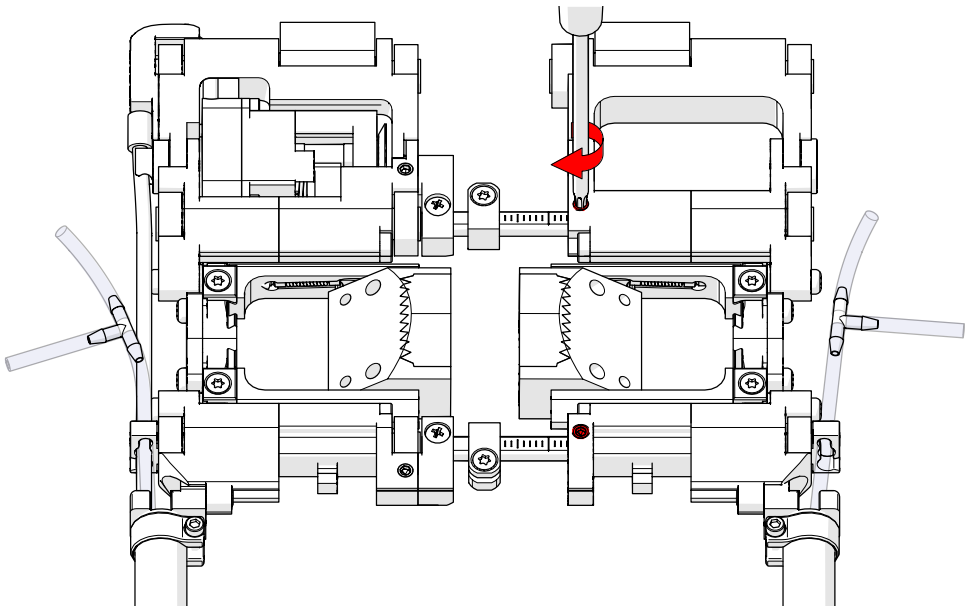

Fig. 78 - Tighten crossbar clamp screws

9. Tighten both crossbar clamp screws (Fig. 78).

7.6. Switching Crossbars

Additional crossbars of various lengths are included with the CIRC-IT and sold separately. These alternate crossbar lengths allow for increased probe spacing when required (see *Dimensions and Weight on page 3*).

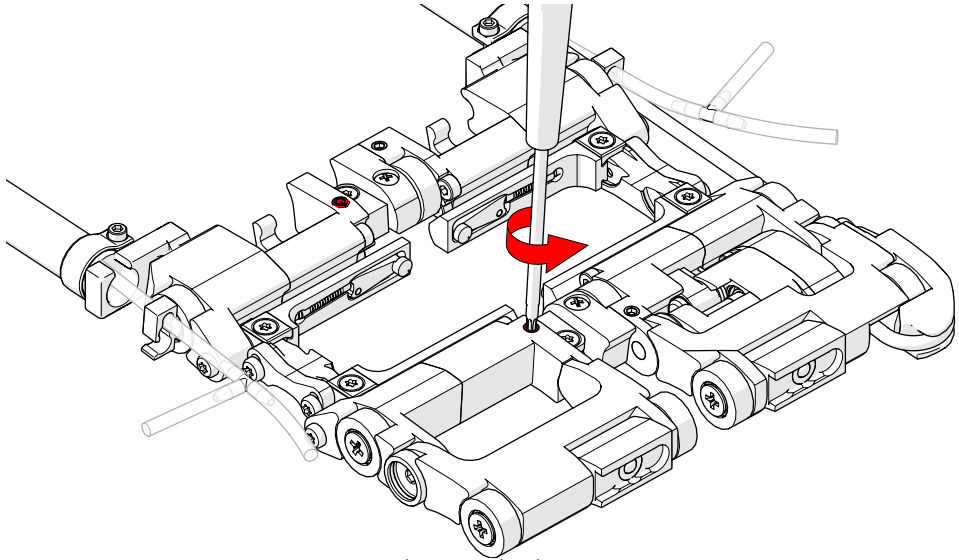

Fig. 79 - Loosen crossbar clamp screws

1. Use the Torx® driver (Fig. 22) to loosen the two crossbar clamp screws (Fig. 79).

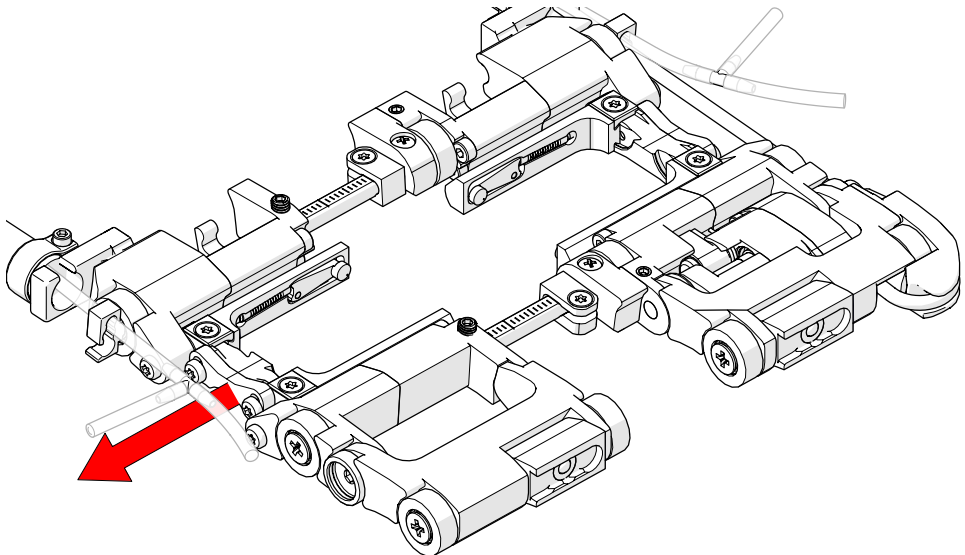

Fig. 80 - Separate the scanner sides

2. Gently pull the scanner apart, separating the dual and single sides (Fig. 80).

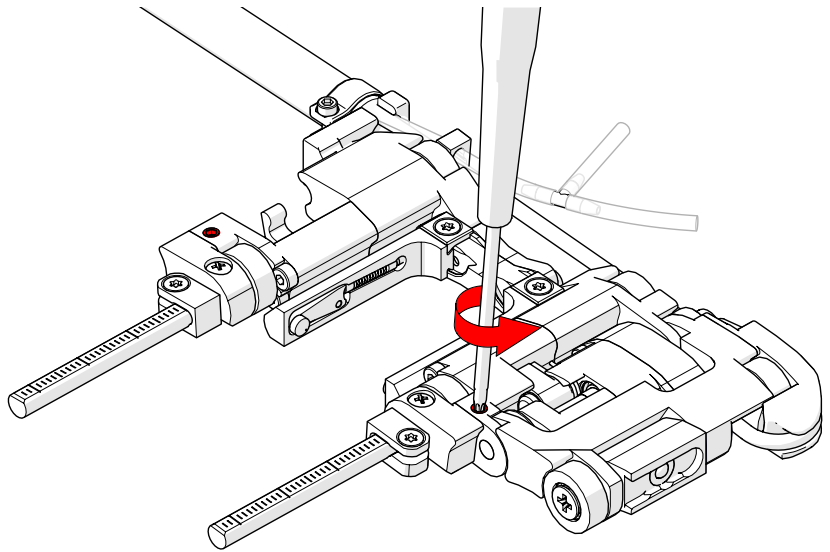

Fig. 81 - Loosen crossbar retaining screws

3. Use the Torx® driver to adequately loosen the crossbar retaining screws (Fig. 81).

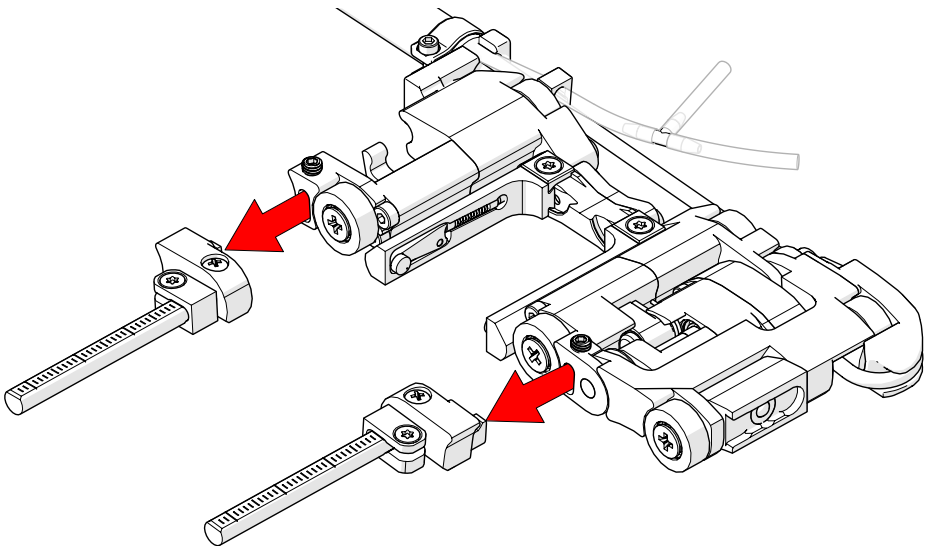

Fig. 82 - Remove crossbar assemblies

4. Remove the crossbar assemblies from the scanner single side (Fig. 82).

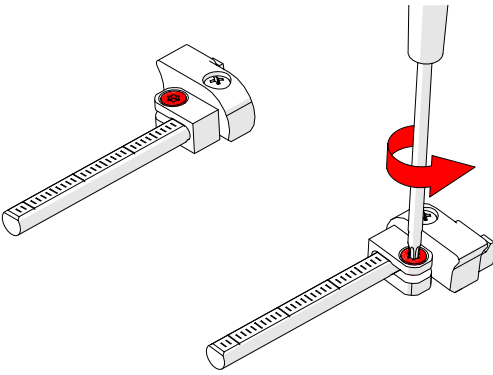

Fig. 83 - Loosen the wedge separation indicator clamp screw

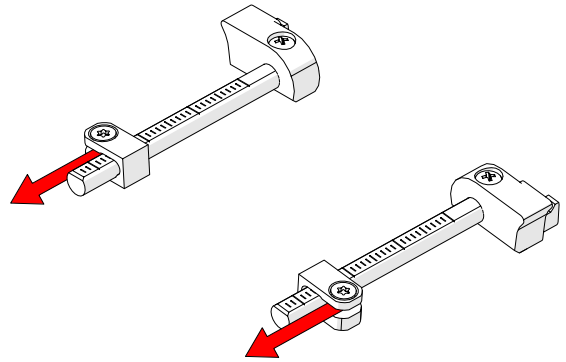

Fig. 84 - Remove the wedge separation indicator

5. Use the Torx® driver to loosen the wedge separation indicator clamp screw (Fig. 83).
6. Slide the wedge separation indicator off the crossbar (Fig. 84).

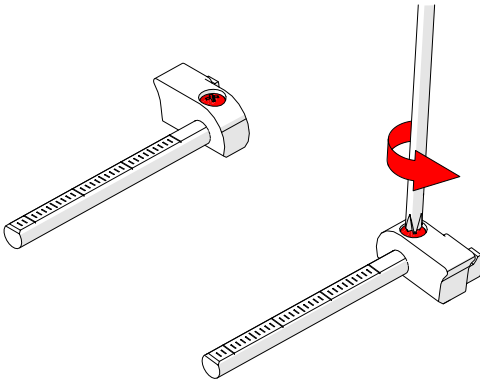

Fig. 85 - Remove the crossbar clamp bracket screw

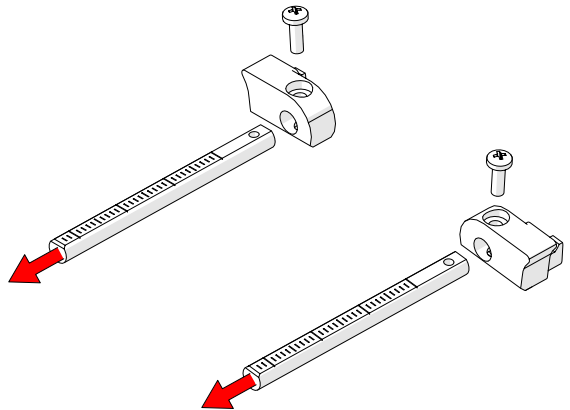

Fig. 86 - Remove crossbars from crossbar clamp bracket

7. Using the Phillips driver (Fig. 23), unscrew the crossbar clamp bracket screws (Fig. 85).
8. When the crossbar clamp bracket screws are removed, slide the crossbars from the crossbar clamp bracket (Fig. 86).
9. Select the length of crossbar required for appropriate probe spacing and reverse the preceding steps (Fig. 87).

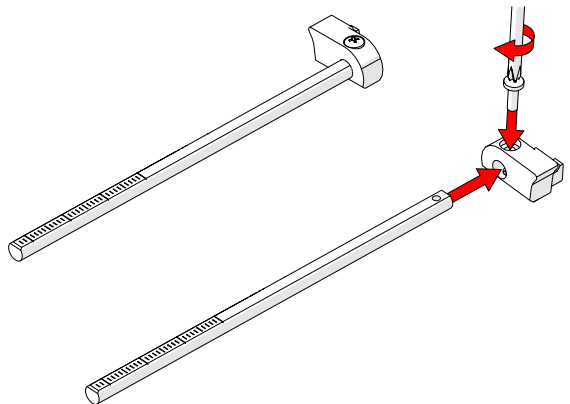

Fig. 87 - Reverse steps using required crossbars

7.7. CIRC-IT Setup (Single-Sided Access)

To configure the CIRC-IT for applications when access to the pipe/tube is single-sided, use the supplied chain retrieval tool (Fig. 24) and follow these steps:

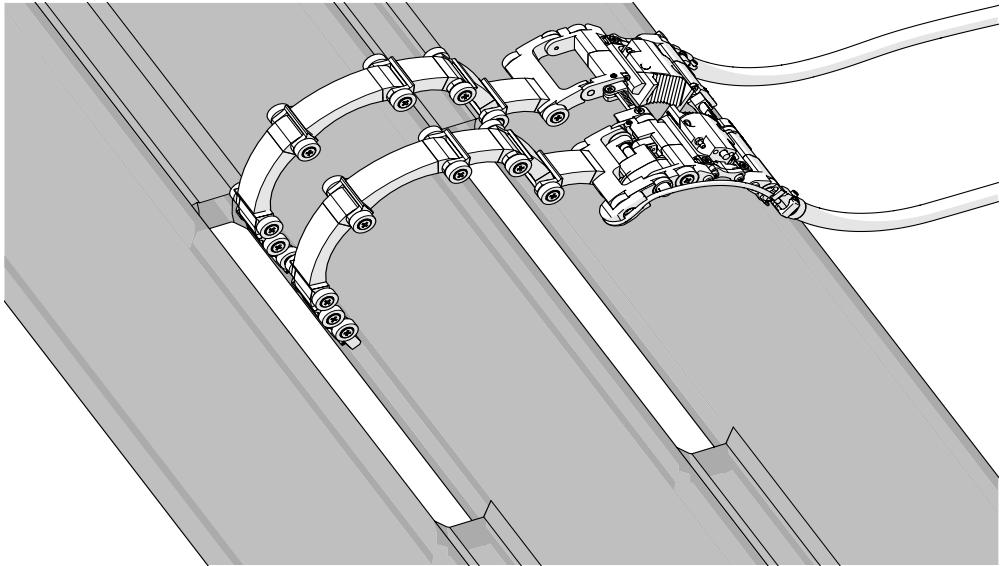

Fig. 88 - Position links as illustrated

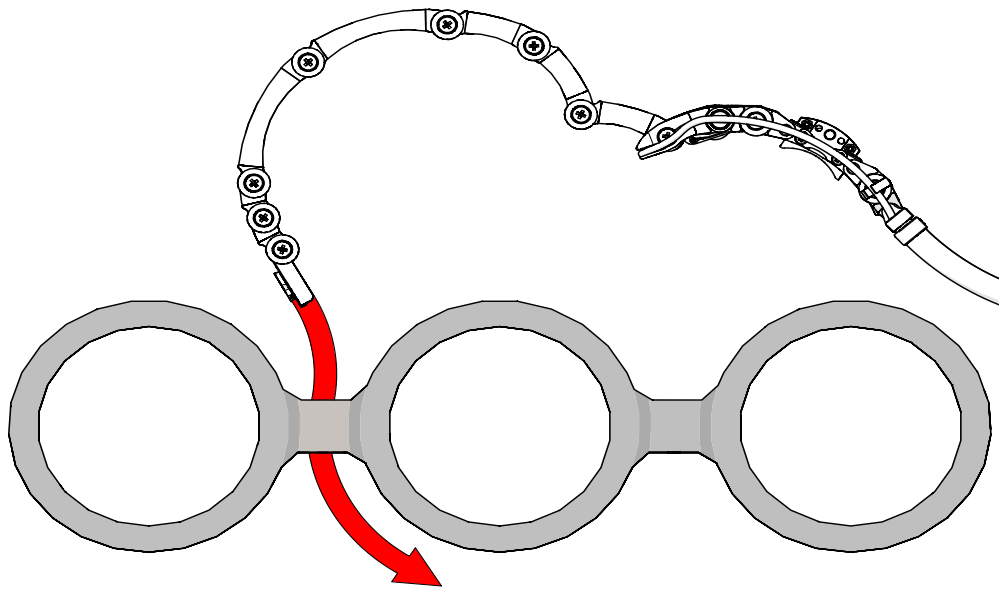

Fig. 89 - Position links as illustrated

1. Shape the links and wheels to a slight curve not including the scanner body (Fig. 88) and (Fig. 89).

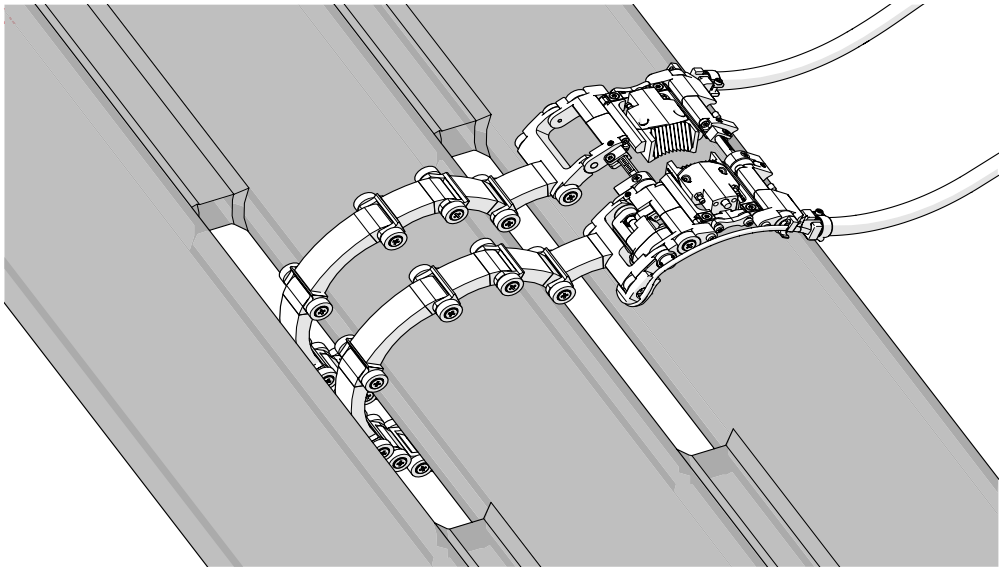

Fig. 90 - Pivot scanner while rotating links around pipe/tube

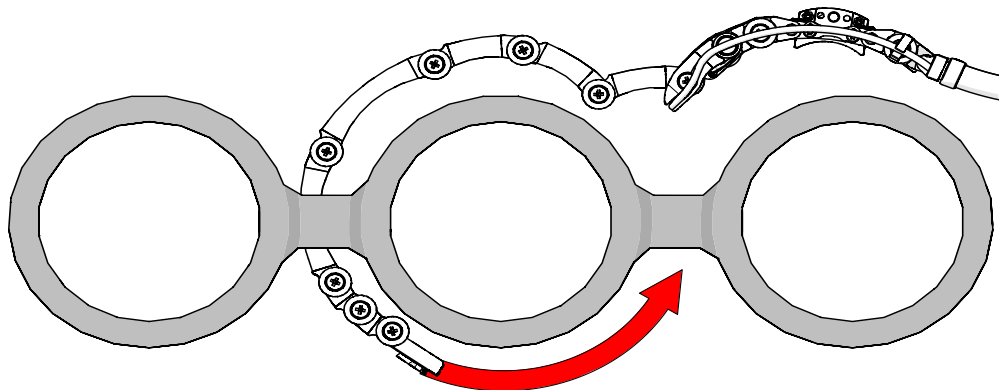

Fig. 91 - Pivot scanner while rotating links around pipe/tube

3. While guiding the links around the pipe/tube, pivot the scanner body as required (Fig. 90) and (Fig. 91).

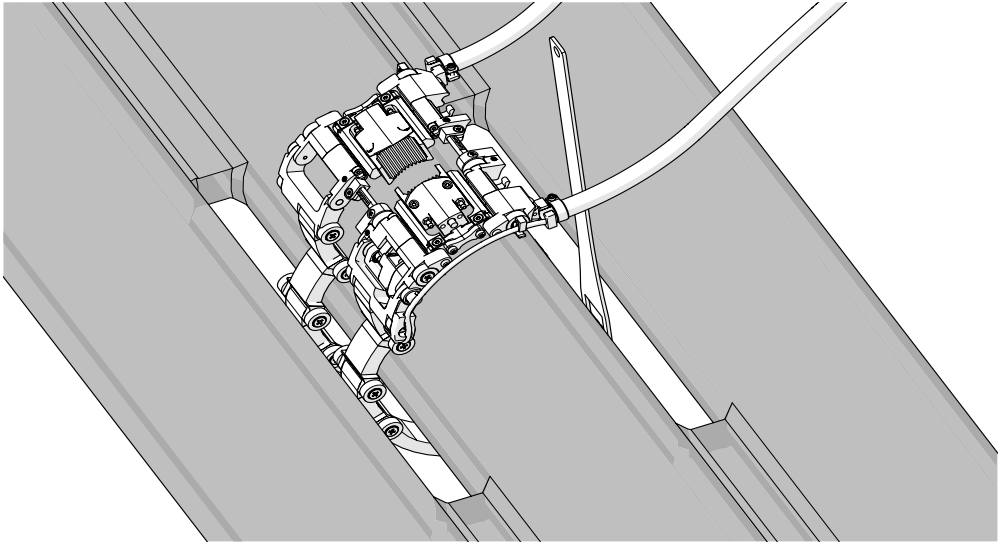

Fig. 92 - Use chain retrieval tool to access latch

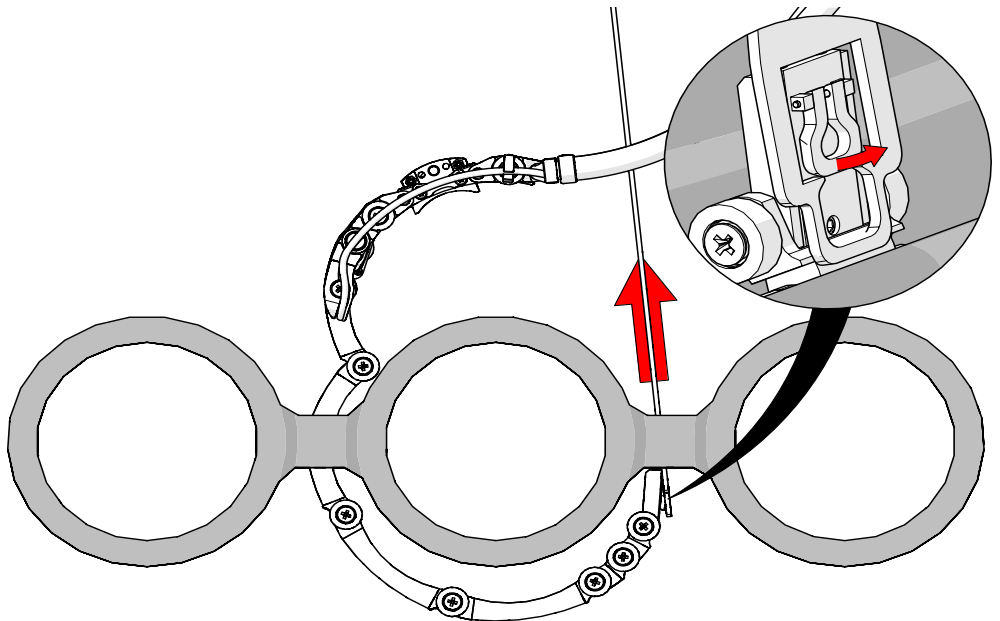

Fig. 93 - Use chain retrieval tool to access latch

4. The chain retrieval tool is used to pull the latch through a tight space. The chain retrieval tool is designed to flip open the latch's tab, allowing the chain retrieval tool to hook the latch tab (*Fig. 92*) and (*Fig. 93*). The chain retrieval tool can also be used if available space to retrieve the latch is too small and the tab can not be opened.

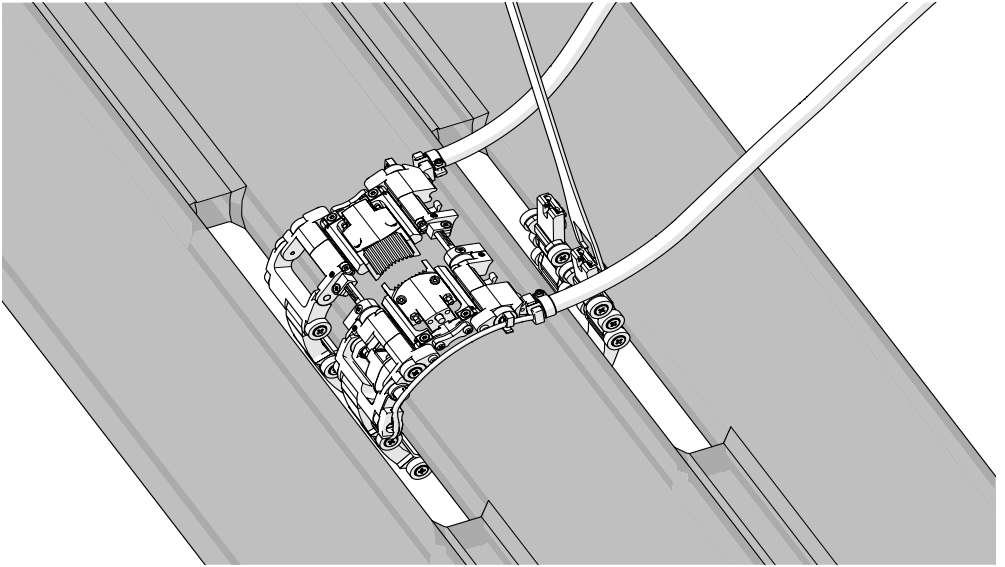

Fig. 94 - Bring latch towards the latch hook

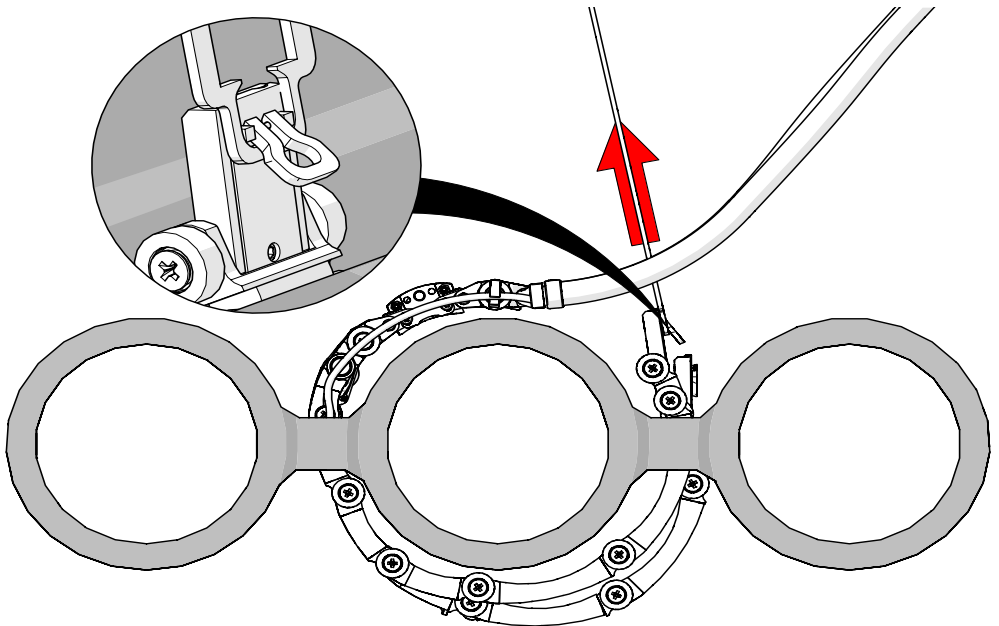

Fig. 95 - Bring latch towards the latch hook

5. Bring the latch around the scan surface (*Fig. 94*) and (*Fig. 95*).

6. To complete the installation of the scanner, pull the latch over the latch hook of the scanner. Bring the latch down and hook the scanner's latch hook. (see *Latch Connection* on page 40).

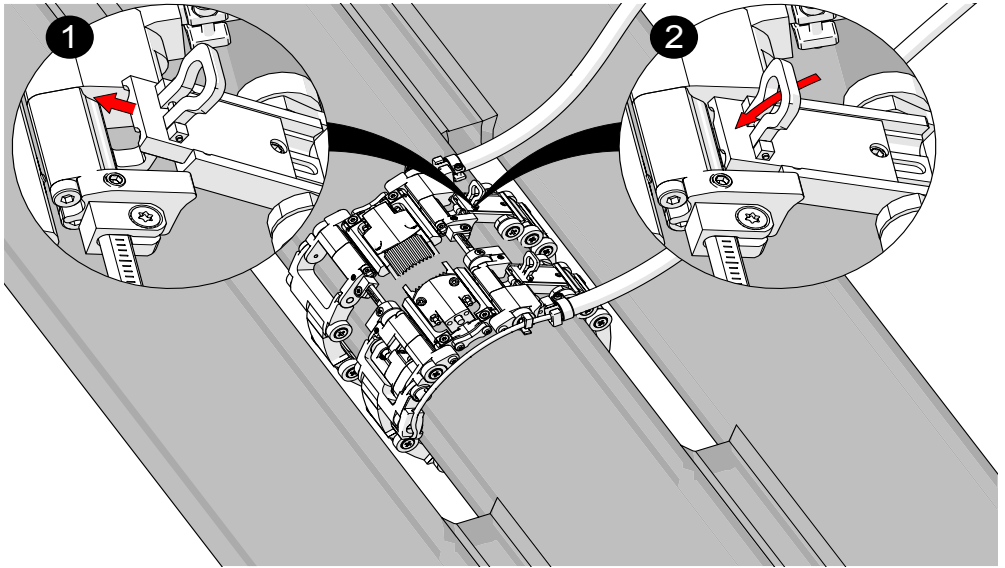

Fig. 96 - Tighten wedge separation indicator clamp screws

7.8. Latch Connection

The short and long latch are the final connection point of the scanner. Either of these latches may be used depending on the size of the pipe or tube to be scanned (see *CIRC-IT Setup Chart* on page 54). To achieve optimal performance, use the latch connection that offers the tightest fit.

TIP: This example displays a long latch.

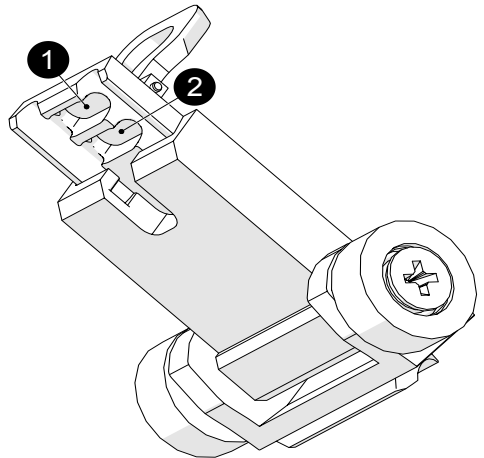

Fig. 97 - Two latching points

7.9. Link Connection

A variety of links are included with the CIRC-IT. To connect the links, see the following steps:

TIP: These connection instructions also apply to wheel links and latches.

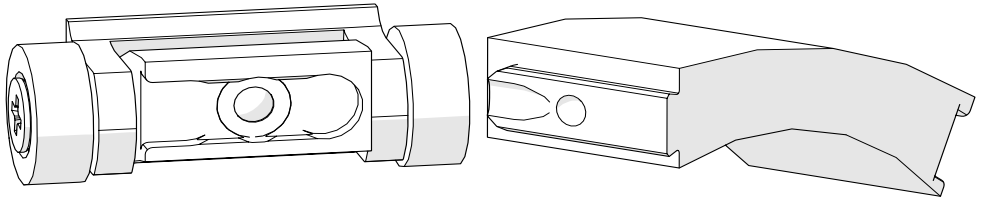

Fig. 98 - Link ends differ

1. Note the different ends of the links which will provide the connection (Fig. 98).

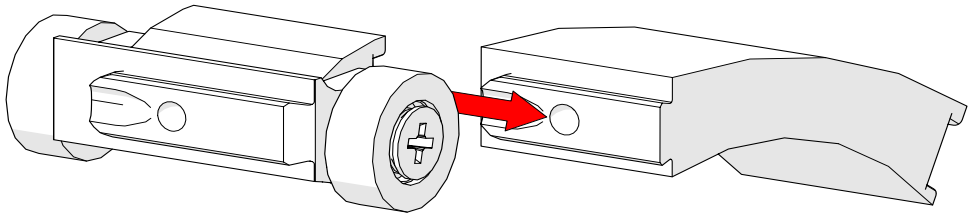

Fig. 99 - Slide links together

2. Align the two links horizontally and slide them together (Fig. 99).

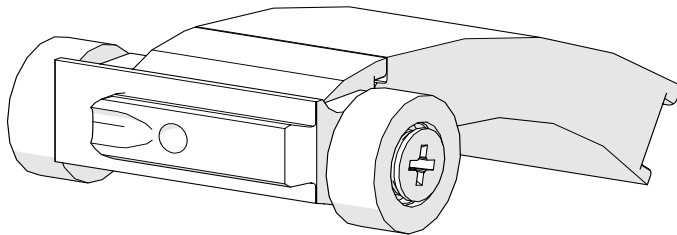

Fig. 100 - Connected link and wheel link

3. When the links are flush and you feel/hear the spring plunger click, the links are properly connected (Fig. 100).
4. To disconnect links and wheel links, reverse these steps.

NOTE: Alternate wheel links and links ensuring links are always separated by a wheel link (see Correct Link Configuration on page 42).

7.9.1. Correct Link Configuration

Proper link configuration and setup is necessary to achieve optimal scanner performance. Ensure the following points are implemented:

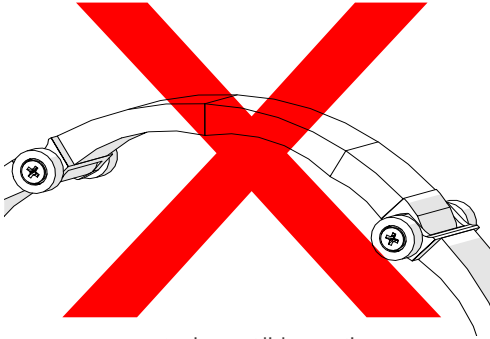

Fig. 101 - Incorrect link connection

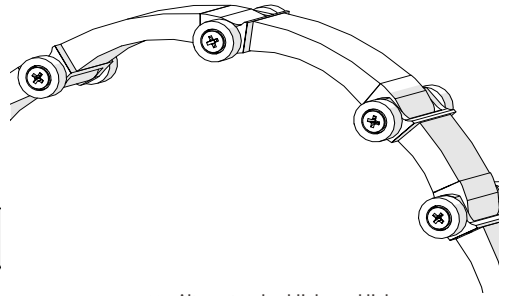

Fig. 102 - Alternate wheel links and links

1. Do not connect a link of any size directly to another link (Fig. 101).
2. Alternate wheel links and links ensuring links are always separated by a wheel link (Fig. 102).

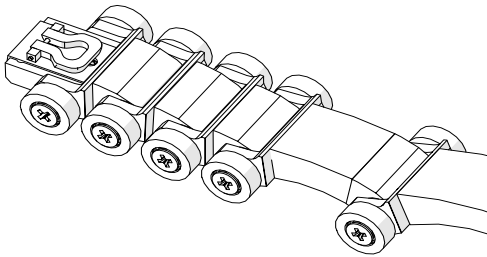

Fig. 103 - Connect wheel links to latch

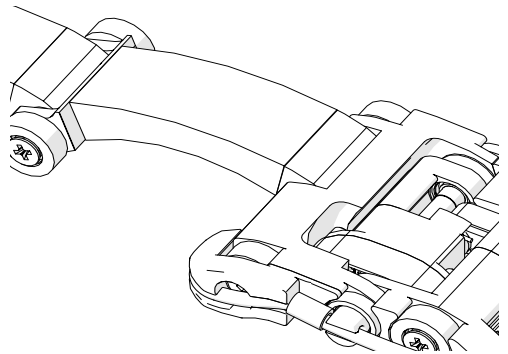

Fig. 104 - No wheel link between scanner and link

3. When the number of wheel links required (according to the chain configuration chart) is more than the required links, connect the additional wheel links to the latch end of the chain configuration (Fig. 103).
4. A wheel link is not required when connecting the scanner's link mount (Fig. 28-L) to the chain configuration (Fig. 104).

MAINTENANCE

General cleaning of components is important to keep your system working well. All components that have no wiring or cables are completely waterproof. Components can be washed with warm water, dish soap and a medium bristle brush.

Before using the scanner, ensure all connectors are free of water and moisture.

NOTE: *All components with wiring, cables or electrical connections are splashproof. However, these components are **NOT** submersible.*

NOTE: *Never use strong solvents or abrasive materials to clean your scanner components.*

TROUBLESHOOTING

Problem	Possible Cause	Solution
Chain is too loose/tight.	Incorrect number or combination of links.	Refer to the CIRC-IT setup chart (see <i>CIRC-IT Setup Chart on page 54</i>) to assemble the correct configuration for the size of pipe/tube being scanned.
	Incorrect latch setting.	Ensure the latch is set using the tightest notch possible (see <i>Latch Connection on page 40</i>).
	Incorrect latch used.	When scanning pipe/tube with an OD less than 50.8 mm (2 in), the short latch must be used. When scanning pipe/tube with an OD greater than 50.8 mm (2 in), the long latch must be used (see <i>CIRC-IT Setup Chart on page 54</i>).
Insufficient probe contact.	Scanner not set properly.	Reconfigure the scanner as per instructions (see <i>Setup of CIRC-IT on a Pipe or Tube on page 14</i>).
	Pivot adjustment screws were not adequately tightened.	Reconfigure the scanner as per instructions (see <i>Setup of CIRC-IT on a Pipe or Tube on page 14</i>) and ensure pivot adjustment screws are tight.
	Setup tab not raised.	Ensure the setup tab has been raised and the screws tightened. (see <i>step 13 on page 18</i>). Setup tab are located on each side of a dual probe scanner.
	Cables and/or hoses are routed incorrectly.	Ensure the cables and hoses are not impeding proper scanner operation.
Clearance issues when scanning small diameters.	Remove encoder cable guard.	(see <i>Setup on diameters smaller than 31.75 mm (1.25 in) on page 18</i>)

9.1. Technical Support

For technical support contact Jireh Industries (see *Jireh Industries Ltd. on page 1*).

SERVICE AND REPAIR



WARNING! DO NOT DISASSEMBLE. No user-serviceable parts. Disassembling any of the components in this product, beyond the instructions in this user manual, could void the regulatory certifications and/or effect the safety of the product.

SPARE PARTS

To order accessories or replacement parts for your CIRC-IT system.
(contact Jireh Industries Ltd. on page 1)

NOTE: These drawings are for parts order. This is not a list of kit contents.

11.1. CIRC-IT Components

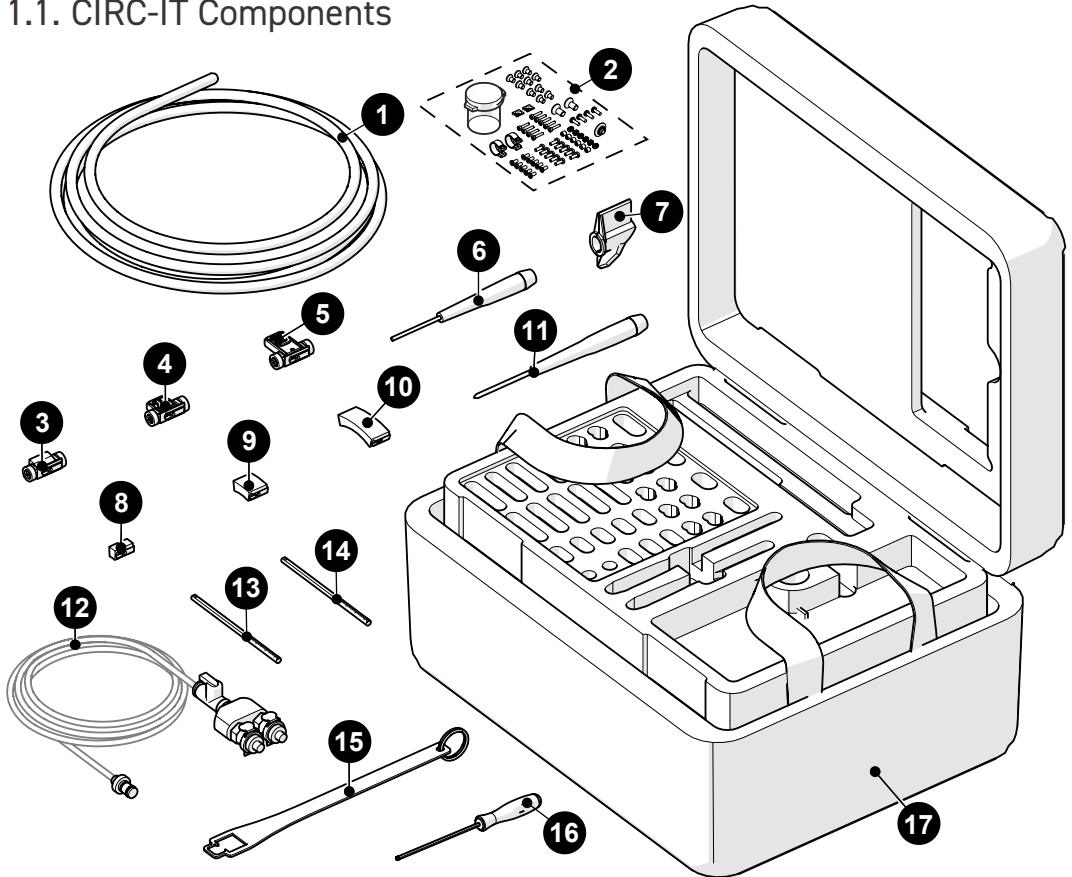

BOM ID	Part #	Description	BOM ID	Part #	Description
1	DG0123-0.600	Cable Sleeving	9	DJS013-1.125	Medium Link
2	DJG002	CIRC-IT Spare Fasteners	10	DJS013-1.815	Long Link
3	DJS006	Wheel Link	11	EA307	Phillips Driver
4	DJS008	Short Latch	12	DJS020	Irrigation Splitter
5	DJS012	Long Latch	13	DJ0034-094	Crossbar
6	EA303	Torx® Driver	14	DJ0034-069	Crossbar
7	EA302	Loom Installation Tool	15	DJS018	Chain Retrieval Tool
8	DJS013-0.735	Short Link	16	EA476	2 mm Hex Driver
			17	DJA002	CIRC-IT Case

Fig. 105 - CIRC-IT spare parts

11.2. CIRC-IT Scanner

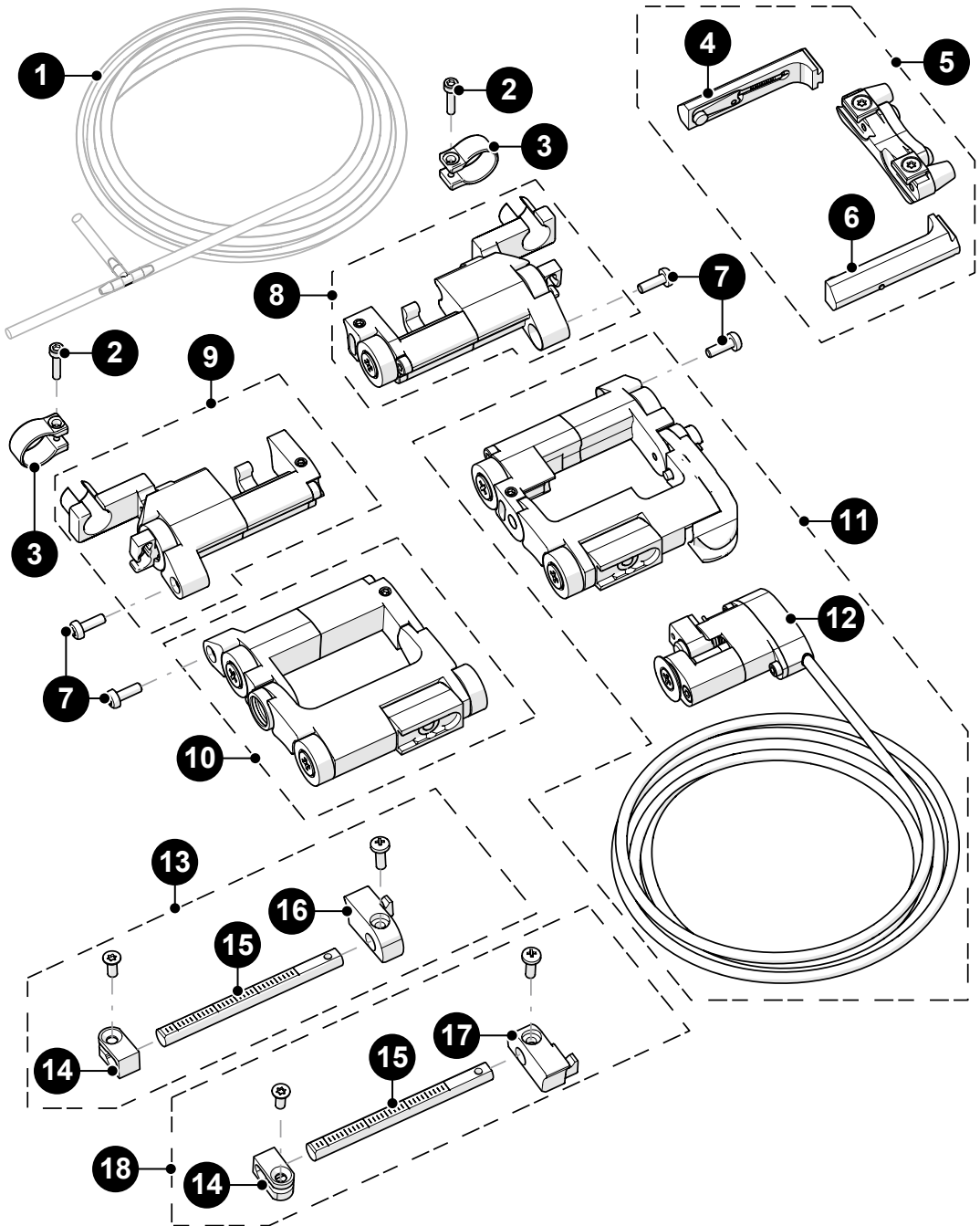

Fig. 106 - CIRC-IT scanner parts

BOM ID	Part #	Description
1	DJS017	Irrigation tube
2	MD046-008	Sleeve clamp screw, SHCS, M1.6x0.35 X 8mm, SST
3	DJ0013	Sleeve clamp
4	DJS001-R	Probe holder arm, right
5	DJS002	Probe holder
6	DJS001-L	Probe holder arm, left
7	MA125	PHMS-TX, M2x6 ISO 14583 A2-SST TORX
8	DJS007	Primary swing arm, right
9	DJS0010	Secondary swing arm, left
10	DJS009	Encoderless link
11	DJS023-X	Encoded link (<i>see Encoder Connector Type</i>)
12	DJG004-X	CIRC-IT encoder (<i>see Encoder Connector Type</i>)
13	DJS011-R	Crossbar assembly, right
14	DJS027	Wedge separation indicator
15	DJ0034-X	Crossbar (<i>see Crossbars</i>)
16	DJS026-R	Crossbar clamp bracket, right
17	DJS026-L	Crossbar clamp bracket, left
18	DJS011-L	Crossbar assembly, left

11.2.1. Encoder Connector Type

Connector Type	Company/Instrument	Connector Type	Company/Instrument
B	Olympus OmniScan MX Zetec Topaz	G	Sonotron Isonic 25xx
C	Olympus Focus LT Zetec Z-Scan Eddyfi Ectane 2	U	Sonatest Veo / Prisma
E	Olympus OmniScan SX/MX2/X3 M2M MANTIS/GEKKO LEMO	V	Pragma PAUT
F	TD (<i>Technology Design</i>)	AD	Sonatest Veo / Prisma - Single Axis

NOTE: Additional encoder connector styles available.(contact Jireh Industries Ltd. on page 1).

11.3. Accessories

11.3.1. Crossbars



Part #	Length	
DJ0034-044	44 mm (1.7 in)	
DJ0034-069	69 mm (2.7 in)	
DJ0034-094	94 mm (3.7 in)	
DJ0034-119	119 mm (4.7 in)	

Fig. 107 - Crossbars

11.3.2. CIRC-IT Spare Parts Kit

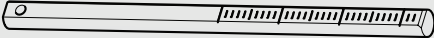

Part #	Description
DJG003	CIRC-IT Spare Parts Kit

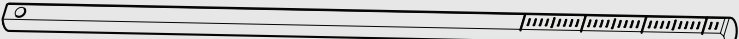
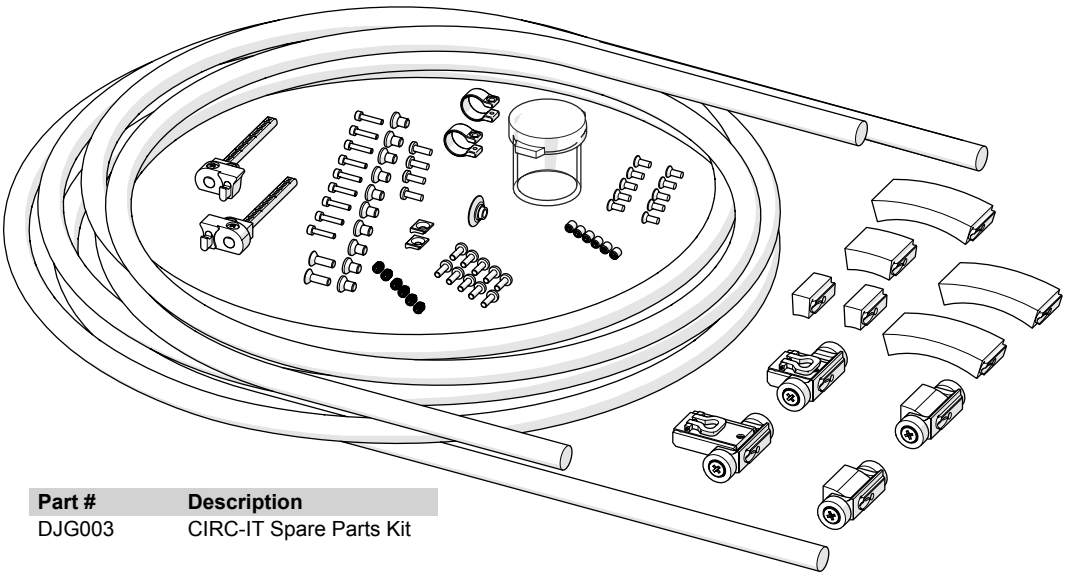
Fig. 108 - CIRC-IT spare parts kit

11.3.3. CIRC-IT Spare Wheels Kit

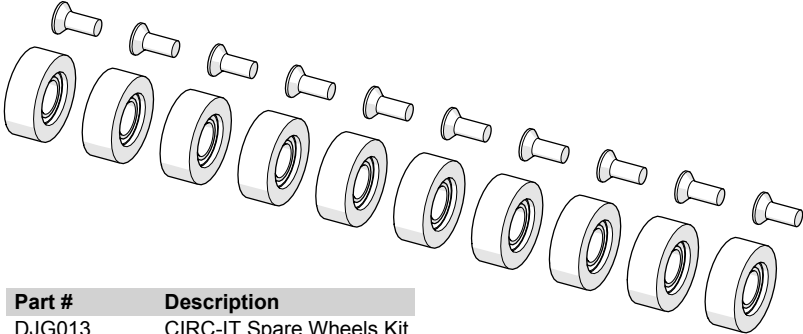

Part #	Description
DJG013	CIRC-IT Spare Wheels Kit

Fig. 109 - CIRC-IT spare wheels kit

DISPOSAL

WEEE Directive

In accordance with European Directive on Waste Electrical and Electronic Equipment (WEEE), this symbol indicated that the product must not be disposed of as unsorted municipal waste, but should be collected separately. Refer to Jireh Industries for return and/or collection systems available in your country.



LIMITED WARRANTY

WARRANTY COVERAGE

Jireh Industries warranty obligations are limited to the terms set forth below: Jireh Industries Ltd. (“Jireh”) warrants this hardware product against defects in materials and workmanship for a period of THREE (3) YEARS from the original date of purchase. If a defect exists, at its option Jireh will (1) repair the product at no charge, using new or refurbished replacement parts, (2) exchange the product with a product that is new or which has been manufactured from new or serviceable used parts and is at least functionally equivalent to the original product, or (3) refund the purchase price of the product. A replacement product/part assumes the remaining warranty of the original product or ninety (90) days from the date of replacement or repair, whichever provides longer coverage for you. When a product or part is exchanged, any replacement item becomes your property and the replaced item becomes Jireh’s property. When a refund is given, your product becomes Jireh’s property.

OBTAINING WARRANTY SERVICE

To utilize Jireh’s warranty service you must ship the product, at your expense, to and from Jireh Industries. Before you deliver your product for warranty service you must phone Jireh and obtain an RMA number. This number will be used to process and track your product. Jireh is not responsible for any damage incurred during transit.

EXCLUSIONS AND LIMITATIONS

This Limited Warranty applies only to hardware products manufactured by or for Jireh Industries. This warranty does not apply: (a) to damage caused by accident, abuse, misuse, misapplication, or non-Jireh products; (b) to damage caused by service (including upgrades and expansions) performed by anyone who is not a Jireh Authorized Service Provider; (c) to a product or a part that has been modified without the written permission of Jireh.

Jireh Industries Ltd.
53158 Range Rd 224
Ardrossan, AB T8E 2K4
Canada

Phone: 780-922-4534

jireh.com

All brands are trademarks or registered trademarks of their respective owners and third party entities.

Changes or modifications to this unit or accessories, not expressly approved by the party responsible for compliance could void the user's authority to operate the equipment.

All specifications are subject to change without notice.

© 2017 - 2023 Jireh Industries Ltd.

APPENDIX

14.1. CIRC-IT Setup Chart

SHORT LATCH REQUIRED									
OUTER Ø RANGE				LINK TYPE				PIPE OD	TUBE OD
MIN (in)	MAX (in)	MIN (mm)	MAX (mm)	SHORT	MEDIUM	LONG	WHEEL	(in)	(in)
0.84	0.94	21	24	0	0	0	0	0.84	0.88
0.94	1.03	24	26	1	0	0	0		1.00
1.02	1.11	26	28	0	0	0	1	1.05	
1.11	1.20	28	30	1	0	0	1		1.13
1.20	1.28	30	33	0	0	0	2		
1.28	1.37	33	35	1	0	0	2	1.32	1.32
1.37	1.45	35	37	0	0	0	3		1.38
1.45	1.53	37	39	1	0	0	3		1.50
1.53	1.62	39	41	0	0	0	4		
1.61	1.70	41	43	1	0	0	4	1.66	
1.70	1.78	43	45	0	0	0	5		1.75
1.78	1.86	45	47	1	0	0	5		
1.86	1.95	47	49	0	0	0	6	1.90	
1.94	2.03	49	51	1	0	0	6		2.00

LONG LATCH REQUIRED									
OUTER Ø RANGE				LINK TYPE				PIPE OD	TUBE OD
MIN (in)	MAX (in)	MIN (mm)	MAX (mm)	SHORT	MEDIUM	LONG	WHEEL	(in)	(in)
2.01	2.15	51	55	0	1	0	5		
2.14	2.28	54	58	1	2	0	4		2.25
2.27	2.41	58	61	0	3	0	4	2.38	
2.38	2.52	61	64	0	2	0	6		2.50
2.51	2.64	64	67	1	3	0	5		2.50
2.64	2.77	67	70	0	4	0	5		
2.76	2.89	70	73	0	1	2	4	2.88	
2.88	3.01	73	76	0	3	1	5	2.88	
2.99	3.12	76	79	0	0	3	4		3.00
3.11	3.24	79	82	0	2	2	5		
3.23	3.37	82	86	0	4	1	6		3.25
3.34	3.47	85	88	0	1	3	5		
3.47	3.60	88	91	0	3	2	6	3.50	3.50
3.57	3.70	91	94	0	0	4	5		
3.69	3.83	94	97	0	2	3	6		3.75
3.80	3.93	96	100	1	0	4	6		
3.92	4.05	100	103	0	1	4	6		
4.00	4.13	101	105	1	1	4	6	4.00	4.00
4.12	4.25	105	108	0	2	4	6		
4.19	4.32	106	110	1	2	4	6		
4.31	4.45	110	113	0	3	4	6		
4.42	4.55	112	115	1	1	5	6	4.50	4.50
4.54	4.67	115	119	0	2	5	6		

Fig. 110 - Setup chart



Jireh Industries Ltd.
53158 Range Road 224
Ardrossan, Alberta
Canada
T8E 2K4

780-922-4534

jireh.com