



**Eddyfi
Technologies**
Beyond current

Getting Started with

VERSATRAX™ I100

VERSATRAX™ P205



Table of Contents

About This Manual.....	5
System Description.....	5
Precautions	6
Certification	6
Safety.....	6
Intended Use.....	9
System Setup.....	9
Personnel Requirements	9
Working and Storage Environment.....	10
System Power	11
ICON™ Portable Controller / Interface Box Connection.....	11
Vehicle and Tether Connection	11
Vehicle Tether Connection.....	12
Portable Reel Setup.....	13
Mini-Reel Setup.....	14
Tether Handling.....	15
Connector Handling	15
SubConn Connectors: Lubrication and Cleaning.....	16
Impulse Connectors: Lubrication and Cleaning	16
Vehicle Configuration.....	17
VT-P205 Short Chassis	17
Track Angle Adjustment	17
Camera Height Adjustment.....	18
Camera Height Extensions	19
Camera & Light Installation.....	20
Track Mounting – Short Chassis.....	23
Traction Weight Kit.....	24

Magnet Kit.....	25
VT-P205 Extended Chassis.....	28
Track Angle Adjustment	28
Spectrum™ 90 and 801 Light Installation.....	29
Spectrum™ 45 Mount.....	30
Track Mounting – Extended Chassis.....	31
Extended Traction Weight Kit	32
Extended Magnet Kit.....	33
VT-I100	34
Track Installation	34
100 mm (4 in) Configuration	35
125 mm (5 in) Configuration	36
150 mm (6 in) Configuration	37
Rear Camera	38
Front Sapphire™ Camera.....	39
Operation	40
Pre-Operations Check	40
Post-Operations Check.....	41
ICON™ Software.....	42
Dealing with Obstacles	42
Troubleshooting.....	42
Camera Control Problems	42
Video Problems.....	43
Vehicle Problems	43
Reel Problems.....	44
Maintenance.....	45
Galvanic Corrosion Control.....	45
Rinsing and Cleaning.....	46
Fuse Replacement.....	47
Track Maintenance	48

Camera Maintenance	48
Tether Re-termination	48
Parts and Repairs.....	49
Ordering Parts/Customer Service.....	49
Warranty Repairs.....	50
Factory Returns to Canada	50
Product/System Drawing Package Availability.....	50
Limited Warranty Policy	50

About This Manual

This manual has been prepared to assist you in the operation and maintenance of your Eddyfi Technologies equipment. Correct and prudent operation rests with the operator who must thoroughly understand the operation, maintenance, service, and job requirements. The specifications and information in this manual are current at the time of printing.

This product is continually being updated and improved. Therefore, this manual endeavors to explain and define the functionality of the product. Furthermore, schematics or pictorials and detailed functionality may differ slightly from what is described in this manual.

Eddyfi Technologies reserves the right to change and/or amend these specifications at any time without notice. Information in this manual does not necessarily replace specific regulations, codes, standards, or requirements of others such as government or site regulations.

This manual is copyright © 2023 by Eddyfi Robotics Inc. All rights reserved.

System Description

The VersaTrax™ I100 and VersaTrax™ P205 vehicles are a system of pipeline inspection vehicles based on tracks. Covering In-Line and Parallel chassis configurations, the vehicles will navigate pipes of 100 – 300 mm (4 – 12 in) internal diameter with the camera centered. The track mechanism is further adjustable to very large diameters or flat surfaces.

The inspection system has been manufactured with the hazards and demands of pipe inspection in mind. A minimized vehicle profile provides maximum clearance for passage of service intrusions in the pipe. The vehicle employs marine technology for underwater operation down to a depth of 60 m (200 ft).

Document: UMDT013103.docm	Revision: A20	Created by: KJB	Date: 16 Oct 2023	3070984-A22
Source Location: C:\ePDM\ISLEng\products\dt-versatrax100mkii\manuals\UMDT013103.docm				Page 5 of 50

Precautions



IMPORTANT: When configuring a 70V system, check to see if the tracks are compatible. Older versions of tracks are not 70V compatible. Look for the Wide Input Voltage symbol **WV** located on the side plate of the track indicating 70V compatibility.

Certification

The VT-I100 and VT-P205 systems are built in accordance with the Low Voltage Directive 2014/35/EU, Machinery Directive 2006/42/EC, and Electromagnetic Compatibility Directive 2014/30/EU.



Safety

To use this product properly and safely, every user must first read these operating instructions and observe the safety instructions contained therein. Take care of these operating instructions and keep them in a place where they can be accessed by everyone. Untrained personnel should not handle or operate this equipment.



CAUTION: Failure to follow these safety instructions may result in injury or equipment damage.



WARNING: Hazardous Voltage 36-70 VDC. If the equipment is powered from a source other than an Eddyfi Technologies provided controller, the power supplied to the product must have reinforced isolation from the mains with no reference to earth ground.



CAUTION

Interaction with metallic objects may produce Pinch Hazards.
Persons with Medical Implants
KEEP BACK 12 inches.

Strong Magnetic Field

WARNING: Magnetic Pinch Hazard – The magnetic chassis options are fitted with rare earth magnets. These magnets are very strong and create an abrupt pinch hazard. Use caution when handling the magnets or vehicle near steel objects and tools, they may snap together unexpectedly.

WARNING: Medical Hazard – Operators with magnetically sensitive medical implants should be aware of and follow appropriate practices.

WARNING: Electronic Device Interference – Magnetically sensitive devices, including computer hard

drives, cell phones, watches and credit cards may be disrupted or damaged by the magnetic field.

Note: Rare earth materials are mechanically weak, and magnetically very strong. They must therefore be handled very carefully to avoid damage.

 **Note:** To reduce risk of injury and damage to equipment, always store the VersaTrax™ 205 vehicle option in its **magnetically shielded storage and shipping box** or store the magnets on a **steel plate** when not in use. 

 **Note:** We strongly recommend using gloves when handling the vehicle to reduce magnetic pinching hazard. 

 **Warning: Avoid Magnetic Slamming.** Extreme care must be taken when handling a magnet equipped vehicle, particularly when placing it onto a steel surface or into its storage box. Without taking heed of the sudden pull of the magnetic field onto a surface, the vehicle can be slammed down hard causing damage to the vehicle. Using a solid grip on the vehicle, we recommend touching down the vehicle by one end first and then pivoting flat. 

 **WARNING: Intense Optical Radiation** - The LineTrax™ 100 and VersaTrax™ 205 camera lights are extremely bright. Never look directly at the lights. Use a welding filter (shade #8 or higher) if inspecting the LEDs.

- **CAUTION: Class II Lasers** are built into the Spectrum™ 90 camera. Do not intentionally stare into the beam. Typically, Class II relies on the blink reflex to limit exposure to no more than ¼-second. Intentionally staring into the beam can cause eye injury.
- When performing maintenance or functional checks of the Spectrum™ 90 lasers and camera lights, take precautions to protect nearby personnel from unintended exposure which could be temporarily blinding.
- Observe safe lifting practices. For storage and shipping, the VT-I100 and VT-P205 vehicles are packed in three parts: Controller, Vehicle and Tether. Each of the three components is either built or packed into a Pelican case with carrying handle. The heaviest case containing the tether and Mini-Reel is equipped with wheels and extending handle like a suitcase.
- Do not operate the system with damaged wires. A short circuit may damage the power system, telemetry system, cameras, or attached equipment. Exposed wires may also create a shock hazard.

 The linked image cannot be displayed. The file may have been moved, renamed, or deleted. Verify that the link points to the correct file and location.

- Disconnect the power source before servicing the product; otherwise, damage may result.
- Although designed for durability, the vehicle and its components or attached devices may suffer structural damage if dropped or impacted.
- All personnel operating or maintaining this equipment must be trained and competent.
- Eddyfi equipment is used in many varied environments from hot/dry to confined spaces to deep underwater. Such diverse environment risks must be addressed by the operators who are trained to work in such surroundings. As such, the operator is responsible to determine safe site setup and appropriate personal protective equipment (PPE) for deployment, operation and maintenance of the equipment.



WARNING: Spark Hazard - Under no circumstances should this equipment be used in a potentially explosive atmosphere.



WARNING: Trip Hazard - Never stand on the tether. A snap load to the tether may pull it out from underneath you and cause you to fall. Standing on the tether may also damage its internal conductors, cause unnecessary wear, and decrease its life.



WARNING: High Temperature - The Spectrum™ 90 camera head and auxiliary lights may become extremely hot during operation. Allow a cool-down period before handling.



WARNING: Falling Object – Magnetic attachments for the VT-P205 are not intended for vertical or inverted operation; rather, they are intended to provide additional downforce for traction in place of extra weights.

Intended Use

VT-I100 and VT-P205 are industrial inspection vehicles intended for navigating pipelines and ground/floor surfaces with a mild slope. The vehicles primarily provide close-up or zoom video of the inspection target, which could be a weld, paint covering, surface corrosion, etc. All VT-I100 and VT-P205 hardware can be used dry, underwater up to 60 m (200 ft) deep, or in dirty, muddy conditions. The rugged design ensures a long service life and helps protect the vehicle from damage during normal use.

Typical applications include inspection of:

- Sewer and storm drains
- Hydroelectric pipe and infrastructure
- Nuclear Infrastructure
- Tanks and pressure vessels
- Oil and gas refineries and pipelines
- Pulp and paper mills
- Underwater weld and paint inspection
- Potable water system inspection
- Mobile robotics and remote sensing

Misuse of the system is deployment in a situation for which it is not rated, or incorrect handling.

Examples of misuse include:

- In a vacuum
- Beyond its depth rating without factory approval
- Above or below its temperature rating
- Use in a potentially explosive atmosphere
- Use in incompatible chemical environments
- Very high radiation environments (Beta / Gamma)
- Prolonged overload (Payload or pulling load)
- Camera pointed at the Sun or at intense lighting
- Mechanical impacts & scraping during deployment / magnetic slamming / dropping
- In salt water without an anode

System Setup

Personnel Requirements

Basic deployment of the VT-I100 and VT-P205 systems may be performed by one person. Operations at more complex worksites may require two people, especially when the console location is removed from the point of deployment.

- **Console Operator:** This person is responsible for driving the vehicle, watching the pipe and making comments about the location and pipe condition. It is also the operator's responsibility to assess whether a pipe is in the appropriate condition for safe passage of the vehicle or if there is

Document: UMDT013103.docm	Revision: A20	Created by: KJB	Date: 16 Oct 2023	3070984-A22
Source Location: C:\ePDM\ISLEng\products\dt-versatrax100mkii\manuals\UMDT013103.docm				Page 9 of 50

a risk of getting stuck. The operator may also assist in general site setup (cones, warning signs, etc.), vehicle maintenance and configuration.

- **Deployment / Tether Handler / Field Maintenance:** This person has several tasks including:
 - Configuring the vehicle for the current pipe
 - Lowering the vehicle in and out of the manhole
 - Watching the tether as the vehicle enters and exits the pipe
 - Operating the reel and winding the tether during recovery

Establish a good channel of communication between the operator and deployment personnel. Good communication can avoid accidents, damage to the equipment, and promotes efficiency and productivity. In particular, the person deploying the vehicle and watching the tether must be able to quickly tell the operator to stop the vehicle if something goes wrong. The operator should never turn on power or initiate movement without first communicating with the vehicle handler.

Working and Storage Environment

The control system (ICON™ Portable Controller or Interface Box and Control computer) is to be used in a **dry, covered** environment only. These components are not waterproof. Keep all cords and cables away from water.

The **tether and vehicle** are depth rated to 60 m (200 ft). The tether connector is a wet-mate type which may be wet when plugged in but cannot be plugged in underwater. Keep the tether connector capped with a dummy plug when not connected to the vehicle to help keep out dirt. The tracks are tolerant to sandy and muddy conditions, although this decreases seal life. The vehicle may also be operated in dry or dusty environments.

The portable reel is splash resistant only. Refer to the reel manual.

To maximize component life and minimize deployment time it is recommended that the vehicle and tether be cleaned after use and the entire system stored in a dry, dust free, location.

Refer to the Specifications section for operating and storage temperatures.

Document: UMDT013103.docm	Revision: A20	Created by: KJB	Date: 16 Oct 2023	3070984-A22
Source Location: C:\ePDM\ISLE\products\dt-versatrax100mkii\manuals\UMDT013103.docm				Page 10 of 50

System Power

The VT-I100 and VT-P205 are operated through an ICON™ Portable Controller, or a Rackmount Interface Box. These controllers provide power to the tether and vehicle.

Refer to the ICON™ Portable Controller or Interface Box manuals for further details and power requirements.

If powering the system from a generator or inverter, refer to that unit's operating manual for recommendations on continuous and peak load ratings. These power sources may apply a reduced output rating based on electrical load and environmental temperature. Remember to include the power needs of all other connected devices (external monitors, recording devices, lighting, etc.) when selecting a generator or inverter.

ICON™ Portable Controller / Interface Box Connection

The ICON™ Portable Controller supplies power to the tether and vehicle. It provides a communication interface to the vehicle. It also provides video reception and distribution. Alternatively, when using a laptop or other computer, an Interface Box will perform these functions.

Refer to the Controller Setup section of the ICON™ Portable Controller or Interface Box user manual for more information.

Vehicle and Tether Connection

The tether and vehicle are depth rated to 60 m (200 ft) of water. The tether connector and track connectors are dry-mate types which must be dry when making a connection. Keep the tether connector capped with a dummy plug when not connected to the vehicle to help keep out dirt.

It is important that the tether be properly connected to the vehicle.

1. Connect the vehicle end of the tether to the back of the harness block. Visually line up the key in the connector before mating. Fully screw down and hand tighten the locking collar.
2. Verify the track and camera whips from the harness block to their respective components are securely connected, and the whips are free from damage.

Document: UMDT013103.docm	Revision: A20	Created by: KJB	Date: 16 Oct 2023	3070984-A22
Source Location: C:\ePDM\ISLE\products\dt-versatrax100mkii\manuals\UMDT013103.docm				Page 11 of 50

Vehicle Tether Connection

It is important that the tether be properly connected to the vehicle; otherwise, system damage or loss of the vehicle may result. The tether attachment procedure is the same for VT-I100 and VersaTrax™ 205.

3. Confirm the connector pins on the vehicle and tether are clean and lightly lubricated with silicone grease (Molykote 111 or equivalent).
4. Visually line up the connector pins and push the connector all the way on.
5. Fully screw down and hand tighten the locking collar.
6. Secure the strain relief lanyards onto the spring-pin clips as illustrated below. If the pull-tabs on the spring pins have been removed, the pins may be pushed up from the bottom using a small screwdriver.
7. Confirm the lanyards are also secured to the tether splice block. Lanyards should remain permanently attached to the splice block.

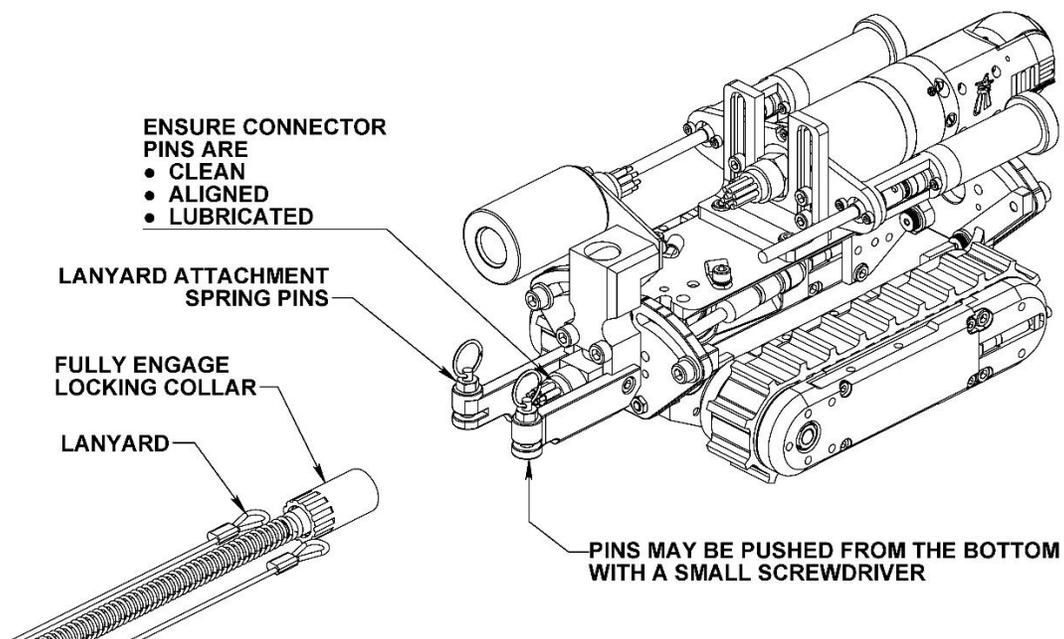

Portable Reel Setup

If your system includes a portable reel, follow these steps to operate:

1. Remove the shipping cap from the front of the case and insert the crank handle.
2. Connect the deck cable from the reel to the controller.
3. Disengage the packing brake (pull back and turn on the locking pin).
4. Make sure the friction brake is **engaged** - disengaging the friction brake can result in slack tether resulting in potentially jamming the reel.
5. Unwind some tether and connect the tether to the vehicle.
6. Run the tether through the level wind as follows:
 - a. There is an access slot which must be opened by lifting up on the two exposed screw heads to raise the tether support shafts.
 - b. Pull up on both sides of the axle on the top wheel and slide the tether beneath it - failing to lift up on the wheel can scuff and damage the tether.
 - c. Make sure that the two wheels that sandwich the tether top and bottom in the level wind are tracking properly as the tether is paid out - this tells the controller how much tether the reel has unwound and how far your vehicle has travelled.

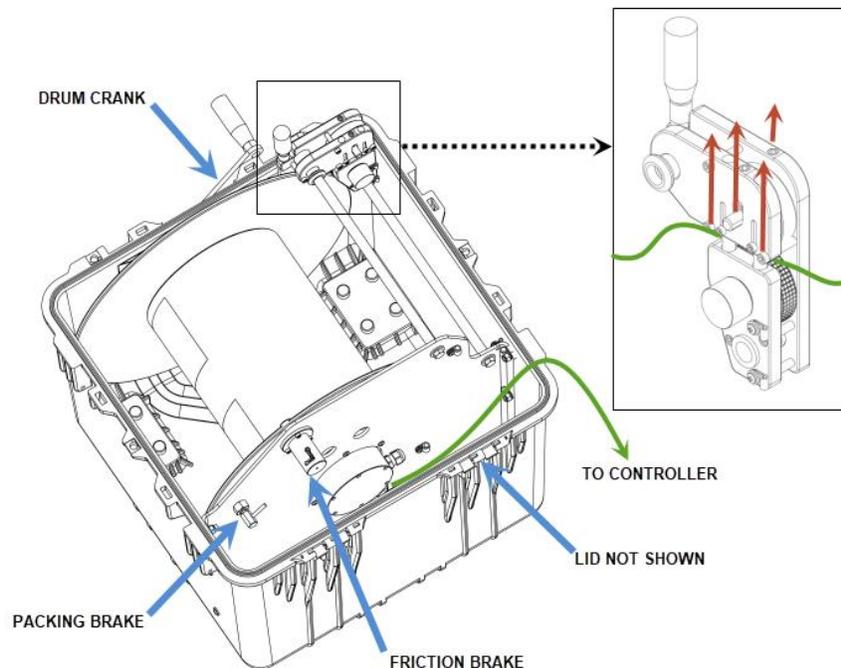

Mini-Reel Setup

If your system includes a Mini-Reel, follow these steps to operate:

1. Remove the Mini-Reel from the shipping case.
2. Connect the deck cable from the reel to the Video Interface and Power Supply.
3. Connect the encoder deck cable from the reel to the Video Interface and Power Supply (if provided with Mini-Reel).
4. **Disengage** the shipping brake.
5. Make sure the friction brake is **engaged** – disengaging the friction brake can result in slack tether resulting in potentially jamming the reel.
6. Unwind some tether and connect the tether to the vehicle.

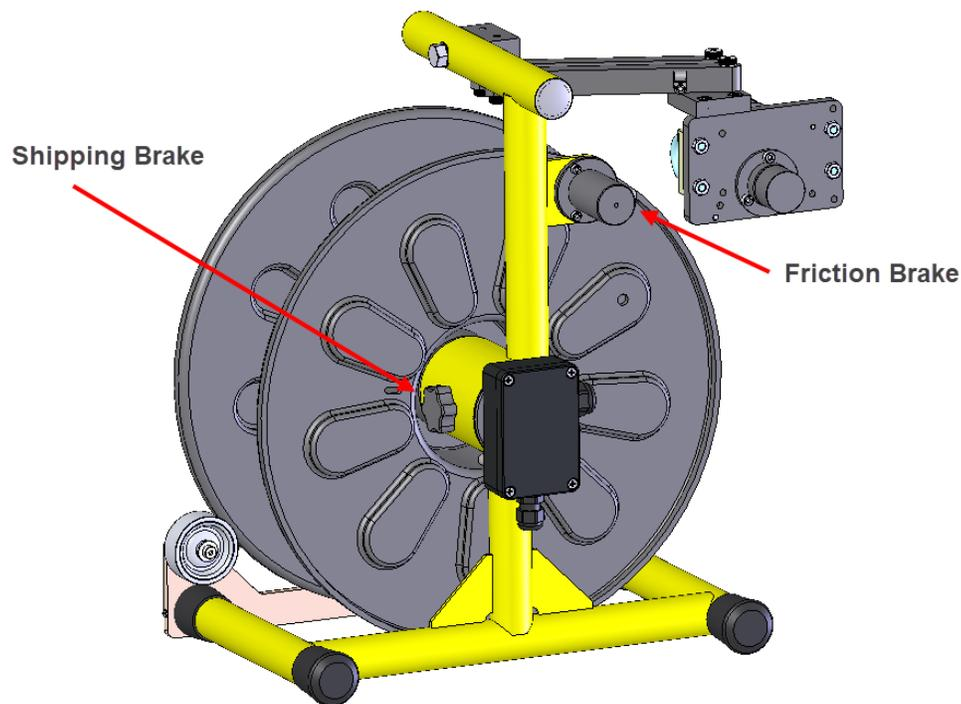

Tether Handling

The tether is one of the most important parts of the system. It feeds power and control signals to the system and returns data to the controller. If the tether is damaged from improper use, poor handling or an accident, the system may become inoperable. This could lead to significant downtime, loss of production, and avoidable costly repairs. It is encouraged to stress the importance of the tether and its care to anyone operating or maintaining the system. For maximum tether life and reliability, we recommend the following tether handling tips.

- Do not step on the tether.
- Do not drive over the tether.
- Do not bend the tether beyond its minimum bend radius.
- Do not kink the tether.
- Do not snap load the tether.
- Avoid loading the tether whenever possible.
- Always use the cable grip strain relief if applicable to your system.
- Regularly inspect the tether for damage.
- Regularly clean the tether.

Note: Protecting the conductors inside the tether is critical to the life and operation of the tether. Proper tether handling and care will result in extended tether life and system reliability.

Connector Handling

Connectors are an essential part of system reliability. They should be properly maintained and cared for to ensure long life and reliability. It is recommended to follow these steps to help prevent damage and increase the life of connectors.

- Always put the cap back on the tether bulkhead when the tether is disconnected.
- Always inspect the end of the connector prior to engaging.
- Never plug in a dirty or damaged connector.
- Visually align keyways or locating pins prior to engaging the connector.
- Always fully engage or tighten the connector.
- Secure locking collars finger tight.
- Install dummy plugs on unused connectors.
- Disconnect by pulling straight, not on an angle.
- Do not pull on the cable to disengage the connector.



IMPORTANT: Never “Hot Plug” any connector, this will result in internal damage to the electronics. Power down the system prior to connecting the inspection system tether.



Never use WD-40 or similar solvent-based fluids on connectors or crawlers. These will cause the rubber parts of the connector or crawler to soften and swell rendering them inoperable.

Document: UMDT013103.docm	Revision: A20	Created by: KJB	Date: 16 Oct 2023	3070984-A22
Source Location: C:\ePDM\ISLEng\products\dt-versatrax100mkii\manuals\UMDT013103.docm				Page 15 of 50

SubConn Connectors: Lubrication and Cleaning

- Periodically apply Molykote 111 silicone grease or equivalent before mating connectors
- For dry mate connections, a layer of grease corresponding to 1/10 the socket depth should be applied to the female connector.
- After greasing, fully mate the male and female connector and remove excess grease from the connector joint.
- General cleaning and removal of sand or mud on a connector should be performed using a spray-based contact cleaner like isopropyl alcohol.

Impulse Connectors: Lubrication and Cleaning

- Lubricate mating surfaces regularly with 3M Silicone spray or equivalent, DO NOT GREASE
- Lubricate O-rings with Molykote 111 or equivalent.
- Use dust caps to protect connectors wherever possible.
- Clean connectors with soap and fresh water, rinse out with alcohol and allow connector to air dry before using.

Document: UMDT013103.docm	Revision: A20	Created by: KJB	Date: 16 Oct 2023	3070984-A22
Source Location: C:\ePDM\ISLEng\products\dt-versatrax100mkii\manuals\UMDT013103.docm				Page 16 of 50

Vehicle Configuration

VT-P205 Short Chassis

Track Angle Adjustment

The VT-P205 track angle may be continually adjusted from flat to 200 mm (8 in) ID pipe. To change the track angle, loosen the four M6 socket cap screws located in the end plate slots, move the track to its new angle, and retighten the screw. Indicator marks have been placed on the end plates for 200, 250, 300, and 600 mm (8, 10, 12, and 24 in) and FLAT configurations.

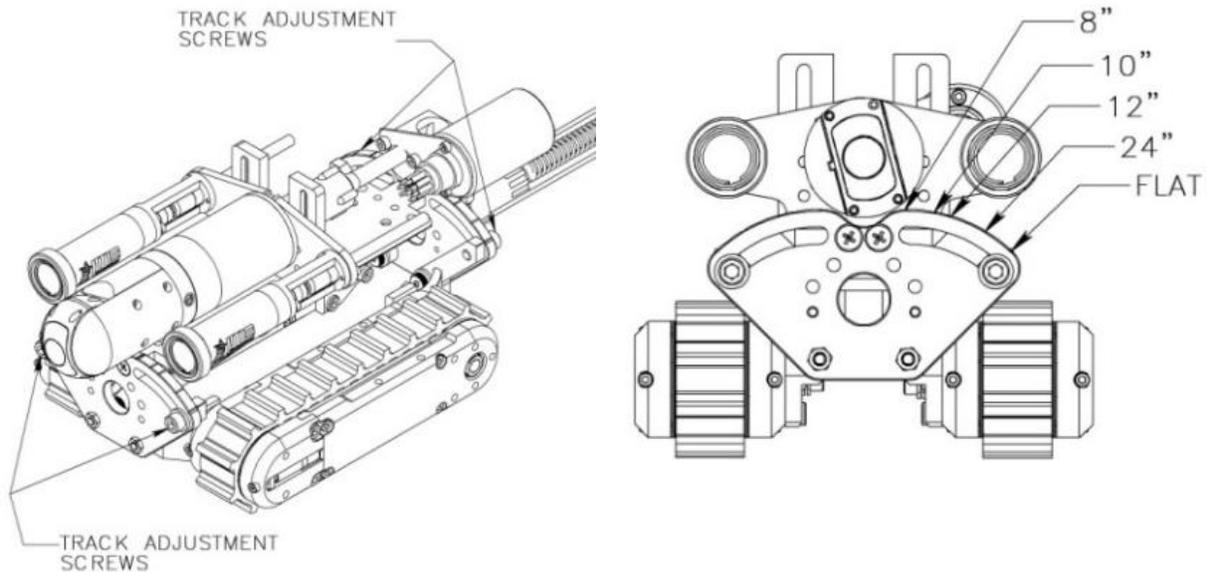

Camera Height Adjustment

Camera height is adjusted by loosening the four M5 SHCS in the camera slider, moving the camera to the required height and retightening the screws. In 305 mm (12 in) pipe, the upper adjustment screws are removed, and lower screws are placed at the top of the slot as illustrated below.

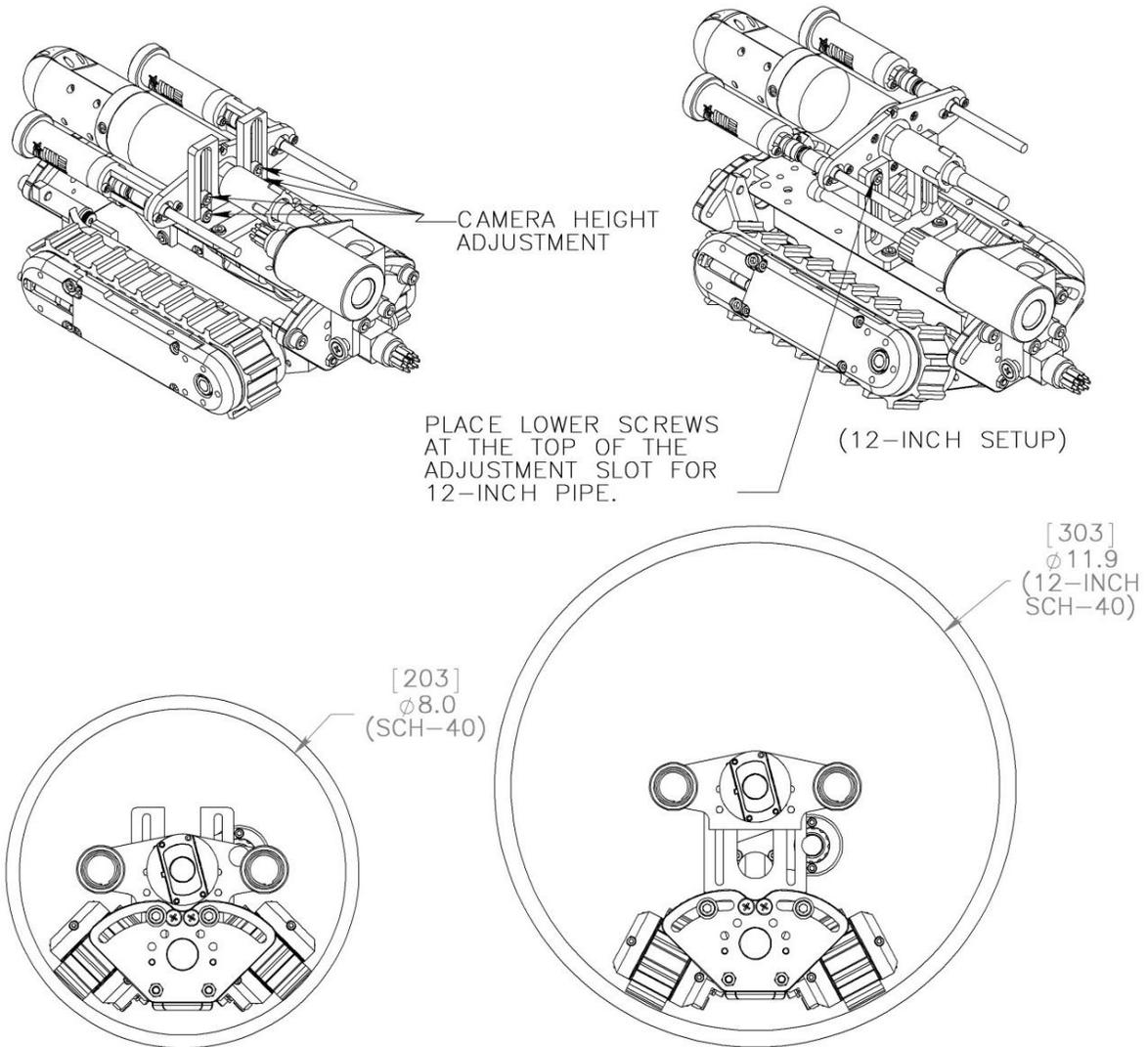

FIGURE 1: CAMERA HEIGHT ADJUSTMENT

Document: UMDT013103.docm	Revision: A20	Created by: KJB	Date: 16 Oct 2023	3070984-A22
Source Location: C:\ePDM\ISLEng\products\dt-versatrax100mkii\manuals\UMDT013103.docm				Page 18 of 50

Camera Height Extensions

An optional height extension kit may be added to the VT-P205 chassis to raise the camera by up to 150mm (6 in). Five brackets are included with the kit. Used in combination with the standard height adjustment, the kit allows for continuous adjustment to center the camera in pipe sizes from 300 – 600 mm (12 – 24 in).

CAMERA EXTENSION KIT
(3069627)

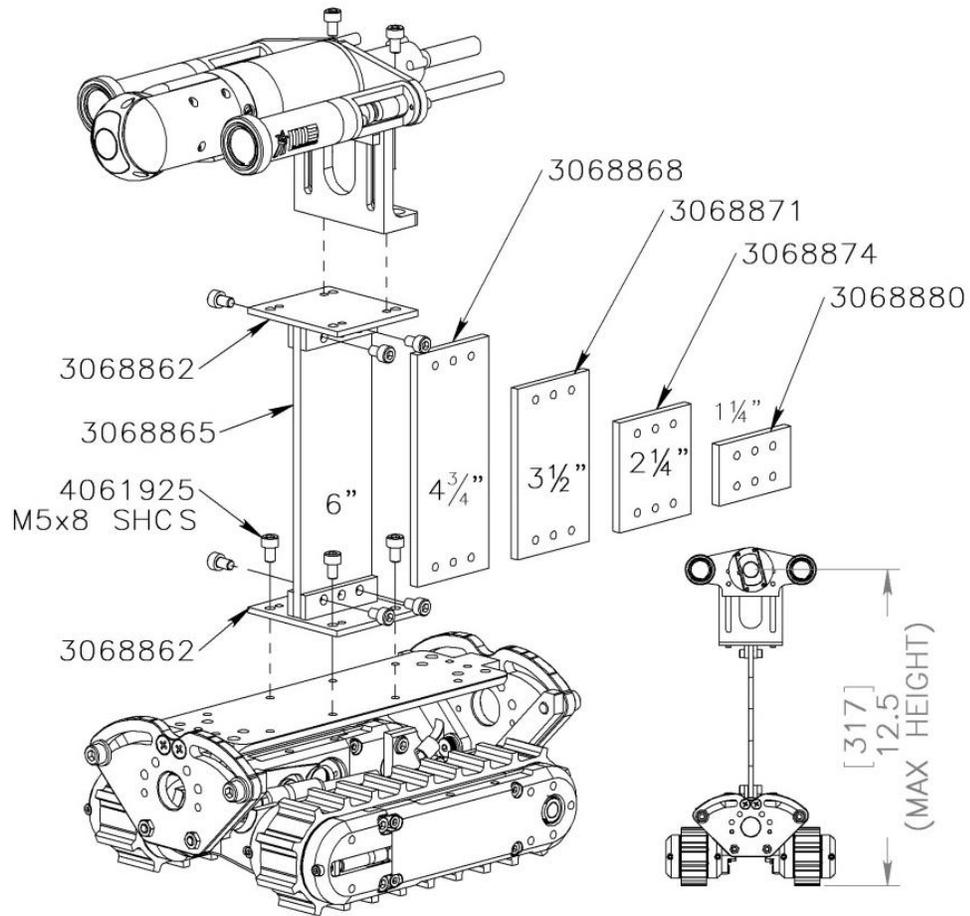

Camera & Light Installation

Spectrum™ 45

The front Spectrum™ 45 (SP45) camera is mounted to the vehicle using three M3 x 12 mm FHMS. There is a mark at the back of the camera which indicates the top for correct orientation.

Additional lighting is provided by two 801 Lights, installed using two M3 x 8 mm SHCS. Spacers move the lights forward to beside the camera.

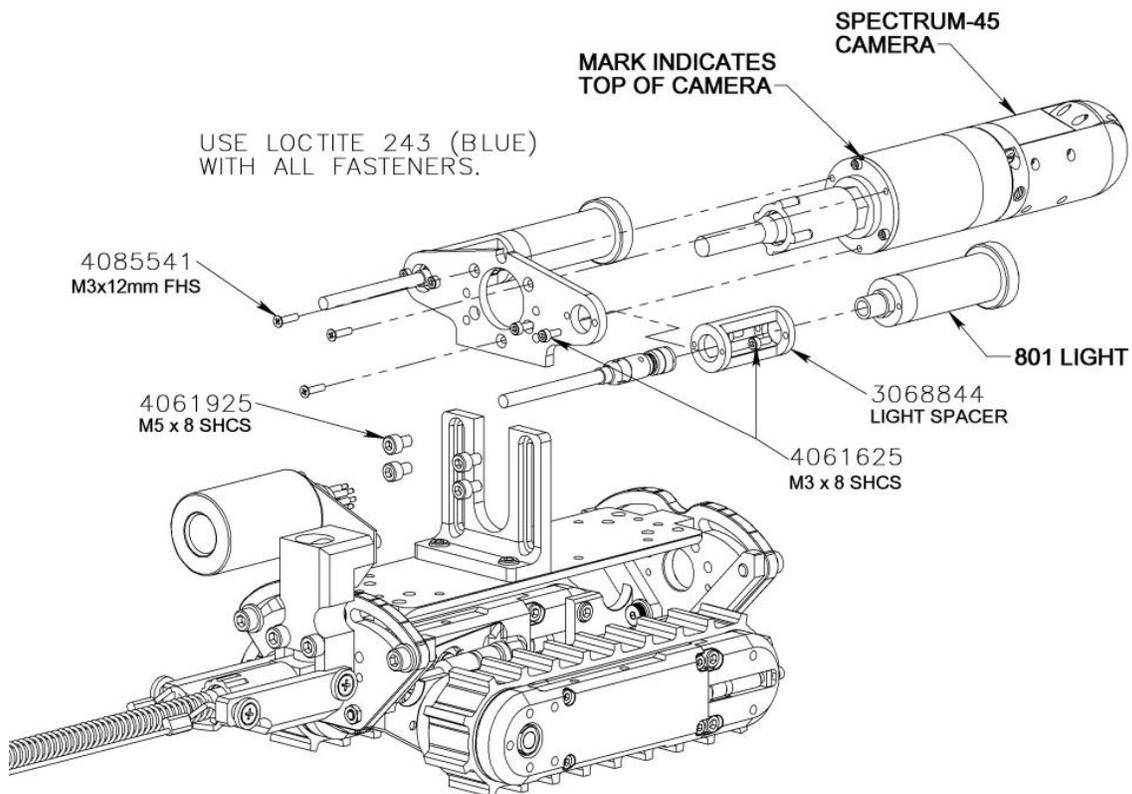

Spectrum™ 90

A Spectrum™ 90 (SP90) can be installed as an upgrade from the standard SP45 for this vehicle. Note: this requires a different harness as whip lengths will change.

Note: Installation of an SP90 may require the use of different fasteners when the system is equipped with a magnet tray. See the **Magnet Adjustment** section for more information.

Document: UMDT013103.docm	Revision: A20	Created by: KJB	Date: 16 Oct 2023	3070984-A22
Source Location: C:\ePDM\ISLEng\products\dt-versatrax100mkii\manuals\UMDT013103.docm				Page 20 of 50

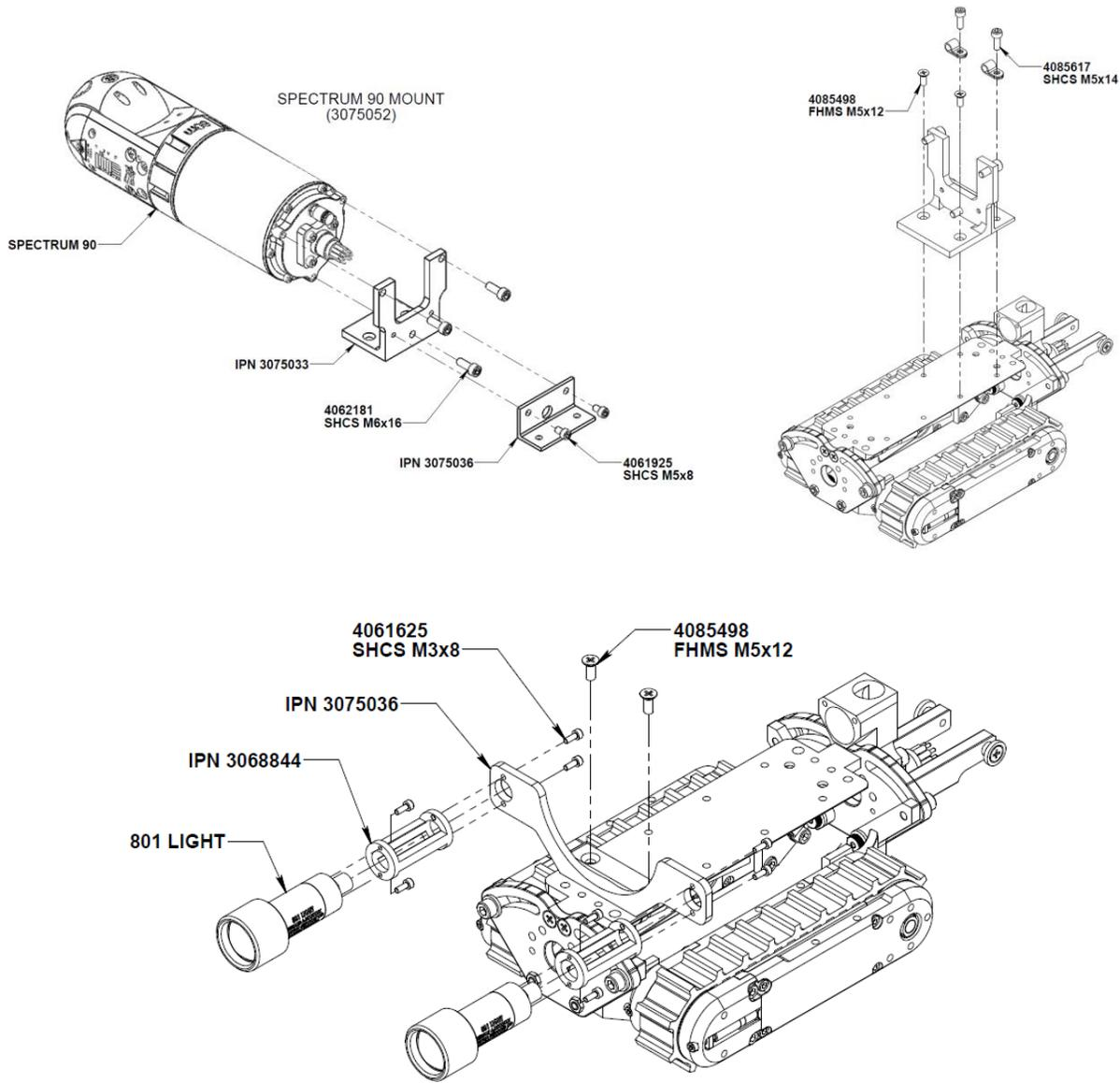

The vehicle chassis **does not** need to be disassembled to install the SP-90. Installation only requires a 5mm ball-end hex wrench, as shown.

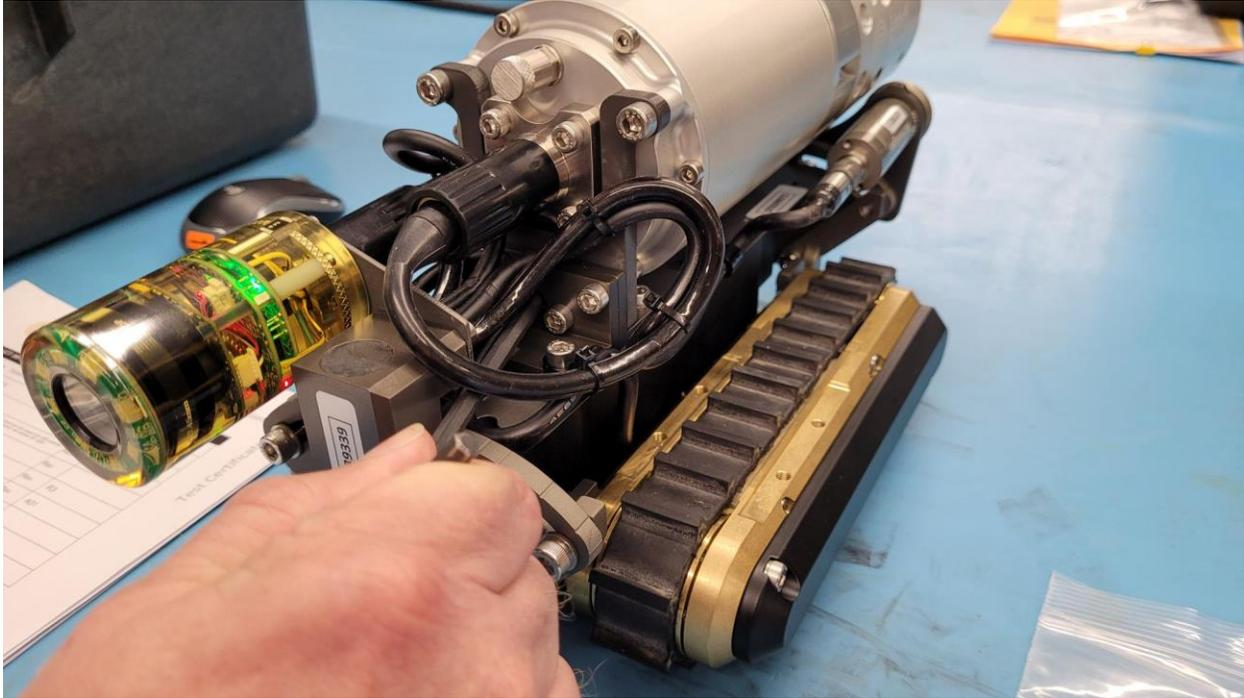

Document: UMDT013103.docm	Revision: A20	Created by: KJB	Date: 16 Oct 2023	3070984-A22
Source Location: C:\ePDM\ISLEng\products\dt-versatrax100mkii\manuals\UMDT013103.docm				Page 22 of 50

Track Mounting – Short Chassis

The tracks are removed or installed onto the vehicle using four M5 x 8 mm SHCS. The track whip connector must be fully mated (finger tight only), and the whip secured on place on the chassis using the provided P-clips.

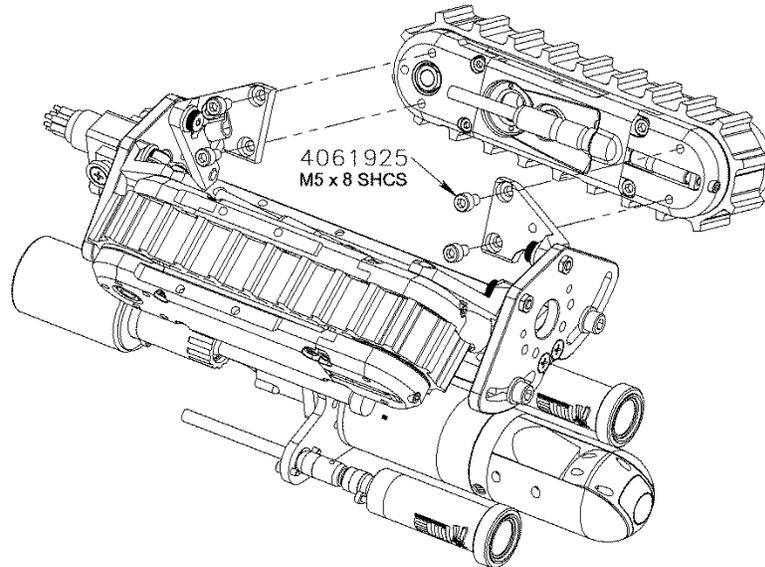

FIGURE 2: PARALLEL TRACK REMOVAL



WARNING: Track Voltage Input – Tracks are supplied in two different voltage ranges: 36-48VDC, and 30-70 VDC. Verify your tracks have the correct voltage input range for your system. 48V rated tracks will be damaged if connected to a 70-Volt system. Wide input tracks are designated by a **W** symbol on the side plate.

Traction Weight Kit

An optional weight kit may be added to the parallel vehicle to increase traction. The weight kit adds 3.9 kg (8.7 lb) to the VT-P205 vehicle. Standard weights are powder painted steel but can be requested in brass or stainless steel.

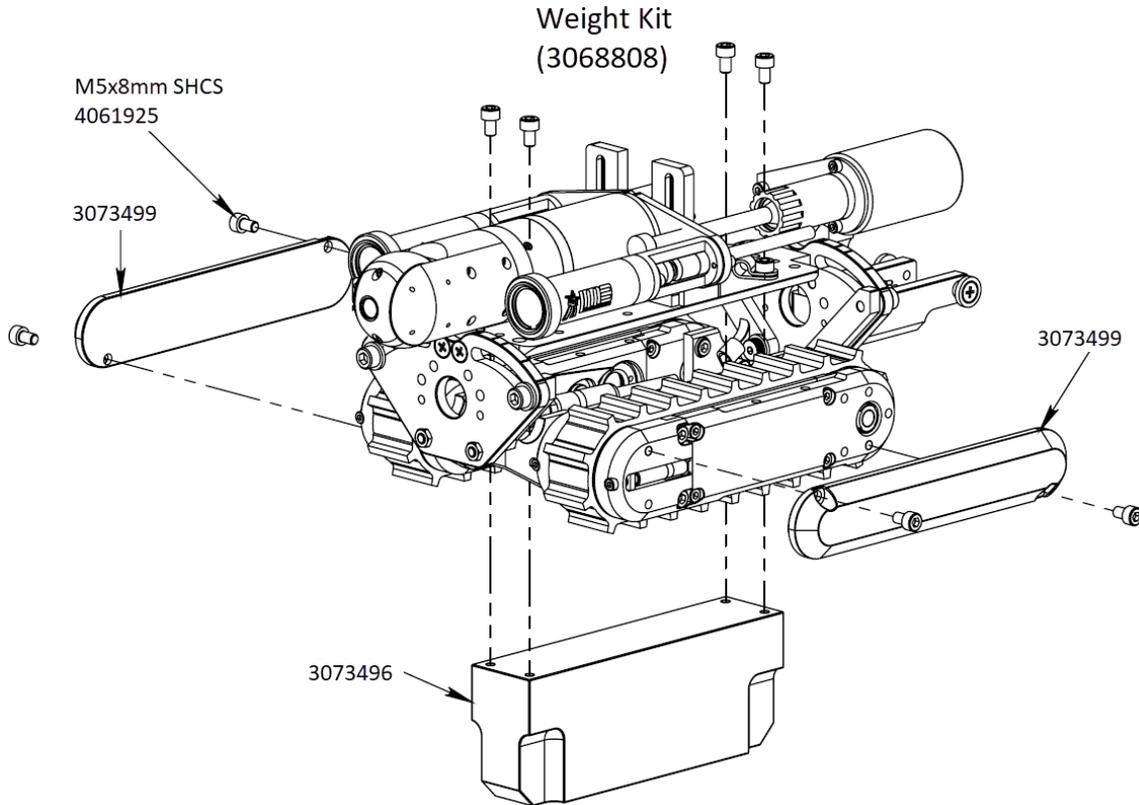

Magnet Kit

A magnetic attachment can be added to the VT-P205 for better traction in steel pipes and on steel surfaces. The magnet kit is not intended for vertical or inverted operation. The following subsections give detail on installation and adjustment of the magnet kit.

Note: Systems equipped with an SP90 require different fasteners for mounting the magnet tray. These systems are supplied with M6 x 30 mm, M6 x 25 mm, and M6 x 20 mm SHCS.

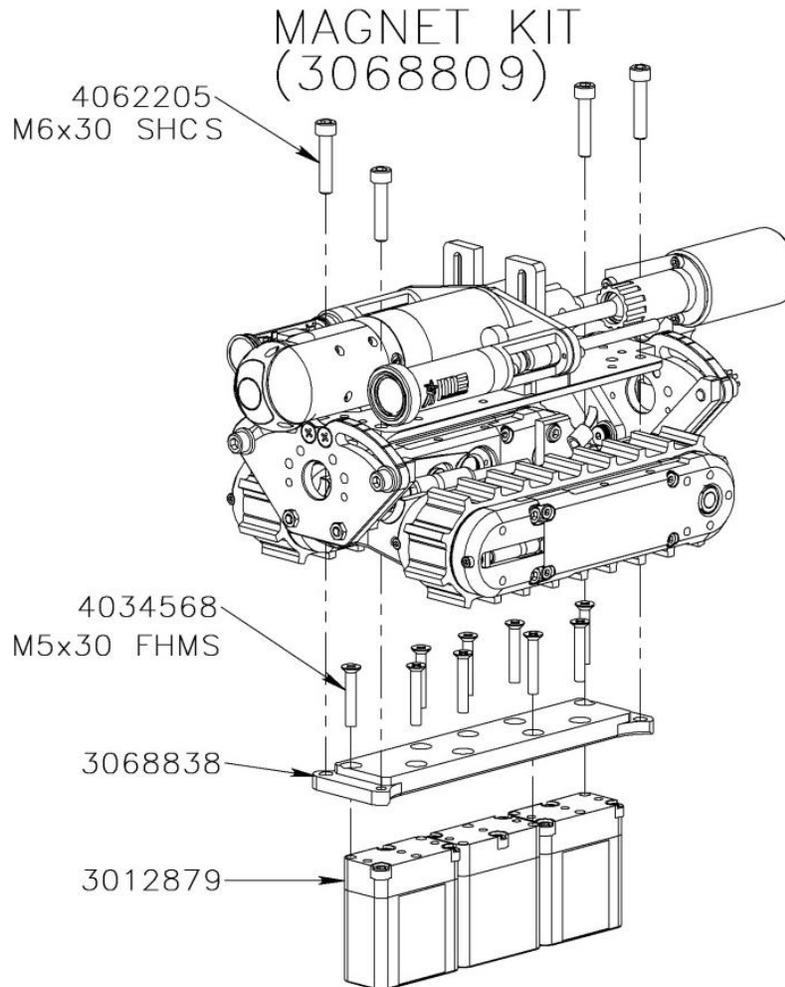

Magnet Kit Installation

To install the magnet kit, start with the vehicle in the flat configuration with the front camera whip disconnected, then, remove the harness by unscrewing the two M6 SHCS using a 5mm Allen key. Next, remove the four M5 FHMS that hold on the center bar by using a No. 1 Philipps screwdriver.

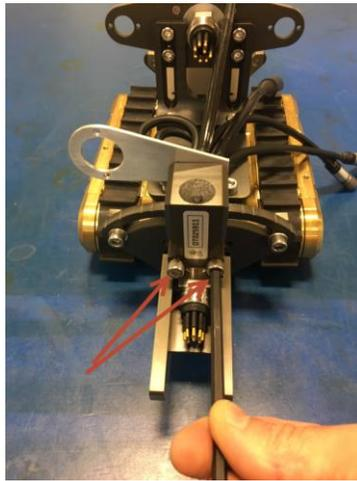

FIGURE 3: REMOVE HARNESS

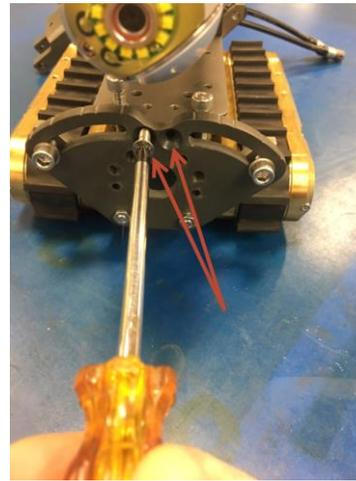

FIGURE 4: REMOVE CENTER BAR SCREWS

Finally, the center bar and camera mount can be lifted out of the chassis and the magnets installed to the center bar. **See Error! Reference source not found.** for assembly of the magnet plate and magnet boxes. Reassembly of the vehicle is the reverse of disassembly.



FIGURE 5: FRAME CENTER BAR REMOVAL

Document: UMDT013103.docm	Revision: A20	Created by: KJB	Date: 16 Oct 2023	3070984-A22
Source Location: C:\ePDM\ISLEng\products\dt-versatrax100mkii\manuals\UMDT013103.docm				Page 26 of 50

Magnet Adjustment

The magnet tray is held by four M6 screws. Two screws are pulling up, and two screws are pushing down in an “X” arrangement. The screws that are pushing down (lock screws) are threaded through the chassis backplane. The screws that are pulling up (height adjustment screws) are threaded through the magnet tray. Using this method, small adjustments can be made to the tilt angle of the magnet tray as well as the height. To adjust the magnet height, loosen off the two locking screws. Then adjust the height using the height adjustment screws as required. Last, evenly snug down the locking screws. These do not require much torque – the magnet tray may easily be distorted if the locking screws are too tight. If the locking screws are not positioned evenly, the magnet tray will be crooked. Use Loctite 243 (blue) to hold the screws in place. Use low torque.

When adjusting the magnet tray, it is important to set it to an appropriate height. The proper setting for magnet height is a balance of three factors: required force, required ground clearance, and track loading. Generally, the magnets should be set as close to the wall surface as possible to yield the highest pulling force. However, if the magnets are set too close, the vehicle may stick itself to the surface it is driving on or the additional load may overload the tracks and immobilize the vehicle.

In the case that the vehicle will be operated on a vertical surface, special care should be taken to set the magnet height. The inherently higher danger of operating the vehicle on a vertical surface necessitates a higher margin of safety for the magnetic adhesion of the vehicle. Also, discontinuities on the surface, such as welds, may cause the vehicle to lose magnetic adhesion; therefore, inspections should not require the vehicle to navigate over such discontinuities if it is operating vertically.

Note: If the system is equipped with an SP90, magnet tray mounting fasteners are to be replaced as required for clearance with the body of the camera. Longer fasteners are to be used when the magnet tray is adjusted to a lower position and shorter fasteners are to be used when the magnet tray is adjusted to a higher position.



Warning: Pinch Hazard – Rare earth magnets are very strong. Use caution when handling the magnets or vehicle near steel objects, they may snap together unexpectedly.



Warning: Strong Magnets – Operators with magnetically sensitive medical implants should be aware and follow appropriate practices. Care should also be exercised around other magnetically sensitive devices, including computer hard drives, cell phones, watches and credit cards.

Document: UMDT013103.docm	Revision: A20	Created by: KJB	Date: 16 Oct 2023	3070984-A22
Source Location: C:\ePDM\ISLEng\products\dt-versatrax100mkii\manuals\UMDT013103.docm				Page 27 of 50

VT-P205 Extended Chassis

The extended VT-P205 uses extended Tracks to accommodate the Spectrum™ 90 camera with best stability. Weight and magnet kits are available for the chassis as described below. In addition to the Spectrum™ 90, the extended chassis will accommodate the Spectrum™ 45 camera using the same mounting hardware as the short chassis.

Track Angle Adjustment

The VT-P205 track angle may be continually adjusted from FLAT to 200 mm (8 in) ID pipe. To change the track angle, loosen the four M6 socket cap screws located in the end plate slots, move the track to its new angle, and retighten the screw. Indicator marks have been placed on the end plates for 200, 250, 300, and 600 mm (8, 10, 12, and 24 in) and FLAT configurations.

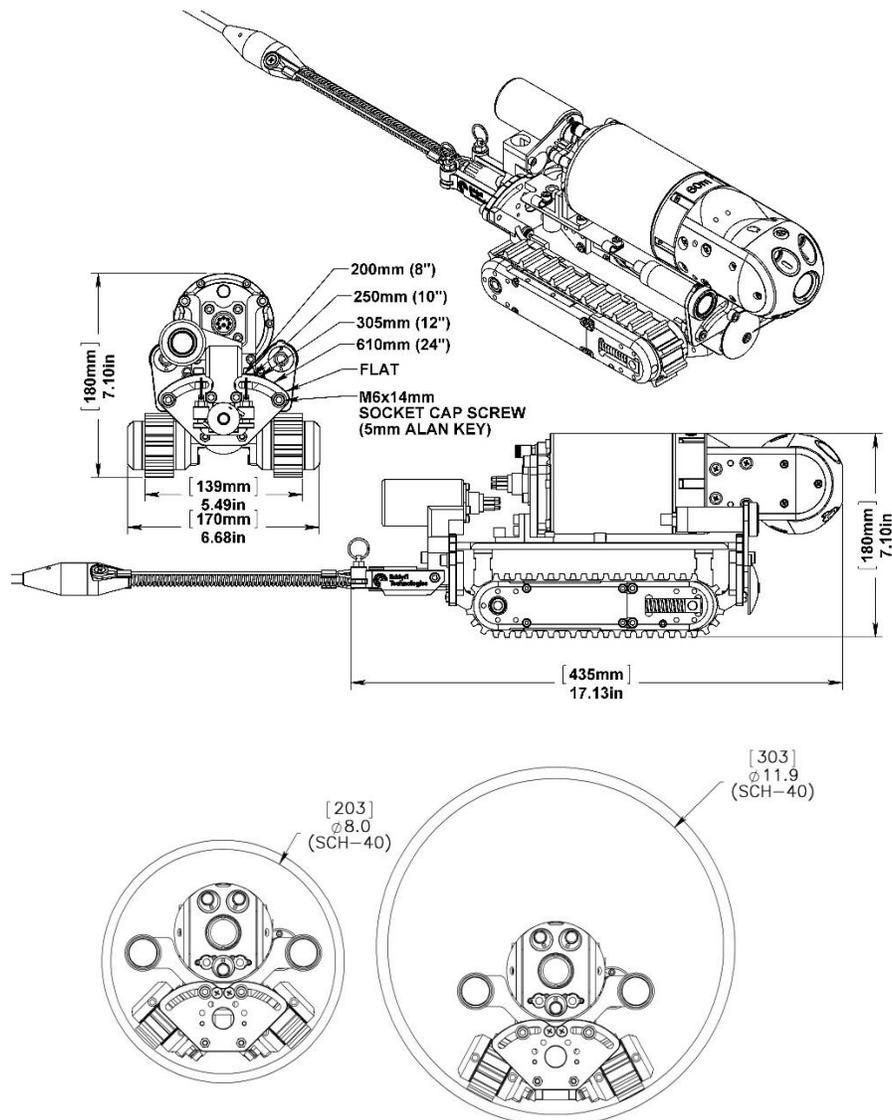

Document: UMDT013103.docm	Revision: A20	Created by: KJB	Date: 16 Oct 2023	3070984-A22
Source Location: C:\ePDM\ISLEng\products\dt-versatrax100mkii\manuals\UMDT013103.docm				Page 28 of 50

Spectrum™ 90 and 801 Light Installation

The front SP90 camera is mounted to the vehicle using M6 x 16 mm SHCS. The camera is oriented with the Schrader valve on the back of the camera facing up. Additional lighting is provided by the two 801 Lights, installed into the front mounting frame using a set screw. The rear facing camera uses an extended mount (from the factory) to prevent cabling interference with the Spectrum™ 90 camera. Use Loctite 243 (blue) with all fasteners. Use Loctite 243 (blue) with all fasteners. The Camera can be mounted without having to disassemble the chassis; a 5mm ball-end hex wrench can be used to install the camera easily.

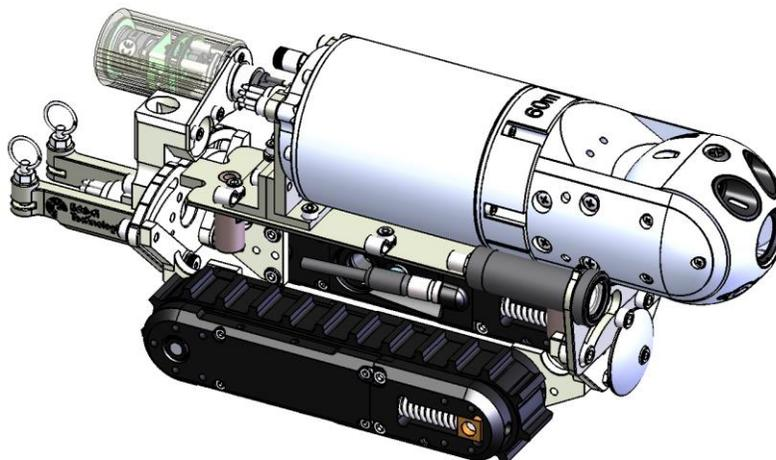
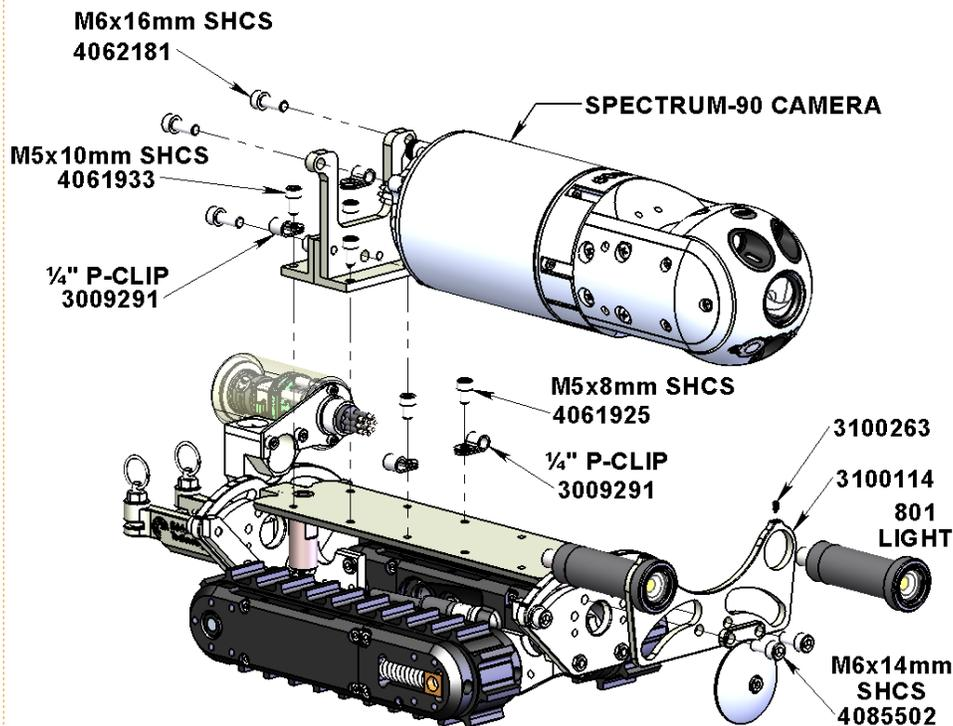

Document: UMDT013103.docm	Revision: A20	Created by: KJB	Date: 16 Oct 2023	3070984-A22
Source Location: C:\ePDM\ISLEng\products\dt-versatrax100mkii\manuals\UMDT013103.docm				Page 29 of 50

Spectrum™ 45 Mount

The mounting hardware and method for the Spectrum™ 45 onto the extended chassis is identical to that used for the short chassis. The camera height adjustments and 801 light mounting are the same. The Spectrum™ 45 camera extension kit 3069627 may also be used with the extended chassis. Refer to the instructions under “VT-P205 Short Chassis.”

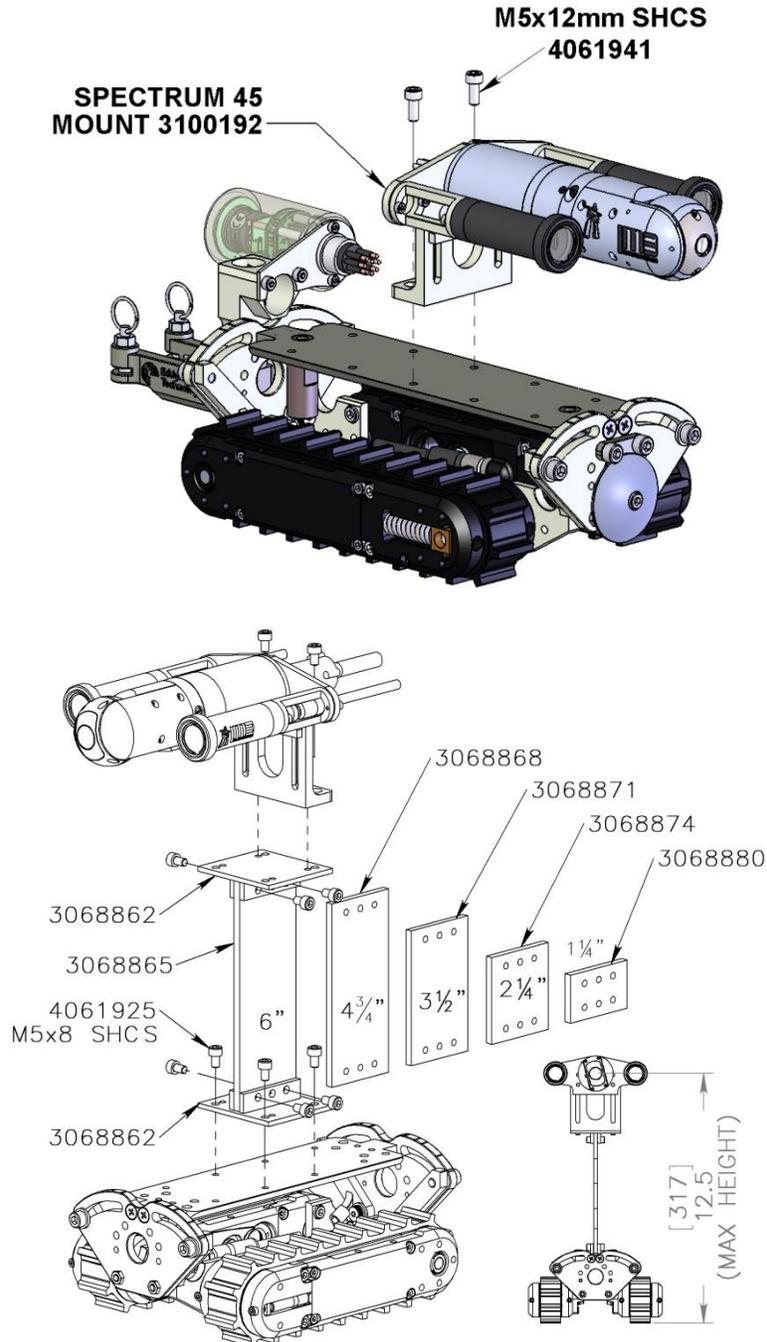

Document: UMDT013103.docm	Revision: A20	Created by: KJB	Date: 16 Oct 2023	3070984-A22
Source Location: C:\ePDM\ISLEng\products\dt-versatrax100mkii\manuals\UMDT013103.docm				Page 30 of 50

Track Mounting – Extended Chassis

The tracks are removed or installed onto the vehicle using four M5 x 8 mm SHCS (4061925). The track whip connector must be fully mated (finger tight only), and the whip secured on place on the chassis using the provided P-clips.

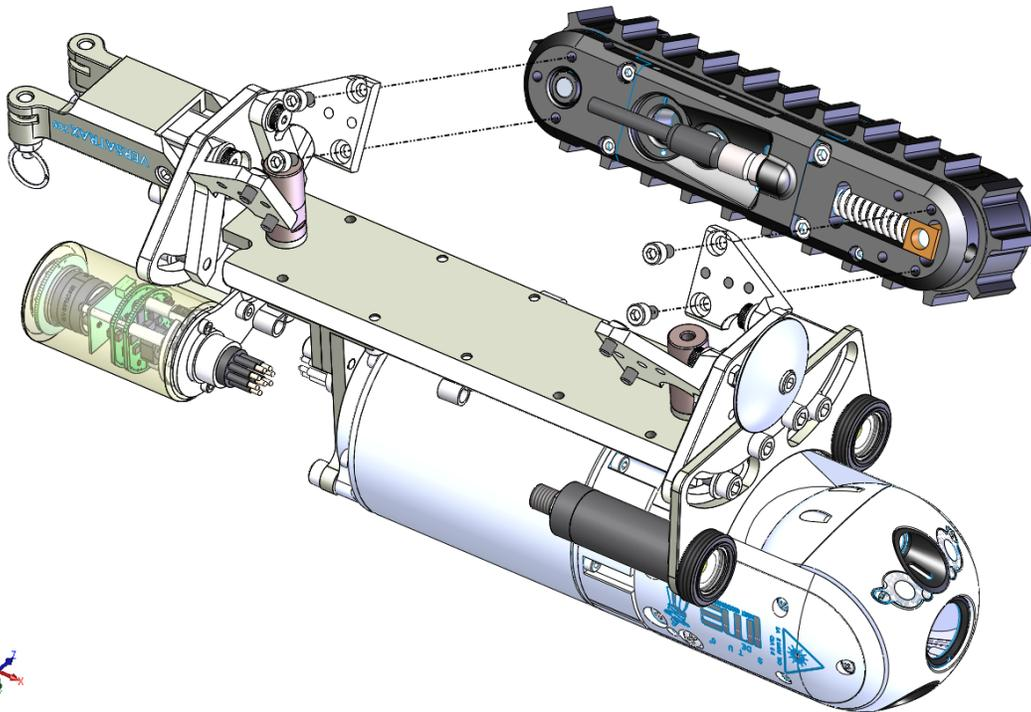

Extended Traction Weight Kit

An optional weight kit may be added to the extended VT-P205 vehicle to increase traction. The weight kit adds 4.2 kg (9.2 lb) of downforce to the vehicle. Standard weights are painted steel but can also be requested in brass or stainless steel.

Install the bottom weight onto the permanent mounting stems at each end of the chassis as shown below using M6 flat washers and M6x16mm socket head cap screws.

The side weights attach directly to the tracks using M5x8mm socket head cap screws. Use Loctite 243 (blue) with all fasteners.

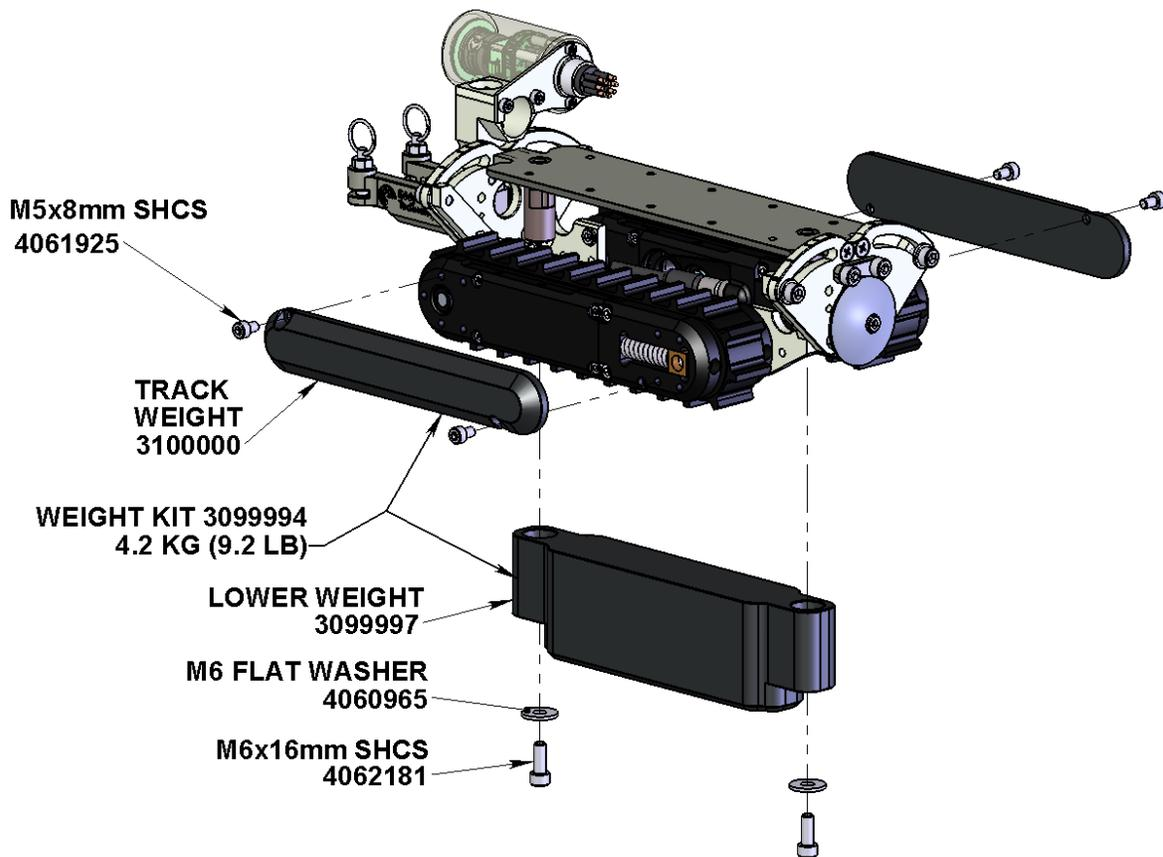

Document: UMDT013103.docm	Revision: A20	Created by: KJB	Date: 16 Oct 2023	3070984-A22
Source Location: C:\ePDM\ISLEng\products\dt-versatrax100mkii\manuals\UMDT013103.docm				Page 32 of 50

Extended Magnet Kit

A Three-Cup magnetic attachment can be added to the extended VT-P205 chassis for better traction in steel pipes and on steel surfaces. An additional downforce of 27 kg (60 lb) can generally be achieved.

Warning: The magnet kit is not intended for vertical or inverted operation. The magnet kit is intended to provide downforce only. There are insufficient magnets for reliable vertical or inverted use. Damage from falling will result.

Note: It is acceptable to use the magnet kit for traction on steep inclines where falling is not a risk.

To install and adjust the magnet tray:

1. The adjustment stems on each end of the magnet tray contain captured screws which are turned using 4mm Alan key. Screw these evenly into the permanent mounting stems at each end of the chassis as shown below.
2. The magnet tray may be adjusted up or down as needed for the curvature of surface at hand. For best performance and clearance, we recommend a 5-6mm (0.20 – 0.23 inch) gap between the magnet and the metal surface.

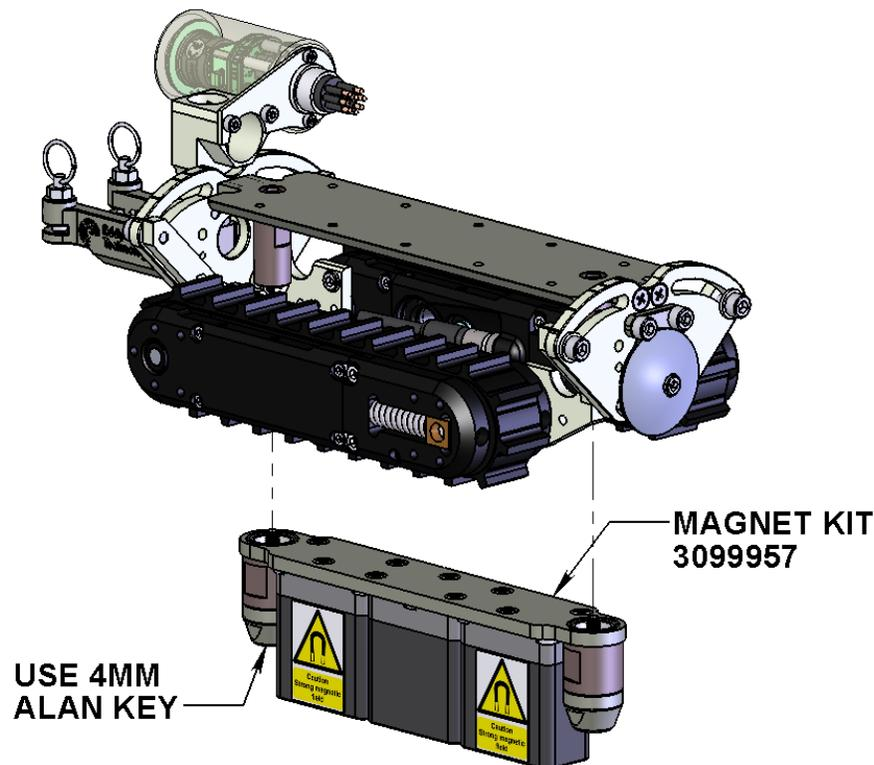

Document: UMDT013103.docm	Revision: A20	Created by: KJB	Date: 16 Oct 2023	3070984-A22
Source Location: C:\ePDM\ISLEng\products\dt-versatrax100mkii\manuals\UMDT013103.docm				Page 33 of 50

VT-I100
Track Installation

The VT-I100 vehicle uses two sets of side plates and two sets of “X” hinges to connect the tracks. To begin assembly of the inline configuration, gather the wiring harness, side plates, tracks, hinges, and screws. Line up the hinges and tracks as illustrated below. Note that the wiring harness remains strapped to the hinges. When disassembling the vehicle there is no need to remove the wiring from the hinges.

1. Connect the track electrical connectors. Both tracks are placed with the connectors on their right-hand side.
2. The hinges connect to the side plates, then the side plates to the tracks. First assemble the side plates into position with the hinge pivot pins sliding into the plate pivot holes. Then screw the side plates onto the tracks using M5 x 8 mm SHCS. Use Loctite 243 (blue) on all screws.

The vehicle is now ready to configure for the target pipe size.

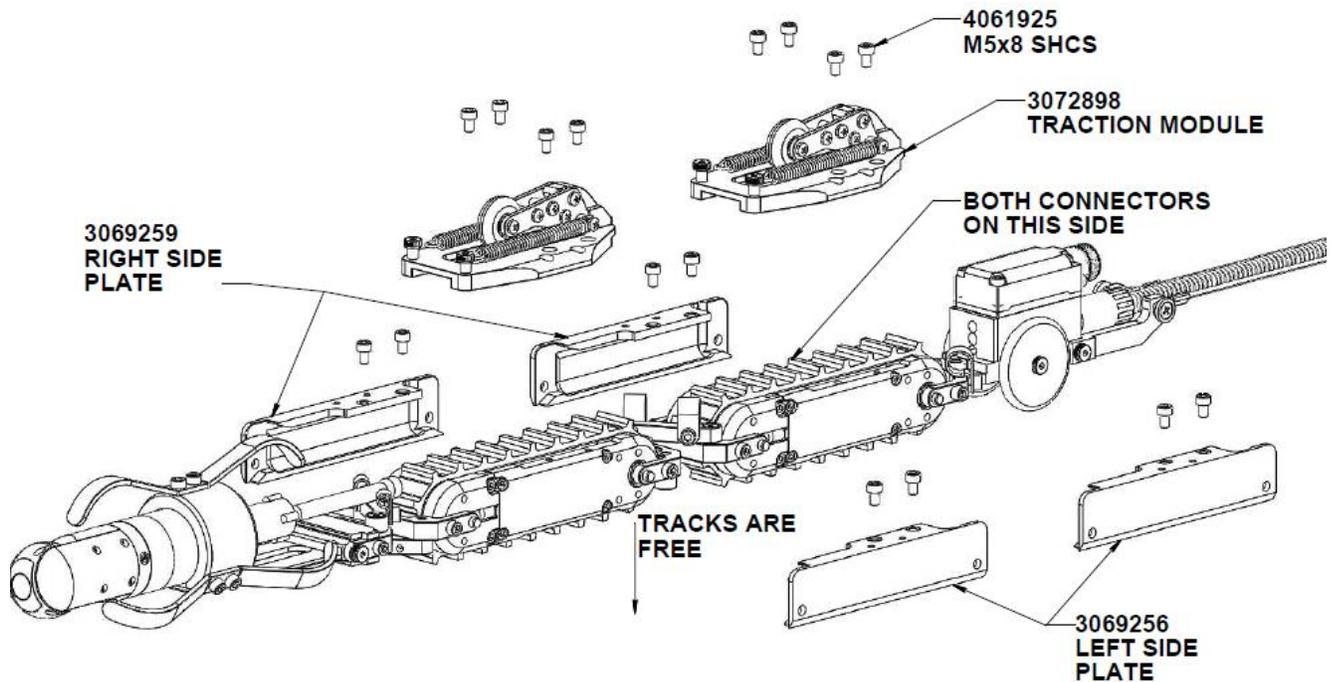

Document: UMDT013103.docm	Revision: A20	Created by: KJB	Date: 16 Oct 2023	3070984-A22
Source Location: C:\ePDM\ISLEng\products\dt-versatrax100mkii\manuals\UMDT013103.docm				Page 34 of 50

100 mm (4 in) Configuration

1. The 100 mm (4 in) vehicle configuration uses the spring-loaded traction units (illustrated above) without spacers.
2. Install the 100 mm (4 in) skids around the camera (illustrated below). Use Loctite 243 (blue) with all fasteners.

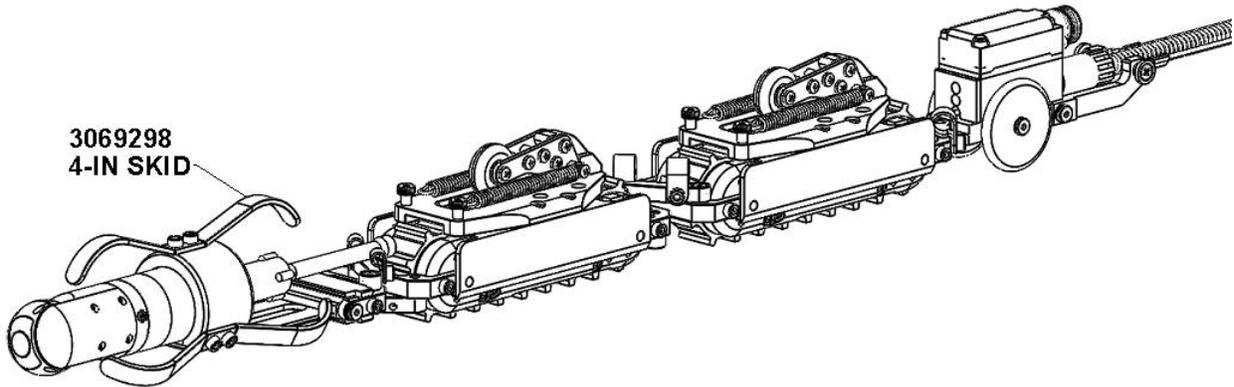

125 mm (5 in) Configuration

1. The 125 mm (5 in) vehicle configuration uses the spring-loaded traction units (illustrated above) with one spacer.
2. Install the 125 mm (5 in) skids around the camera (illustrated below). Use Loctite 243 (blue) with all fasteners.

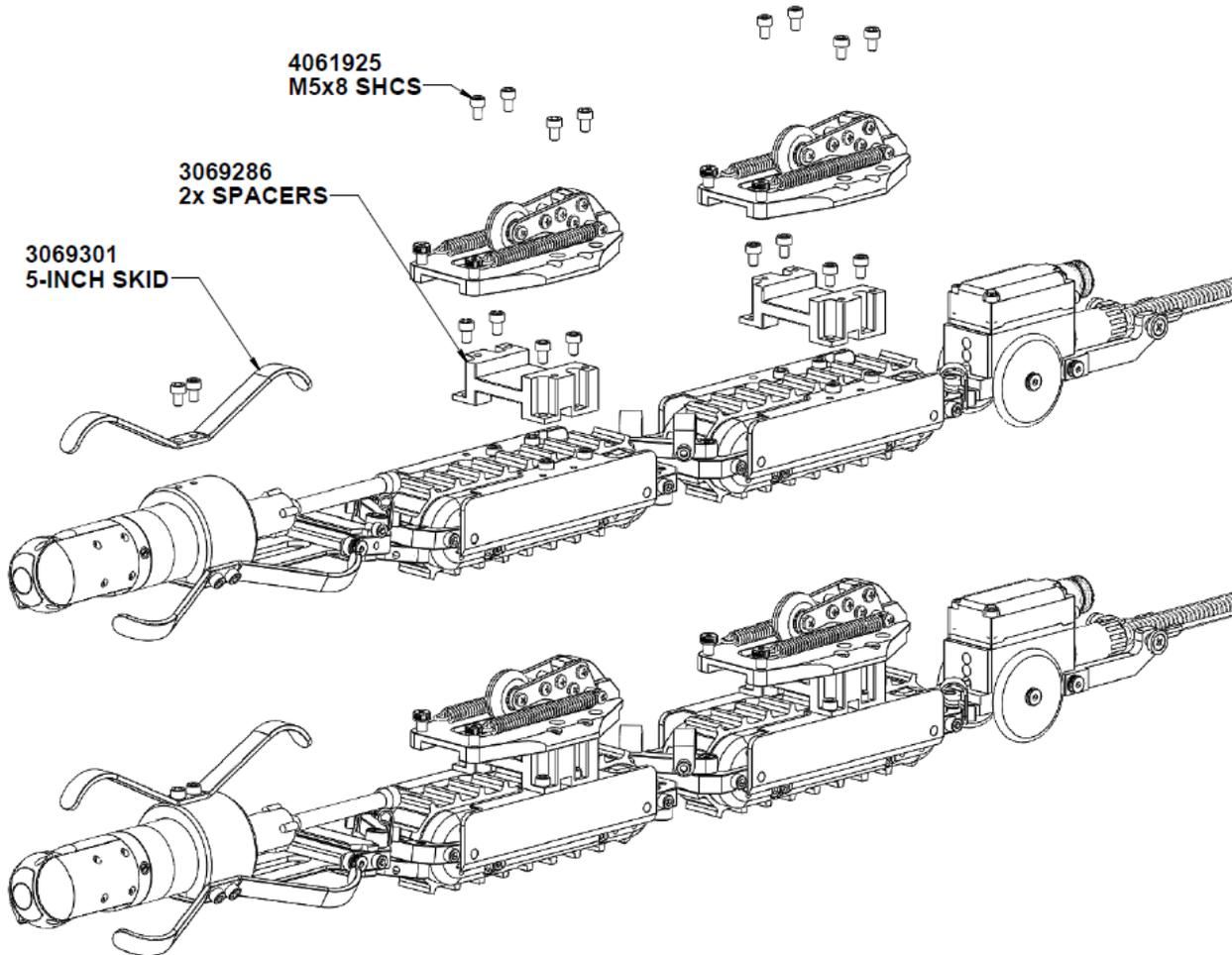

150 mm (6 in) Configuration

1. The 150 mm (6 in) vehicle configuration uses the spring-loaded traction units (illustrated above) with two spacers.
2. Install the 150 mm (6 in) skids around the camera (illustrated below). Use Loctite 243 (blue) with all fasteners.

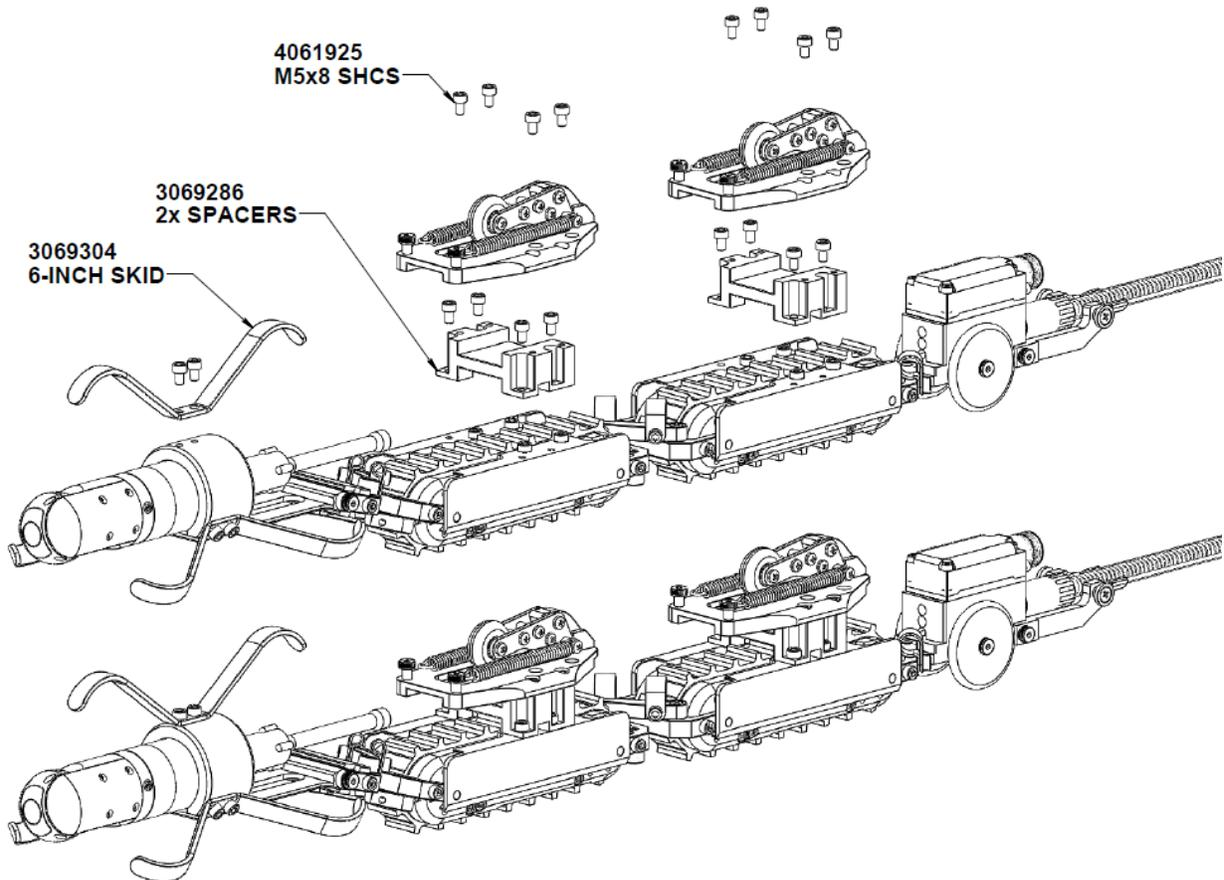

Document: UMDT013103.docm	Revision: A20	Created by: KJB	Date: 16 Oct 2023	3070984-A22
Source Location: C:\ePDM\ISLEng\products\dt-versatrax100mkii\manuals\UMDT013103.docm				Page 37 of 50

Rear Camera

An optional rear camera may be installed on the VT-I100.

No camera: Install the blank plate as shown below. The wired camera connector will be stowed in the counter-bored hole under the lid.



IMPORTANT: When reinstalling the camera or blanking plate, always inspect the O-ring and replace if damaged. Grease the O-ring with Molykote 111 before installation.

Rear camera: Remove the blank plate. Plug the camera connector wiring into the rear camera module. Screw the module in place, ensuring the O-ring is clean and fully seated in its groove. Camera modules come aligned from the factory. If further adjustment is required to level the image, slightly loosen the two screws holding on the camera lens and rotate until the image is level.

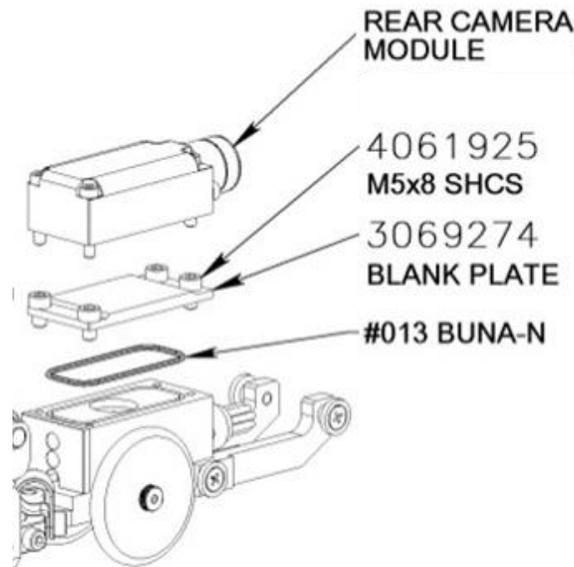

Front Sapphire™ Camera

The VT-I100 can be configured with a Sapphire as its front camera. This requires a non-standard harness.

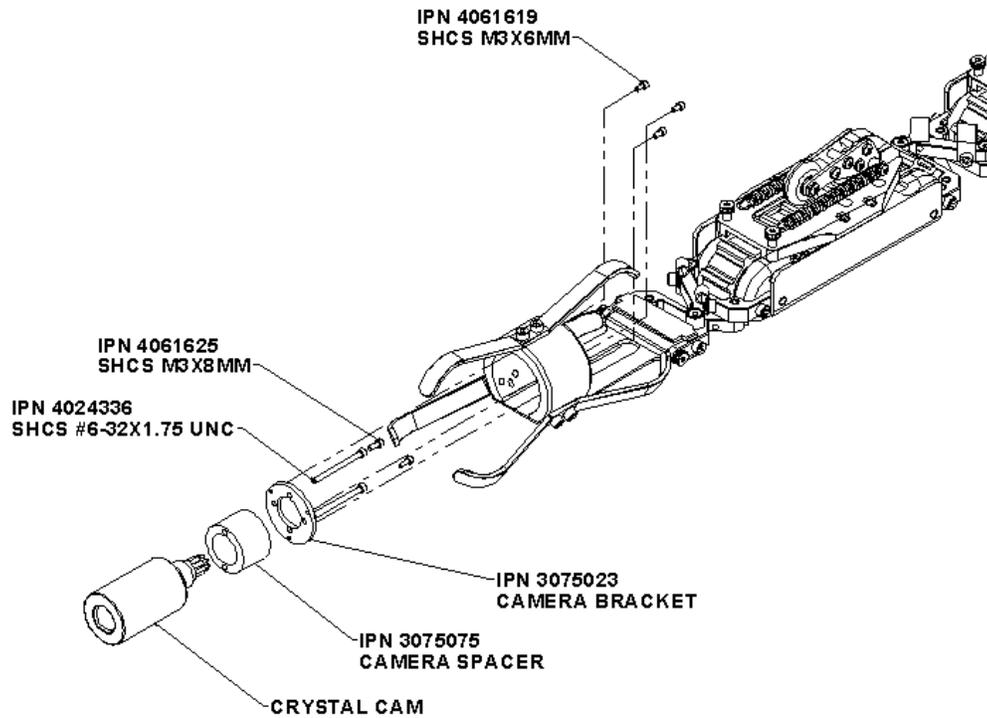

Operation

Pre-Operations Check

Before each deployment of the VT-I100 or VT-P205 systems, ensure everything is completed on the following checklist.

- Check that the work area has been safely set up.
- Fall arrest is in place for vertical or inverted use.
- Check that the line voltage available at the worksite matches the equipment setup.
- Check that power and deck cable connections are correct.
- Check the vehicle for the following:
 - Verify the vehicle is in the correct configuration for the deployment.
 - Check the vehicle for mechanical damage to the chassis or cable harnesses which could affect its operation.
 - Ensure that all fasteners are in place and secure. In particular, check the fasteners holding on cameras, lights, tracks, and the harness block.
 - Visually inspect the vehicle and Tracks to ensure that the moving parts are free of debris and functional. Make sure the track belt is free of debris and turns freely.
 - Check the tether and vehicle whips for damage.
 - Ensure camera, light, and laser ports are clean.
- Check the reel for the following:
 - Check that nothing will block movement of the level wind shuttle.
 - Check that the tether has no loose, dangling coils. Dangling coils can propagate as the drum rotates and have the potential to jump the drum. Take care of these before deploying the tether.
- Power up the system and check the following:
 - Check for sufficient SSD drive space for recording.
 - Check record directories are set.
 - Test video recording.
 - Test laser lines
 - Test auxiliary lights.
 - Test track control.
 - Test camera control.

Document: UMDT013103.docm	Revision: A20	Created by: KJB	Date: 16 Oct 2023	3070984-A22
Source Location: C:\ePDM\ISLEng\products\dt-versatrax100mkii\manuals\UMDT013103.docm				Page 40 of 50

Post-Operations Check

A Post-Ops inspection should be carried out after every deployment using the following checklist:

- Inspect the tether for damage as it is reeled in.
- Visually inspect vehicle for entrained debris or mechanical damage.
- Test each function to ensure proper operation.
- Clean the system by hosing it down with water at regular line pressure. Do not pressure wash. The tracks may be cleaned off by hosing them down while running. If the system has been used in salt water, thoroughly rinse the vehicle with fresh water right away.



CAUTION: Do not use a pressure washer to clean the camera. Very high-pressure water can push past seals and flood the camera resulting in electrical damage or personal injuries.

- Take time to pack the system properly for transport away from the worksite.
- Store the system in a dry environment.

Note: Ensuring the VT-I100 or VT-P205 system is always stored in good working condition will minimize deployment time for future inspections.

Document: UMDT013103.docm	Revision: A20	Created by: KJB	Date: 16 Oct 2023	3070984-A22
Source Location: C:\ePDM\ISLEng\products\dt-versatrax100mkii\manuals\UMDT013103.docm				Page 41 of 50

ICON™ Software

Vehicle control, video recording and export are accomplished using ICON graphical interface controller software. The manual for ICON is integrated into the software or available in PDF format on the control computer's desktop.

- ICON Manual – Accessed through ICON or Desktop Shortcut.

Dealing with Obstacles

The operator will invariably encounter a range of obstacles in a pipe. Each time the operator must decide if the vehicle can safely pass or if there is risk of getting stuck. Common obstacles include but are not limited to:

- Crushed pipe
- Corrosion
- Sand
- Rocks, construction debris, random rubbish
- Roots
- Intersecting service pipes
- Wildlife and nests

The VT-P205 vehicle naturally straddles the debris at the very bottom of a pipe. If the debris is high, you may try installing the track extension brackets to give the chassis more clearance. Additionally, the inside track weights may be removed to increase center clearance.

If the operator is unsure about pipe navigability, he or she should consult with the site supervisor before moving forward.

Troubleshooting

Camera Control Problems

- Not all the auxiliary lights are on.
 - The ICON software allows the lights to be controlled independently. Ensure all lights are enabled. Refer to the ICON interface manual.
 - Inspect for blown LEDs.
- Warning: High Intensity. Do not look directly into the lights. Use a welding filter (shade #8) to observe the light elements.
- Camera pan or tilt does not function in one or both directions.
 - Check that the camera is not jammed.
 - If you can hear a motor running but see no movement, there is a mechanical or clutch problem inside the camera. Contact us.
- Camera is moving very slowly.
 - Check the pan & tilt speed in the camera control window. Refer to the ICON user interface manual.

Document: UMDT013103.docm	Revision: A20	Created by: KJB	Date: 16 Oct 2023	3070984-A22
Source Location: C:\ePDM\ISLEng\products\dt-versatrax100mkii\manuals\UMDT013103.docm				Page 42 of 50

Video Problems

- No video (black or blue background)
 - Interface box is not turned on.
 - Video cables are not hooked up between interface box and computer.
 - Camera connector on vehicle is loose (turn power off first before plugging in camera).
 - Check that the camera harness whip is plugged into the correct socket on the telemetry can.
 - Check monitor input settings.
- Vehicle power is not on.
 - Check for problems with other video components between the computer and monitor.
 - Try a different monitor. Whole days have been spent on field maintenance trips only to discover a faulty monitor.
- Picture is very dark or very bright.
 - Check the light levels of both the camera and main lights.
- Intermittent picture.
 - Check and replace the video cables.
 - Check the monitor is working properly.
 - Check that the camera harness whip is fully plugged in.
 - Check for intermittent breaks in the camera harness cable.
 - Check the tether connectors at both controller and vehicle.
 - Check for tether or slip ring damage by testing tether continuity.
- Picture is blurry, will not focus, or has poor color.
 - This may be a dirty camera view port, or a narrow object lying in front of the view port.
 - Object may be too close to the camera.
- No Rear Video
 - Verify the video connection from the interface box to the computer.
 - This may be a dirty camera view port, or a narrow object lying in front of the view port.

Vehicle Problems

- Vehicle won't steer or vehicle runs backward.
 - Tracks set to the wrong positions.
 - Track reverse setting incorrect in control software.
 - Node ID conflict between one or more devices on the vehicle.
- Tracks will not run.
 - Check the track current feedback (See ICON manual).
 - If current is at 100% and the vehicle doesn't move, then the tracks may be jammed. They could be wedged on an object or jammed with sand. Try reversing the tracks to clear debris. If a jam won't clear, you will have to recover the vehicle by pulling it out with the tether.
 - If no current registers, then power or communication is not getting to the tracks. Check all the cable connections.
 - Try power cycling the system.
 - Inspect the vehicle wiring for damage.

Document: UMDT013103.docm	Revision: A20	Created by: KJB	Date: 16 Oct 2023	3070984-A22
Source Location: C:\ePDM\ISLEng\products\dt-versatrax100mkii\manuals\UMDT013103.docm				Page 43 of 50

- Check all the system connectors.
- Try restarting ICON™
- Listen for the track motors. If the motors run but the track doesn't turn, there is a problem with the gearing or shaft pins.
- Try changing tracks. (ICON will require a restart.)
- Track Raise will not move.
 - Check the linkage between the top linkage and the encoder feedback.
 - Check the connector to the camera raise motor.
 - Try restarting ICON.

Reel Problems

- Tether distance does not read correctly.
 - Check that the pressure wheel is pressing the tether against the payout sheave. If the tether is being pulled up from the sheave instead of down, it may be disengaged from the sheave.
 - Check that the units are set properly in the graphical overlay.
 - Recalibrate distance encoder.
 - Ensure that the correct COM port is selected in the control software.

Document: UMDT013103.docm	Revision: A20	Created by: KJB	Date: 16 Oct 2023	3070984-A22
Source Location: C:\ePDM\ISLEng\products\dt-versatrax100mkii\manuals\UMDT013103.docm				Page 44 of 50

Maintenance

Galvanic Corrosion Control

Eddyfi Technologies strongly recommends cathodic protection whenever the VT-I100 or VT-P205 is being deployed in a saltwater environment – either submerged or in salt spray, regardless of camera or track material.

Eddyfi Technologies' vehicles are designed to use **aluminum** marine anodes. Aluminum anodes are common in the marine industry and are replacing zinc anodes in many areas. For vehicle systems that are often pulled in and out of the water, aluminum anodes are especially important, as zinc anodes tend to scale over when exposed to air and may not reactivate when submerged again. An aluminum anode will always reactivate.

If the vehicle is being carried by a transport device, for example, a larger ROV, we recommend it also be protected by **aluminum** anodes or the two vehicles be electrically isolated from one another. Do not mix anode types (zinc and aluminum) on the assembly, between vehicles or between structures. There must be only one anode type throughout. Magnesium anodes must never be used with Eddyfi Technologies equipment.

Anodes are installed onto the VT-I100 or VT-P205 as illustrated below and secured with Loctite 243. Contact your sales representative for anode replacements.

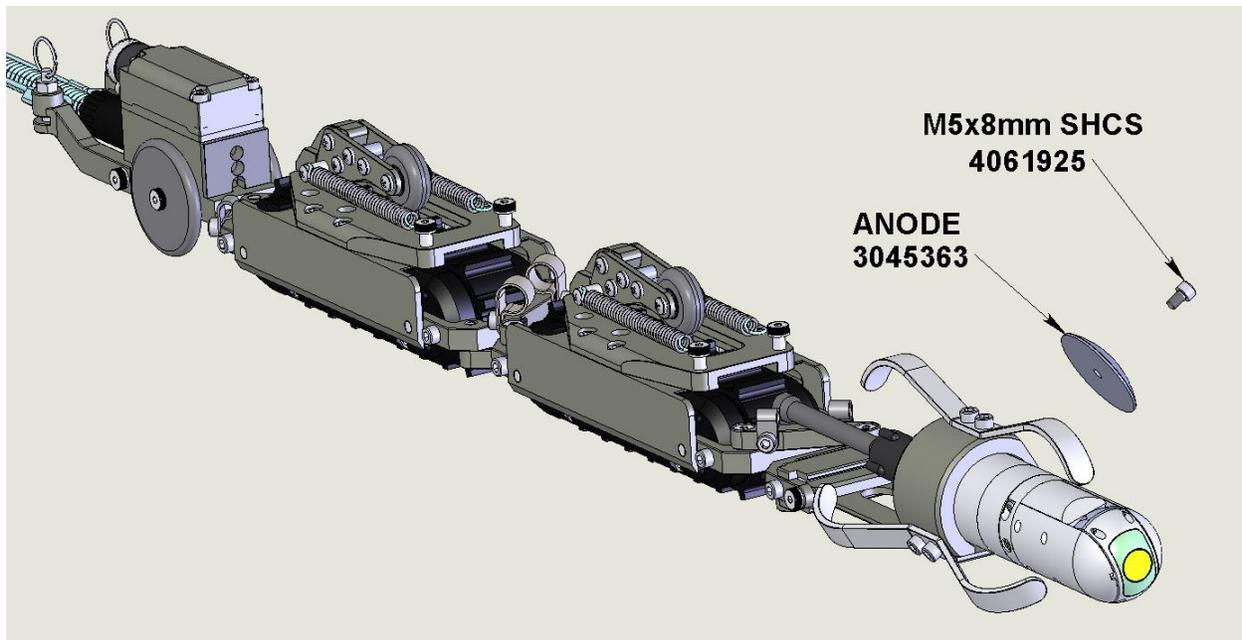

Document: UMDT013103.docm	Revision: A20	Created by: KJB	Date: 16 Oct 2023	3070984-A22
Source Location: C:\ePDM\ISLEng\products\dt-versatrax100mkii\manuals\UMDT013103.docm				Page 45 of 50

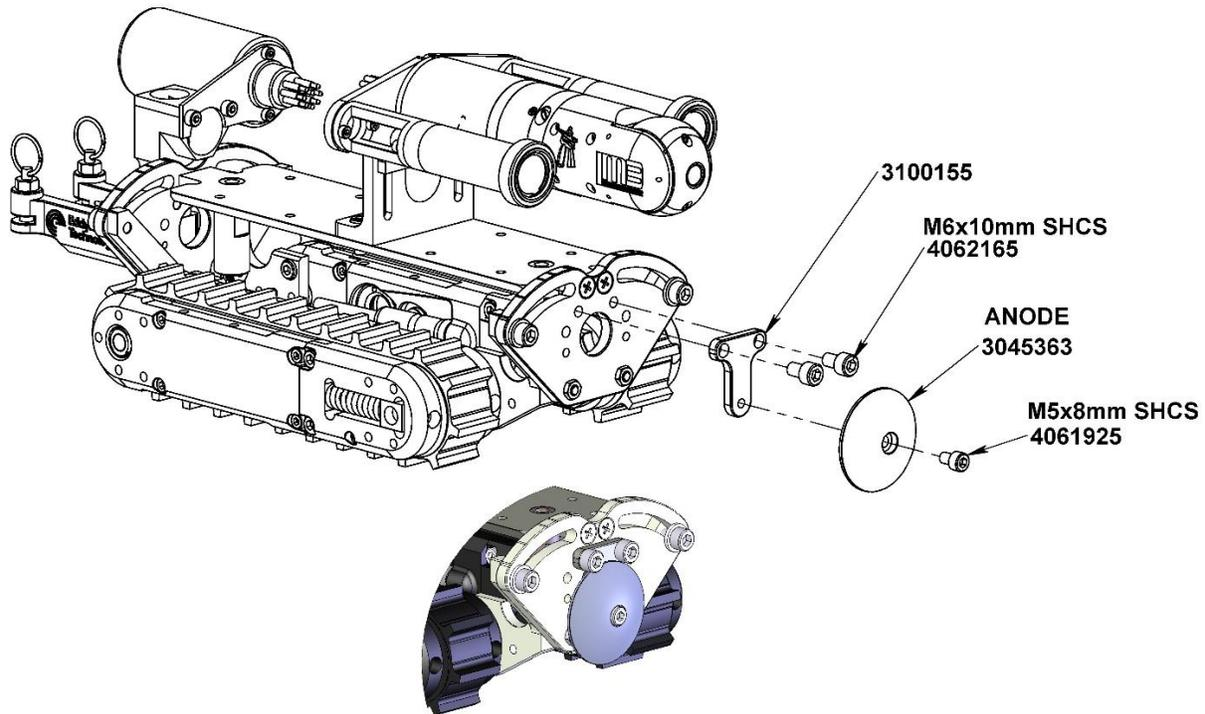

Rinsing and Cleaning

After every mission check to see if the vehicle needs cleaning.

1. If the system has been used in salt water, thoroughly rinse the vehicle with fresh water prior to being stored away. Accelerated corrosion will result if the inspection system is not rinsed properly. Pay close attention to rinsing and cleaning the camera window, LED light dome and the spaces between moving parts and track belts.
2. Use an open hose or tap at regular water line pressure for rinsing. Do not pressure wash the equipment – water will be forced into the camera at these high pressures.
3. Avoid scratching the camera port. Use glass cleaner and a soft cloth to clean the port.



CAUTION: Do not use a pressure washer to clean the camera. Very high-pressure water can push past seals and flood the components resulting in electrical damage or personal injuries.

Periodically:

1. Use a damp cloth or spray cleaner for the power supply / controller box. The box must never be sprayed down or immersed in water. Unplug the controller before cleaning.
2. For general cleaning of the cameras and tracks, use a mild detergent.

Document: UMDT013103.docm	Revision: A20	Created by: KJB	Date: 16 Oct 2023	3070984-A22
Source Location: C:\ePDM\ISLEng\products\dt-versatrax100mkii\manuals\UMDT013103.docm				Page 46 of 50

Fuse Replacement

The controller and power supply contain panel mount fuses for both AC and DC voltages. These fuses are for the safety of the operator(s) as well as to protect the equipment from damage. If a fuse blows, stop and look for possible causes. Causes might include cable damage, water incursion or improper connections. *See the controller manual for fuse replacement.*

Fuse values have been carefully selected for their application. Always replace the fuses with the same type and rating.



Caution: Disconnect the power source before checking or replacing fuses.

Track Maintenance

Refer to the Track manual for maintenance and servicing instructions.

Camera Maintenance

Refer to the Spectrum™ 45 or Spectrum™ 90 manual for camera maintenance and servicing instructions.

Tether Re-termination

Contact us if tether re-termination is required. Tether re-termination kits are also available. Detailed instructions and wiring diagrams will be included with the kit.

Document: UMDT013103.docm	Revision: A20	Created by: KJB	Date: 16 Oct 2023	3070984-A22
Source Location: C:\ePDM\ISLEng\products\dt-versatrax100mkii\manuals\UMDT013103.docm				Page 48 of 50

Parts and Repairs

Ordering Parts/Customer Service

Spare and/or replacement parts are available for your product and can be ordered directly from your local office.

When ordering parts always make sure to quote the sales order acknowledgement (SOA) number and/or the serial number of the system component in question.

Eddyfi Robotics Inc. (Canadian Headquarters and Manufacturing Location)

2569 Kenworth Road, Suite C

Nanaimo, BC, V9T 3M4

CANADA

TF 1.877.468.5886

T +1.250.729.8080

info@eddyfi.com

www.eddyfitechnologies.com

Eddyfi Technologies – US (American Authorized Distributor and Service Centre)

812 W 13th Street

Deer Park, TX, 77536

USA

T +1.281.542.3292

info@eddyfi.com

www.eddyfitechnologies.com

Document: UMDT013103.docm	Revision: A20	Created by: KJB	Date: 16 Oct 2023	3070984-A22
Source Location: C:\ePDM\ISLEng\products\dt-versatrax100mkii\manuals\UMDT013103.docm				Page 49 of 50

Warranty Repairs

Warranty conditions are specified in the Warranty section. Should any conditions of the manufacturer's warranty be breached, the warranty may be considered void. All returned items must be sent prepaid to Eddyfi Technologies at the above address.

Factory Returns to Canada

Some sub-assemblies of your Eddyfi Technologies product are not field-serviceable and may need to return to the factory for repair. Warranty claims must return to the factory for evaluation.

To return an item for evaluation or repair, first contact Eddyfi Technologies at our toll-free number or e-mail address. Eddyfi Technologies will supply a Return Merchandise Authorization (RMA) number with detailed shipping and customs instructions. Items shipped without an RMA number will be held at Eddyfi Technologies until the correct paperwork is completed. If cross-border shipments are not labelled as per the instructions, the items may be held by customs and issued additional fees.

All returned items must be sent prepaid unless other specific arrangements have been made.

When the product or system is being shipped anywhere by courier or shipping company, it must be packaged in the original packaging it was received in. This measure greatly reduces the consequences of rough handling and subsequent shipping damage.

Eddyfi Technologies cannot be held responsible for damages due to improper packaging. Shipping damage may have significant impact on repair turnaround times.

Product/System Drawing Package Availability

Mechanical assembly and electrical wiring diagram drawing packages for your equipment are available in PDF format upon request. Printed copies may also be purchased from Eddyfi. Contact your local sales contact for more information.

Limited Warranty Policy

Refer the Eddyfi Technologies website for warranty terms for this product.

<https://www.eddyfi.com/en/salesterms>

Document: UMDT013103.docm	Revision: A20	Created by: KJB	Date: 16 Oct 2023	3070984-A22
Source Location: C:\ePDM\ISLEng\products\dt-versatrx100mkii\manuals\UMDT013103.docm				Page 50 of 50

The information in this document is accurate as of its publication. Actual products may differ from those presented herein.

© 2024 Eddyfi Canada, Inc. Ectane, and their associated logos are trademarks or registered trademarks of Eddyfi Canada, Inc. in the United States and/or other countries. Eddyfi Technologies reserves the right to change product offerings and specifications without notice. Eddyfi Technologies is a Previa Business Unit.

www.eddyfi.com

info@eddyfi.com



**Eddyfi
Technologies**
Beyond current