



**Technical  
Specifications**

# REMOTE-FIELD ARRAY PROBE

## High-resolution C-scans for carbon steel tubing

The Remote-Field Array (RFA) tube probe family brings high-resolution C-scan imaging to ferrous heat exchangers (HX) at conventional Remote-Field Testing (RFT) acquisition speeds. The technology is powered by a patent pending, low-frequency multiplexing protocol.

### HIGH-RESOLUTION C-SCAN IMAGE AT RFT SPEED

The RFA probe design combines a high-density array of coils with conventional bobbins featuring dual drivers. Powered by a patent pending low-frequency multiplexer, this solution enables the generation of high-resolution C-scan images, offering greater insight into the defect morphology and an overall improved assessment of the bundle. Designed with up to 30 coils, the probe family supports inspection of heat exchanger tube sizes ranging from 15.8mm to 31.75mm (0.625in to 1.25in).

### INCREASED COVERAGE

By design, conventional RFT probes offer a very limited performance near external features such as support plates and tubesheet. With RFA, the array of small sensors increases sensitivity, enabling detection of pits and small defects close to tubesheet and support plates. In general, RFA improves detection coverage, reducing blind zones surrounding external features by up to 75%, when compared to standard RFT inspections.

**Raising the standard with  
RFA for improved defect  
detection.**



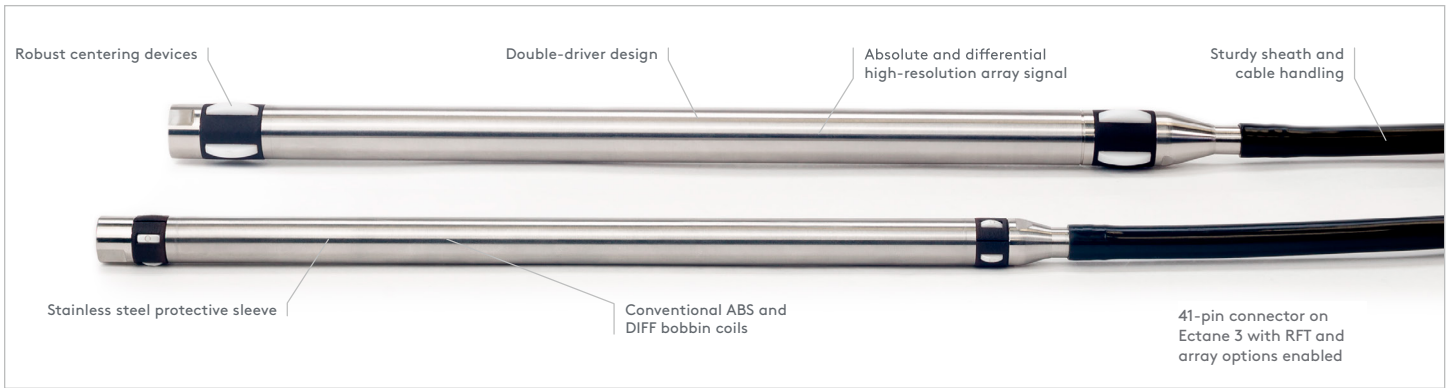

Figure 1: Annotated breakdown of the RFA probe.

## SAME RFT INSPECTION REQUIREMENTS, BETTER SIZING

RFA probes perform inspections at the equivalent speed of conventional RFT (typically around 300 mm/s or 12 in/s), and can be used with the same inspection preparation requirements for cleaning and fill factor. The conventional, absolute, and differential channels are simultaneously acquired and displayed.

The centering devices, engineered for carbon steel inspections and integrated with the probe design, lead to improved sizing capabilities on both the standard and array signals.

## FEATURES AND BENEFITS

- High-resolution C-scan imaging for greater insight on defect morphology, in addition to conventional strip charts and impedance plane displays
- Better detection of defects close to external features compared to conventional RFT
- Same pulling speed, cleaning, and fill factor requirements as conventional RFT
- Centering devices maintain constant liftoff in field conditions, leading to improved detection



Figure 2: Heat exchanger inspection with an RFA probe paired with the Ectane® 3.

## DATA ANALYSIS

- Magnifi software required: PRO, 5.1 and higher for acquisition and analysis
- ABS signal representation: Impedance or voltage plane
- Number of frequencies: 2
- Driver activation: independent
- Conventional and array (C-scan)

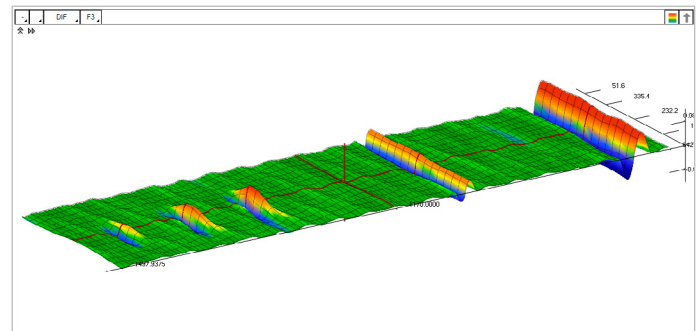

Figure 3: RFA data visualization

## PROBE DESIGN

- Recommended fill factor: 78% or more
- Diameters available: 15.8 to 35.75mm (6.2 to 140.7in) at 0.5mm (0.2in) increments
- Typical pulling speed: 300 mm/s or 12 in/s
- Frequency range: 50 – 2,000 Hz
- Number of drivers: 2
- Material: Ferrous (designed for carbon steel)
- Cable sheath: 9mm (0.375in) or 12.7mm (0.5in) strong, premium, non-kinking nylon
- Connector: 41-pin
- Protective sleeve: Stainless steel
- Centering devices: Ceramic feet with foam induced pressure
- Instrument model required: Ectane 3-E64RNM (I) or Ectane 3-E128RNM (I)

# NUMBER OF CHANNELS PER PROBE SIZE

| PROBE DIAMETER                  | BOBBIN | ARRAY |
|---------------------------------|--------|-------|
| 11 to 12mm (0.43 to 0.47in)     | 2      | 12    |
| 12.5 to 13.5mm (0.49 to 0.53in) | 2      | 14    |
| 14 to 15mm (0.55 to 0.59in)     | 2      | 16    |
| 15.5 to 16mm (0.61 to 0.63in)   | 2      | 18    |
| 16.5 to 17.5mm (0.65 to 0.69in) | 2      | 20    |
| 18 to 19mm (0.7 to 0.75in)      | 2      | 22    |
| 19.5 to 20mm (0.77 to 0.79in)   | 2      | 24    |
| 20.5 to 21.5mm (0.8 to 0.85in)  | 2      | 26    |
| 22 to 25mm (0.87 to 0.98in)     | 2      | 28    |

## PRBT-RFA-DDSA-XXXMF-N20

| TECHNOLOGY                  | MODEL | DIAMETER  | FREQUENCY             | POLY TYPE   | POLY LENGTH                                |
|-----------------------------|-------|---|-----------------------|---|--|
| RFA<br>(Remote-Field Array) | DDSA  | Specific to each model<br>3 digits including one decimal<br>Unit in mm<br>(e.g., 130 = 13.0 mm) | MF (Medium frequency) | N (Normal Nylon cable with<br>diameter based on probe OD) | 20: 20 m (65.6 ft.)<br>30: 30 m (98.4 ft.) |

# PROBE DIAMETERS

|         |       | TUBE WALL THICKNESS |       |       |       |       |       |       |       |       |       |       |       |       |       |       |     |
|---------|-------|---------------------|-------|-------|-------|-------|-------|-------|-------|-------|-------|-------|-------|-------|-------|-------|-----|
| BWG     |       | 4                   | 5     | 6     | 7     | 8     | 9     | 10    | 11    | 12    | 13    | 14    | 15    | 16    | 17    | 18    |     |
| mm      |       | 6,05                | 5,59  | 5,16  | 4,57  | 4,19  | 3,76  | 3,4   | 3,05  | 2,77  | 2,41  | 2,11  | 1,83  | 1,65  | 1,47  | 1,24  |     |
| in      |       | 0,238               | 0,220 | 0,206 | 0,180 | 0,165 | 0,148 | 0,135 | 0,120 | 0,109 | 0,095 | 0,083 | 0,072 | 0,065 | 0,058 | 0,049 |     |
| TUBE OD | 15.87 | 0.625               | -     | -     | -     | -     | -     | -     | -     | -     | 100   | 105   | 110   | 110   | 115   | 120   |     |
|         | 19.05 | 0.750               | -     | -     | -     | -     | -     | 110   | 115   | 120   | 125   | 130   | 135   | 140   | 140   | 145   |     |
|         | 22.22 | 0.875               | -     | -     | -     | 115   | 120   | 130   | 135   | 140   | 145   | 155   | 160   | 165   | 170   | 175   |     |
|         | 25.40 | 1.000               | 115   | 125   | 135   | 145   | 150   | 160   | 165   | 170   | 175   | 180   | 185   | 190   | 195   | 200   | 200 |
|         | 31.75 | 1.250               | 175   | 180   | 190   | 200   | 205   | 215   | 220   | 225   | 230   | -     | -     | -     | -     | -     |     |

The information in this document is accurate as of its publication. Actual products may differ from those presented herein. © 2024 Eddyfi Canada, Inc. Eddyfi Technologies, Deffi, I-Flex, Magnifi, Shark, TECA, and their associated logos are trademarks or registered trademarks of Eddyfi Canada, Inc. in the United States and/or other countries. Eddyfi Technologies reserves the right to change product offerings and specifications without notice. Eddyfi Technologies is a Previa Business Unit.

