

Getting Started with U41



© Eddyfi NDT, Inc.

3425 Pierre-Ardouin Québec (QC)
G1P 0B3 CANADA

Eddyfi NDT, Inc. ACFM, Amigo, Sensu, TSC, and their associated logos are trademarks or registered trademarks of Technical Software Consultants Ltd. (wholly owned subsidiary of Eddyfi NDT, Inc.) in the United Kingdom and/or other countries. Eddyfi Technologies reserves the right to change product offerings and specifications without notice.

2019-10-11

Contents

General Precautions and Conventions

General Precautions vi

Safety Precautions vi

Conventions vii

Typographical vii

Marking and Symbols vii

Safety Indications in This Document viii

Acronyms viii

EMC Directive Compliance viii

FCC Compliance (USA) viii

ICES Compliance (Canada) viii

AS/NZS Compliance (Australia/New Zealand) ix

CE Compliance (EU) ix

Maritime Environment Compliance ix

Calibration and Warranty Seals ix

Limited Warranty x

Copyrights x

System Overview

Introducing the U41 System 2

What is in the Box 2

Optional Accessories 2

System Hardware Setup 3

Overview 3

Setup for Diver 4

Setup for ROV 5

Configuring the communications 8

Alternative LAN topologies 8

U41 subsea bottle network settings 9

Topside Unit network settings 10

Testing network settings 10

Operation with ROV 11

U41 subsea bottle to Topside Unit protocols 11

Topside Unit configuration 11

U41 subsea bottle configuration 12

The Subsea Bottle

Introduction to Subsea Bottle 16

Specifications 17

General specifications for Model D, DA and R 17

Connectors 18

Umbilical 18

Pinout 18

| | |
|---|-----------|
| Probes | 19 |
| Probe connection | 19 |
| Maintenance of the subsea bottle | 19 |
| Connectors | 19 |
| Instrument and Cables | 19 |
| The Topside Unit | |
| Introduction to the topside unit | 22 |
| Safety Trip device | 23 |
| Extension cord | 23 |
| Specifications | 23 |
| General specifications | 23 |
| Environmental specifications | 23 |
| Connectors | 24 |
| Umbilical | 24 |
| Maintenance of the topside unit | 27 |
| Cleaning instructions | 27 |
| Assist3 Software | |
| Introduction to Assist3 software | 29 |
| Backstage | 29 |
| General | 30 |
| Job Details | 30 |
| Select Probe | 32 |
| File Transfer | 33 |
| Start/Resume | 33 |
| Documentation | 34 |
| Preferences | 34 |
| System | 34 |
| Frontstage | 37 |
| Layout | 37 |
| Pinning side and bottom tabs | 38 |
| Information bar and warnings | 39 |
| Home ribbon | 40 |
| Scanning ribbon | 41 |
| Configuring Markers | 42 |
| Origin Dialogue Box | 43 |
| Replay Ribbon | 44 |
| Size | 45 |
| Defect List Box | 46 |
| Adding a Region | 47 |
| Regions List Box | 47 |
| Creating an Automated Report | 48 |
| Layout ribbon | 49 |

| | |
|--|-----------|
| Manipulating C-scan Appearance | 52 |
| Keyboard shortcut keys | 52 |
| Updating and upgrading the software | 54 |
| Method | 54 |
| Troubleshooting | |
| Safety device trips | 58 |

Figures

| | |
|---|----|
| Figure 1-1 System hardware connections | 3 |
| Figure 1-2 Diver setup | 4 |
| Figure 1-3 ROV setup | 5 |
| Figure 1-4 ROV setup - power and communication taken from ROV | 5 |
| Figure 1-5 ROV Connections | 6 |
| Figure 1-6 LAN topologies | 8 |
| Figure 1-7 Software - Subsea bottle configuration | 9 |
| Figure 1-8 Software - Subsea bottle Ethernet configuration | 9 |
| Figure 1-9 Software - Subsea bottle IP mode configuration | 9 |
| Figure 1-10 Software - Topside unit configuration | 10 |
| Figure 1-11 Software - Topside unit configuration | 10 |
| Figure 1-12 Software - Topside IP mode configuration | 10 |
| Figure 1-13 Software - Test network settings | 11 |
| Figure 1-14 Operation with ROV - Topside configuration | 11 |
| Figure 1-15 Operation with ROV - Topside configuration | 12 |
| Figure 1-16 Operation with ROV - Topside configuration | 12 |
| Figure 1-17 Operation with ROV - Subsea bottle configuration | 12 |
| Figure 1-18 Operation with ROV - Subsea bottle configuration | 13 |
| Figure 1-19 Operation with ROV - Subsea bottle configuration | 13 |
| Figure 1-20 Operation with ROV - Subsea bottle configuration | 14 |
| Figure 1-21 Operation with ROV - Subsea bottle configuration | 14 |
| Figure 2-1 U41 bottle - side view | 17 |
| Figure 2-2 U41 bottle - top view | 17 |
| Figure 2-3 Umbilical connector | 19 |
| Figure 3-1 Topside unit | 23 |
| Figure 3-2 Topside unit - umbilical connector | 25 |
| Figure 3-3 Power in connector | 26 |
| Figure 3-4 Power out connector | 26 |
| Figure 3-5 Ethernet connector | 27 |
| Figure 4-1 Backstage view: General | 31 |
| Figure 4-2 Connect/disconnect | 32 |
| Figure 4-3 Select probe | 33 |
| Figure 4-4 View imported probes | 33 |

| | |
|--|----|
| Figure 4-5 Backstage view: Documentation | 35 |
| Figure 4-6 Backstage view: Preferences/System | 35 |
| Figure 4-7 Company logo | 36 |
| Figure 4-8 Backstage view: Preferences/Display | 37 |
| Figure 4-9 Backstage view: Help | 37 |
| Figure 4-10 Frontstage layout | 38 |
| Figure 4-11 Frontstage screen | 38 |
| Figure 4-12 Pin tabs | 39 |
| Figure 4-13 Information bar and warnings | 40 |
| Figure 4-14 Home Ribbon | 41 |
| Figure 4-15 Coating thickness dialogue box | 41 |
| Figure 4-16 Scanning ribbon | 42 |
| Figure 4-17 Marker setup dialogue box | 43 |
| Figure 4-18 Origin dialogue box | 44 |
| Figure 4-19 Row Visibility Tab | 44 |
| Figure 4-20 Analysis ribbon | 45 |
| Figure 4-21 Replay Ribbon | 45 |
| Figure 4-22 Sizing | 46 |
| Figure 4-23 Defects list box | 47 |
| Figure 4-24 Adding a region | 48 |
| Figure 4-25 Regions list box | 48 |
| Figure 4-26 ACFM Page Report | 49 |
| Figure 4-27 Layout ribbon | 50 |
| Figure 4-28 Standard view | 50 |
| Figure 4-29 Layout 2 | 51 |
| Figure 4-30 Layout 3 | 51 |
| Figure 4-31 Layout 4 | 52 |
| Figure 4-32 Layout 5 | 52 |
| Figure 4-33 Keyboard Shortcuts | 54 |
| Figure 4-34 Launching the Setup wizard | 55 |
| Figure 4-35 Accepting the license agreement | 55 |
| Figure 4-36 Installing the software | 55 |
| Figure 4-37 Finishing the installation | 56 |
| Figure 4-38 Finish the installation | 57 |

General Precautions and Conventions

General Precautions

The following safety precautions are to be observed at all times when using U41®. Make sure that you review them **before** turning on the system.

- Keep this document in a safe place for future reference.
- Carefully follow the installation and operation procedures detailed herein.
- Respect the safety warnings on the instrument and in this document.
- U41 should only be used by certified personnel.
- When transporting U41, it is your responsibility to make sure that you apply the safety precautions dictated by the relevant local governing bodies.
- Always connect the power supply to a properly grounded receptacle, extension cord, or power bar. Grounding a single conductor of a two-conductor outlet is not sufficient protection for U41.
- Only connect the system to a power source corresponding to the type indicated on the rating plate.
- If you use the system in a manner that deviates from the one specified by Eddyfi, the protection provided on the equipment may be rendered null and void.
- Do not use substitute parts or perform unauthorized modifications to the system.
- Service instructions, when applicable, are intended for trained service personnel only.
- Always make sure that the system is unplugged from any power supply before servicing.
- To avoid a dangerous electric shock, do not perform any service on the system unless trained to do so. If you encounter any problems or have questions regarding this system, contact Eddyfi Tech-nologies or an authorized Eddyfi Technologies representative.
-

Safety Precautions

Observe the following safety precautions scrupulously when using U41.

The safety of operators and divers was paramount in the design and implementation of the U41 system. Beyond the passive design features which provide industry standard levels of electrical safety, additional AC and DC safety trip devices have been included to further protect operators and divers from potential failures and damage to the electrical system.

The system should never be used if the devices are missing, have been disabled or repeatedly trip.

These devices should be tested every time that the system is first powered on.

Read section Safety Trip device for more information on the integrated safety device.

Conventions

Typographical

The following typographical conventions are used throughout this document:

Italic

Used for file names and paths.

Bold

Used to indicate menu items, named user interfaces, and place emphasis on specific words or phrases. Items in bold type are capitalized to reflect the actual interface.

SMALL CAPITALS

Used to indicate instrument interface indications.

Marking and Symbols

The following symbols appear on the instrument and pertain to safety regulations that should be carefully observed:



This label is used as a general warning sign. It indicates that you should refer to this user's guide to obtain the necessary information for proper protection of the instrument and its users.



This label is used to indicate high voltage. It draws your attention to the presence of hazardous voltages (within the product enclosure or accessible externally) that may constitute a risk of electric shock to persons. Always refer to the user's guide to ensure proper protection and safety.



The RoHS compliance logo signifies that this product complies with the Restriction of Hazardous Substances directive 2002/95/EC. This directive restricts the use of lead, mercury, cadmium, hexavalent chromium, polybrominated biphenyl, and polybrominated diphenyl ether in certain classes of electrical and electronic units as of July 1, 2006.



This label acts as a reminder that you should dispose of this system in accordance with your local Waste Electrical and Electronic Equipment (WEEE) regulations. This system was manufactured to the high-quality standards of Eddyfi to ensure safe and reliable operation when it is used as stated in this document. Due to its nature, this instrument may contain small quantities of substances known to be hazardous to the environment and to human health if released in the environment. As such, systems falling under WEEE regulations should not be disposed of in the public waste stream.

Safety Indications in This Document

The safety indications in this document are intended to ensure your safety and the integrity of the system.

WARNING!



Warning

The warning indication calls your attention to a procedure or a practice (or the like) that, if performed incorrectly, can result in injury. Do not ignore warning indications make sure that you understand the condition before proceeding.

CAUTION



Caution

The caution indication calls your attention to a procedure or practice (or the like) that, if performed incorrectly, can result in material damage, loss of data, or both. Do not ignore caution indications make sure that you understand the condition before proceeding.

Important

Calls attention to important information in order to complete the tasks.

Note

Calls attention to an operating procedure, a practice, or the like that requires special attention. Notes also indicate useful related information, but the parenthetical information is not mandatory.

Acronyms

| | |
|-------|---------------------------------------|
| ACFM: | Alternating current field measurement |
| HAZ: | Heat affected zone |
| UI: | User interface |
| A/C: | Anticlockwise/Clockwise |
| T: | Transverse |
| Fe: | Ferrous |

EMC Directive Compliance

FCC Compliance (USA)

This equipment was tested and found to comply with the limits for a Class A digital device, pursuant Part 15 of the FCC Rules. These limits are designed to provide reasonable protection against harmful interference when the equipment is operated in a commercial environment. This equipment generates, uses, and can radiate radio frequency energy and, if not installed and used in accordance with the user's guide, may cause harmful interference to radio communications. Operation of this equipment in a residential area is likely to cause harmful interference in which case you will be required to correct the interference at your own expense.

ICES Compliance (Canada)

This ISM device complies with Canadian ICES-001.

Cet appareil ISM est conforme à la norme NMB-001 du Canada.

AS/NZS Compliance (Australia/New Zealand)

This device complies with Australia and New Zealand AS/NZS 4252.2 (IEC 61000-6-4) and AS/NZS 61000-6-2 (IEC 61000-6-2).

CE Compliance (EU)

This device complies with the Electromagnetic Compatibility Directive 2014/30/UE.

Maritime Environment Compliance

This device complies with the IEC 60945 and IEC 60533.

Calibration and Warranty Seals

The calibration seal is at the back of the instrument. U41 is also equipped with a warranty seal.

Important

Broken seals void the calibration certification and product warranty.

Limited Warranty

Eddyfi NDT, Inc. warrants the hardware to be free of any defects in materials or workmanship for a period of twelve (12) months from the date of delivery, under normal use and service. These warranties are limited to the original purchase of the product and are not transferable.

Eddyfi NDT, Inc. will repair or replace any product component or documentation, at its option and at no additional charge if found defective within the warranty period. The purchaser is responsible for returning the product to Eddyfi NDT, Inc.

Eddyfi NDT, Inc., will not be held responsible in any way whatsoever for damage resulting from improper installation, accident, misuse, or from service or modification of the product by anyone other than Eddyfi NDT, Inc., or an authorized Eddyfi NDT, Inc. service center.

Eddyfi NDT, Inc. will not be held responsible in any way whatsoever for direct, indirect, special, incidental, or consequential damages resulting from possession, use, improper installation, accident, service, modification, or malfunction of the product (including, without limitation, damages for loss of business profits, business interruption, loss of business information, or other pecuniary loss). Eddyfi's total shall in no event exceed the purchase price of the applicable item(s).

This warranty is in lieu of all other warranties, whether oral, written, expressed, or implied, including any warranty of merchantability or fitness for a particular purpose, and no other representation or claims of any nature shall be binding on or obligate Eddyfi NDT, Inc.

This agreement is governed by the laws of the province of Québec, Canada. Each of the parties hereto irrevocably attorns to the jurisdiction of the courts of the province of Québec and further agrees to commence any litigation which may arise hereunder in the courts located in the judicial district of Québec.

Copyrights

This document and the product and programs it describes are protected by the Copyright Act of Canada, by laws of other countries, and by international treaties, and therefore may not be reproduced, in whole or in part, whether for sale or not, without prior written consent from Eddyfi NDT, Inc. Under copyright law, copying includes translation in other languages and formats.

© Eddyfi NDT Inc., 2019

This document was prepared with particular attention to usage to ensure the accuracy of the information it contains. It corresponds to the version of the product manufactured prior to the date appearing on the back cover. There may, however, be some differences between this document and the product if the product was modified after publication.

The information contained in this document is subject to change without notice.

Chapter 1

System Overview

Introducing the U41 System

Thank you for purchasing the Eddyfi® TSC U41 system, the most advanced ever system for inspecting subsea structures using the Alternating Current Field Measurement (ACFM®) technique

The U41 is the successor to the previous generation U31 instrument and contains the following class leading features:

- 3 probe connectors, to reduce time spent changing out probes,
- Vastly improved electronics delivering increased speed and data resolution
- Removable handle to facilitate easy probe connector access
- Impact bumpers
- Ability to use up to 3 umbilicals joined together (450m (1476ft) total).
- The U41 is available in 4 models: 2 are for use with divers and 2 are for use with ROVs.
- U41D™ - basic model for divers which uses simple twin sensor probes
- U41DA™ - standard model for divers which also supports a mini-array probe for increased productivity
- U41R™ - can be integrated for use with ROVs and supports a range of array probes designed for remote deployment
- U41RDW™ - the same functionality as the U41R but in a larger pressure bottle for operation at water depths up to 2000m

We will cover what's in the box then take an overview of the instrument and its main functions and application capabilities.

What is in the Box

The U41 comes with the following system components and accessories:

- U41 Subsea Bottle with removable handle
- Blanking plugs (2) (for unused probe connectors)
- Topside Unit (different models for D or R versions)
- Topside Unit power cable with RCD
- Ethernet cable
- 230Vac to 110Vac transformer
- Test & integration deck cable (20m (65 feet))
- Function check plate

Optional Accessories

Here is a list of the optional accessories that could be included depending of the option selected.

- Rugged laptop running ASSIST3. Note you may use your own laptop with the system but you will need to download, install and license the ASSIST3 software before use.
- 150m Subsea umbilical cable on drum. This is used for all diver operations and for ROV operations where the U41 subsea bottle does not have a power and communications connection through the ROV umbilical. Note that up to three 150m umbilicals may be joined together if required.
- Topside integration whip. For ROV operations this connects the topside communications connector to the ROV interface electronics.
- Subsea integration whip. For ROV operations, this connects the subsea bottle to the ROV for power and communications.
- All these accessories are available directly from Eddyfi Technologies. Contact your local sales representative or office for more information.

System Hardware Setup

Overview

The functional connections required for both diver and ROV operations are similar with the main difference being the umbilical used between the topside unit and subsea bottle: the diver unit always uses the Eddyfi supplied 150m subsea umbilical whereas the ROV system may use either the Eddyfi umbilical or use the ROV umbilical, as required. The connections are shown in block diagram form below:

Figure 1-1 System hardware connections

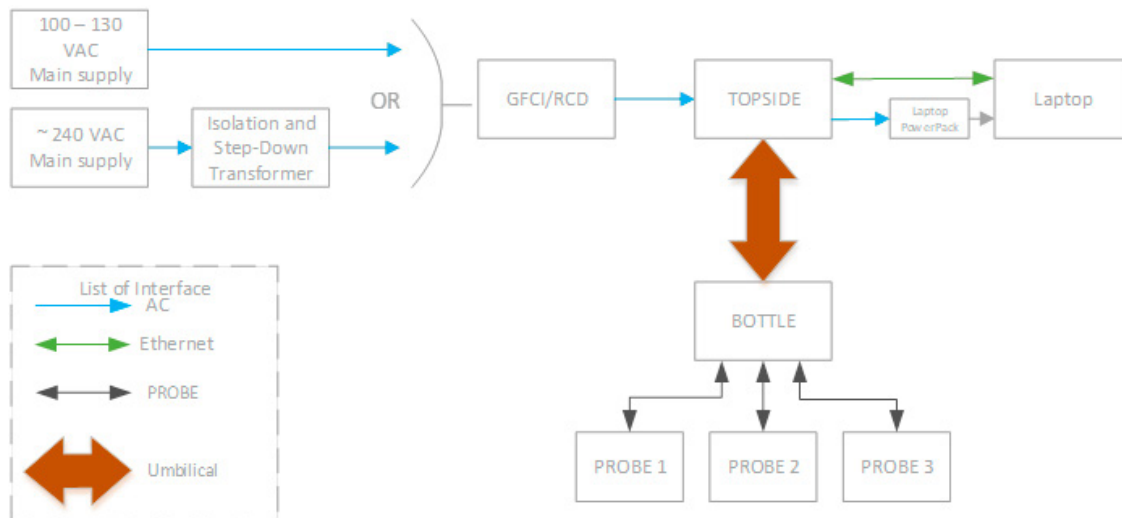

Setup for Diver

The basic connections and setup procedure to configure the system for diver deployment is shown below:

Figure 1-2 Diver setup

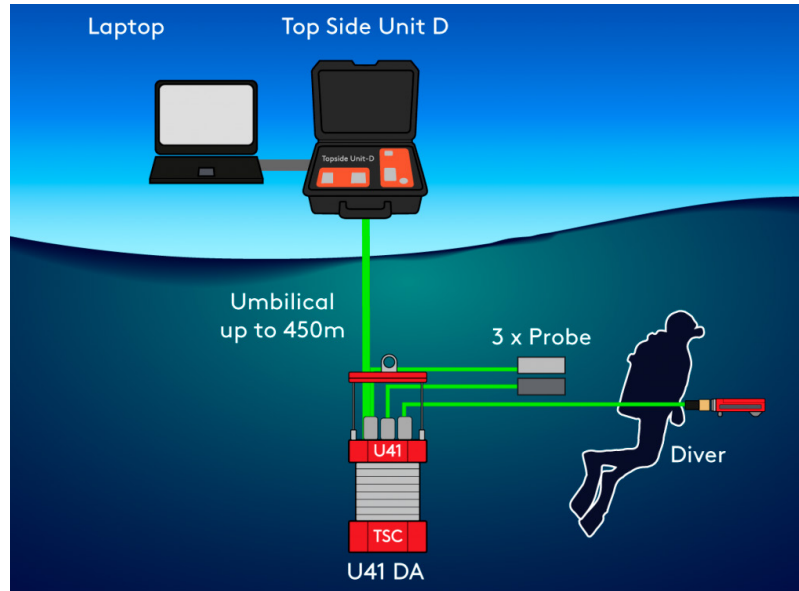

1. Ensure all mains switches are OFF.
2. Connect the topside unit to the mains supply using the RCD protected lead. If the local supply is 230Vac then the included transformer will be required.
3. Connect the computer to the U41D topside unit, using the Ethernet cable. If the computer needs to be powered from the mains supply, instead of running from the internal battery, connect the mains lead to the 110V output connector on the topside unit. For more advanced connection options, see Configuring the communications on page 8.
4. Connect the test and integration deck cable to the topside unit and connect the main umbilical(s) to the other end of the test umbilical. Note that up to 3 main umbilicals may be connected in series depending on requirements.
5. Connect the main umbilical(s) to the subsea unit.
6. Connect the probe(s) to be used to the U41 subsea unit. Ensure that any probe connector which doesn't have a probe connected to it is fitted with a blanking plug. Deploying the bottle subsea with an exposed connector will cause severe damage to the unit.
7. Test the main cable RCD by turning ON the mains supply to the lead (with the topside unit still switched OFF). Press the Reset button and verify that the red indicator is showing. Press the Test button and confirm that the red indicator is removed. Press the Reset button again and check that the red indicator reappears and remains. If this does not function, or if during operation the RCD trips repeatedly, suspend all operations, turn off mains supply and seek specialist advice.
8. Check to insure the 110v indicator panel is illuminated.
9. Turn on the power to the U41 system by pressing the power switch on the topside unit panel.
10. Test the safety trip on the topside unit. Press the Reset button and verify that the blue indicator on the power switch is showing. Press the Test button and confirm that the blue indicator is removed and the red fault light is displayed. Press the Reset button again and check that the red fault light is extinguished and the blue power button light reappears and remains. If this does not function, or if during operation the safety trip trips repeatedly, suspend all operations, turn off mains supply and seek specialist advice.
11. The subsea bottle will take approximately 20 seconds to initialise following the safety trip tests. Switch on the computer and start the ASSIST™ software.

12. From the Backstage screen, press the Connect button. Select the instrument from the available list and press the Connect button on this panel. For more advanced connection options, see Configuring the communications on page 8
13. Test the correct functioning of the system by performing function checks on all probes connected to the bottle.

Setup for ROV

There are two main setups for deploying U41R by ROV. The first uses the Eddyfi umbilical and the subsea bottle is electrically separate from the ROV for its power and communications. An example of this deployment is shown below:

Figure 1-3 ROV setup

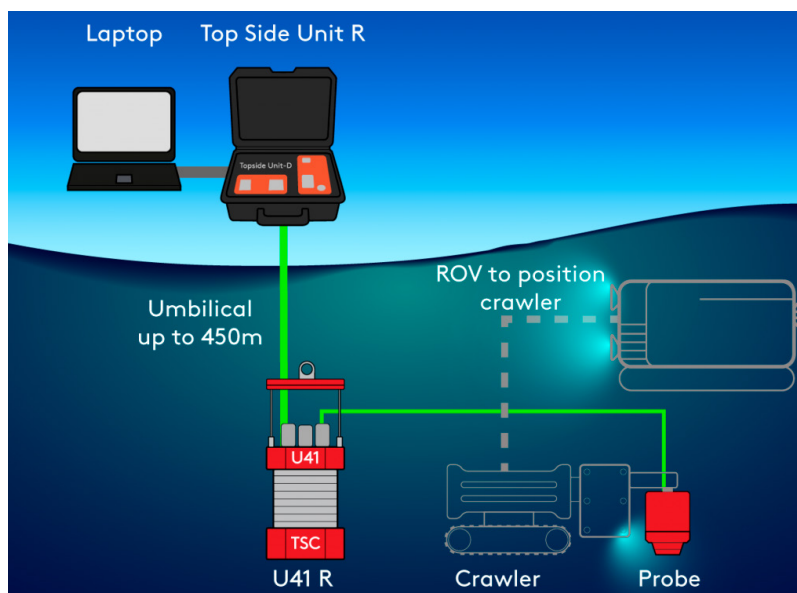

In this example the same general setup as used for the diver unit is used, see Setup for Diver on page 4

The second main method is where the subsea bottle takes its power and communications from the ROV itself.

Figure 1-4 ROV setup - power and communication taken from ROV

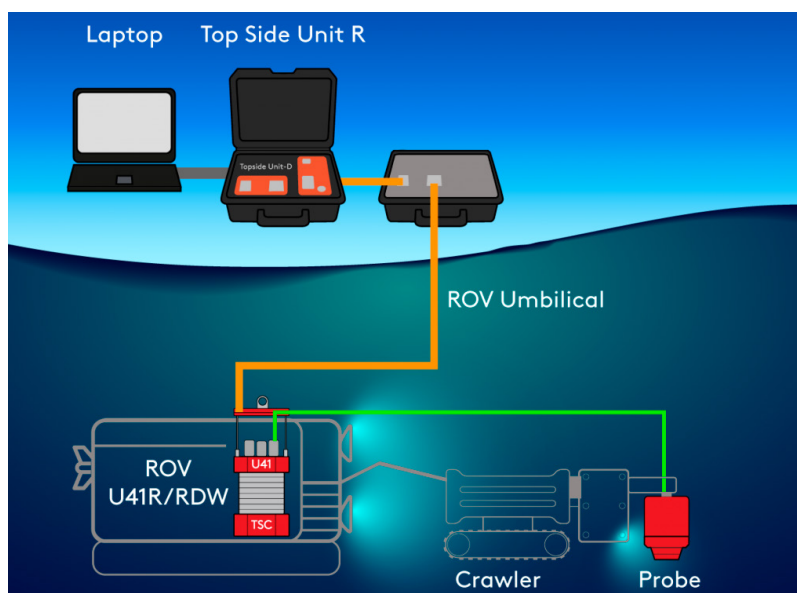
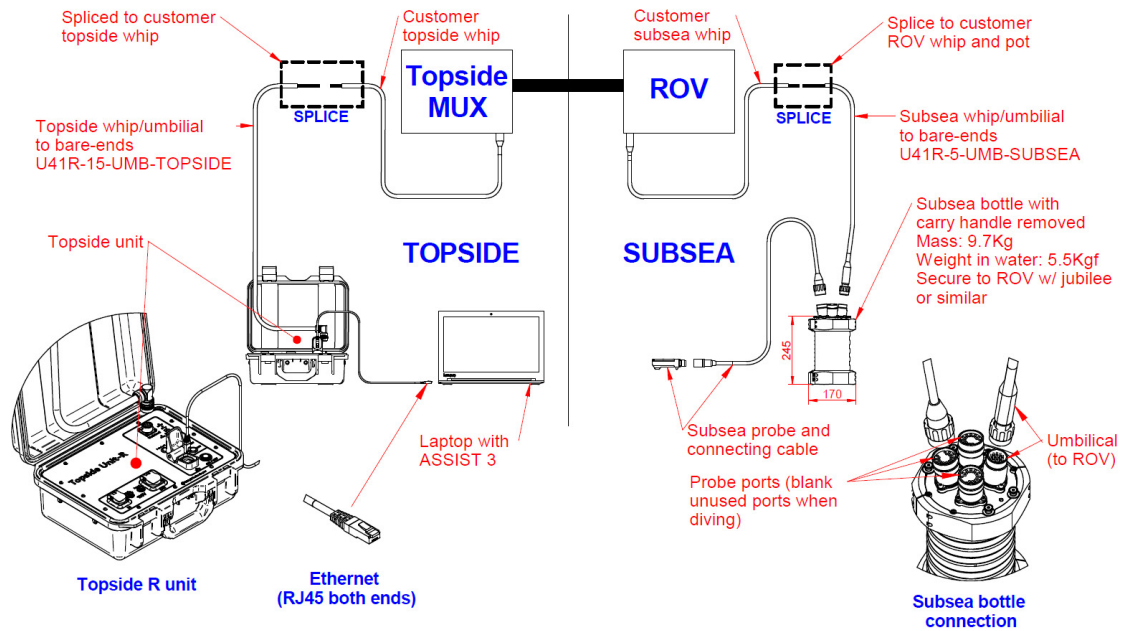

Figure 1-5 ROV Connections



1. Decide on the communications protocol to be used through the ROV system.
2. Ensure all mains switches are OFF.
3. Connect the topside unit to the mains supply using the RCD protected lead. If the local supply is 230Vac then the included transformer will be required.
4. Connect the computer to the U41D topside unit, using the Ethernet cable. If the computer needs to be powered from the mains supply, instead of running from the internal battery, connect the mains lead to the 110-120Vac output connector on the topside unit. For more advanced connection options, see Configuring the communications on page 8.
5. Connect the test and integration deck cable to the topside unit and subsea bottle.
6. Test the main cable RCD by turning ON the mains supply to the lead (with the topside unit still switched OFF). Press the Reset button and verify that the red indicator is showing. Press the Test button and confirm that the red indicator is removed. Press the Reset button again and check that the red indicator reappears and remains. If this does not function, or if during operation the RCD trips repeatedly, suspend all operations, turn off mains supply and seek specialist advice. Note that in this configuration, the topside unit does not provide DC power to the instrument via the umbilical, this instead comes from the ROV supply.
7. Check to insure the 110v indicator panel is illuminated.
8. Turn on the power to the U41 system by pressing the power switch on the topside unit panel. If the blue indicator light in the switch does not light, press the reset button in the Safety Trip area.
9. The subsea bottle will take approximately 20 seconds to initialise. Switch on the computer and start the ASSIST™ software.
10. Configure the communications between topside unit and subsea bottle to match the protocol decided in step 1. See Operation with ROV on page 11. Check that the subsea bottle can be connected to using the new protocol.
11. Power down the topside unit, remove the deck cable and secure the subsea bottle to the ROV.
12. Temporarily connect the free end of the Eddyfi supplied subsea communications whip to the ROV subsea cable, supplied by the ROV team. The power wires and the communication protocol wires, decided in step 1, must be connected.
13. Power up the ROV port and test that the correct power voltages are present on the bottle end of the Eddyfi supplied subsea whip, see Umbilical on page 18 Power down the port.

- 14.** Connect the Eddyfi supplied subsea whip to the subsea bottle umbilical connector
- 15.** Connect the Eddyfi supplied topside whip free end relevant communication wires to the ROV topside integration port. See Connectors on page 24. Connect the other end to the topside unit umbilical connector.
- 16.** Connect the probe(s) to be used to the U41 subsea unit. Ensure that any probe connector which doesn't have a probe connected to it is fitted with a blanking plug. Deploying the bottle subsea with an exposed connector will cause severe damage to the unit.
- 17.** Power up the topside unit and ROV port. Using ASSIST, attempt to connect to the subsea bottle. If there is no connection, re-check the physical connections and, if using serial protocols, try swapping Rx and Tx at one end of the ROV interface.
- 18.** Once communications are established, function check the probe on the test plate to ensure that data is passing reliably through the system.

Configuring the communications

Alternative LAN topologies

Connection of PC or laptop to U41 systems is usually via a standard RJ45 CAT5 style LAN cable directly from the computer to the instrumentation. This is the default setup and configuration is not normally required. However, if LAN configuration changes have been made since the system was received, these may need to be undone for the original operation to function again.

Alternative configurations are available, providing benefits such as using existing premises LAN and enabling use of a single PC LAN port. The most common scenarios are shown below.

Figure 1-6 LAN topologies

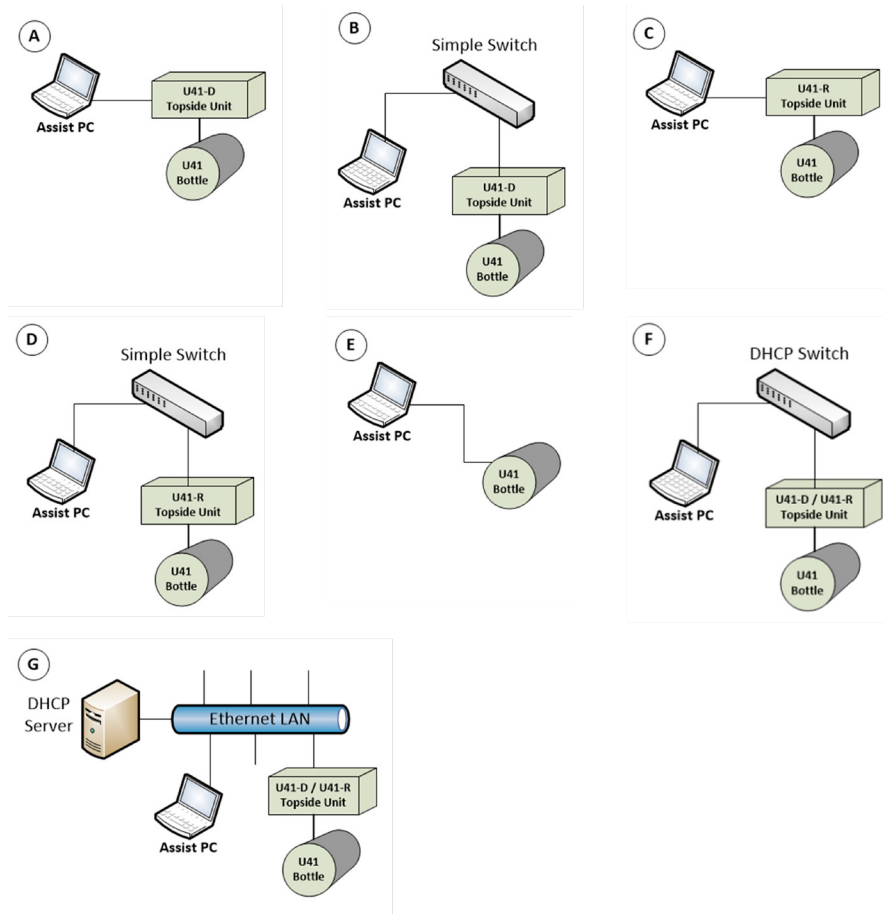

Configuring these alternative networking scenarios differs between U41-D and U41-R systems. The table below outlines the recommended settings.

| Scenario | System | Topside Unit | U41 Bottle |
|----------|----------------|--------------|-------------|
| A | U41-D | --- | DHCP Server |
| B | U41-D | --- | DHCP Server |
| C | U41-R | DHCP Server | DHCP Client |
| D | U41-R | DHCP Server | DHCP Client |
| E | U41-D or U41-R | --- | DHCP Server |
| F | U41-D | --- | DHCP Client |
| F | U41-R | DHCP Client | DHCP Client |
| G | U41-D | --- | DHCP Client |
| G | U41-D | DHCP Client | DHCP Client |

Using the table above, follow the instructions below to configure the U41 subsea bottle and Topside Unit network settings appropriately.

U41 subsea bottle network settings

From the Backstage/General tab, configure the U41 bottle by pressing the Connect button.

Figure 1-7 Software - Subsea bottle configuration

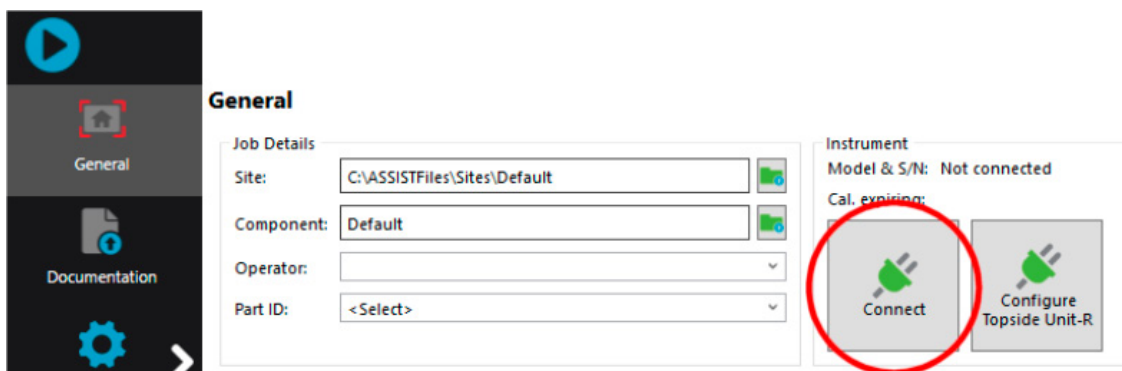

Then from the dialogue like the one shown below, select the 'U41 - Ethernet' instrument and click the Config Cog.

Figure 1-8 Software - Subsea bottle Ethernet configuration

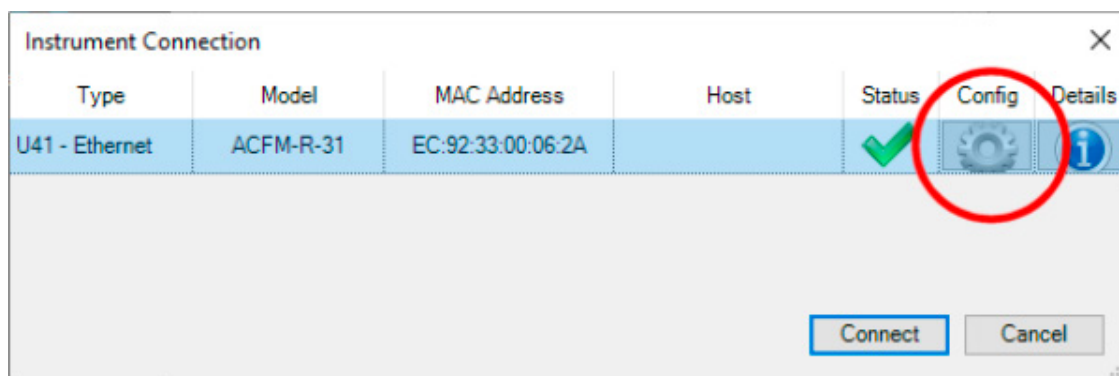

A dialogue similar to the one shown below should appear.

Figure 1-9 Software - Subsea bottle IP mode configuration

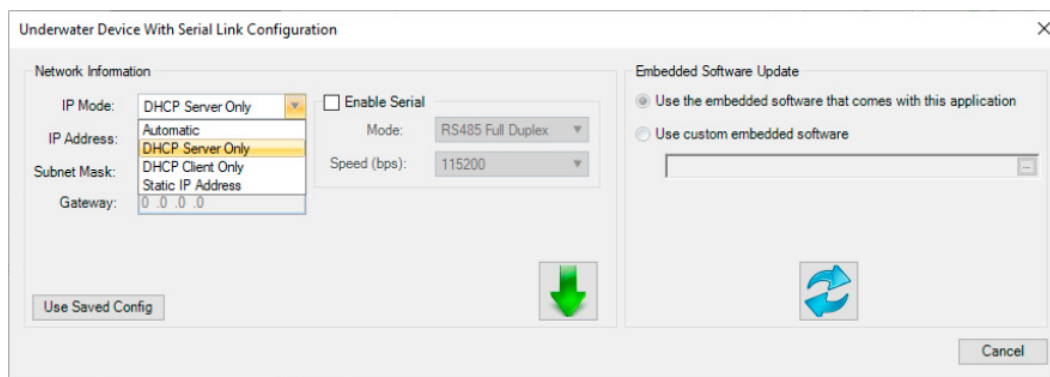

Select the required IP Mode from the list according to the scenario and table above.

Topside Unit network settings

From the Backstage/General tab, configure the Topside Unit by pressing the Configure Topside Unit R button.

Figure 1-10 Software - Topside unit configuration



Then from the dialogue like the one shown below, select the 'Topside Unit' instrument and click the Config Cog.

Figure 1-11 Software - Topside unit configuration

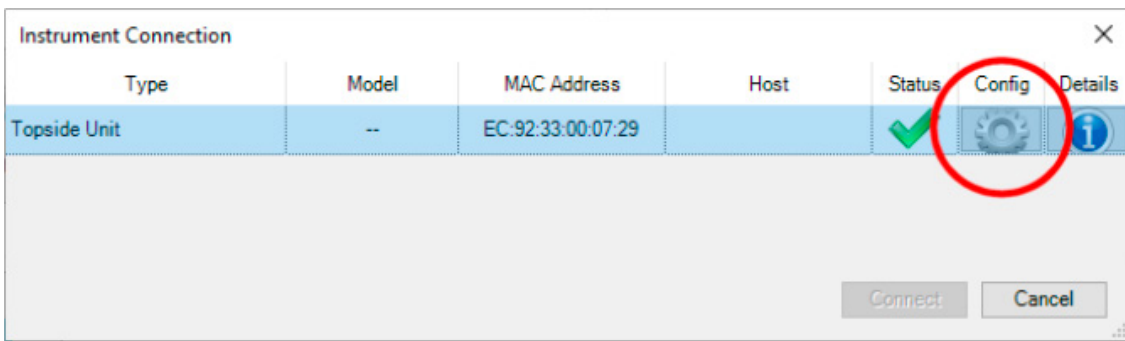

A dialogue similar to the one shown below should appear.

Figure 1-12 Software - Topside IP mode configuration

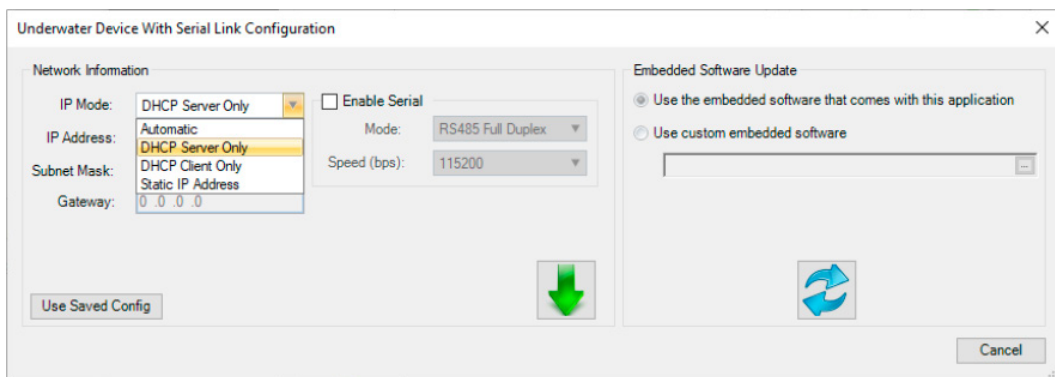

Select the required IP Mode from the list according to the scenario and table above.

Testing network settings

From the Backstage/General tab, press the Connect button. A dialogue similar to the one shown below should appear.

Figure 1-13 Software - Test network settings

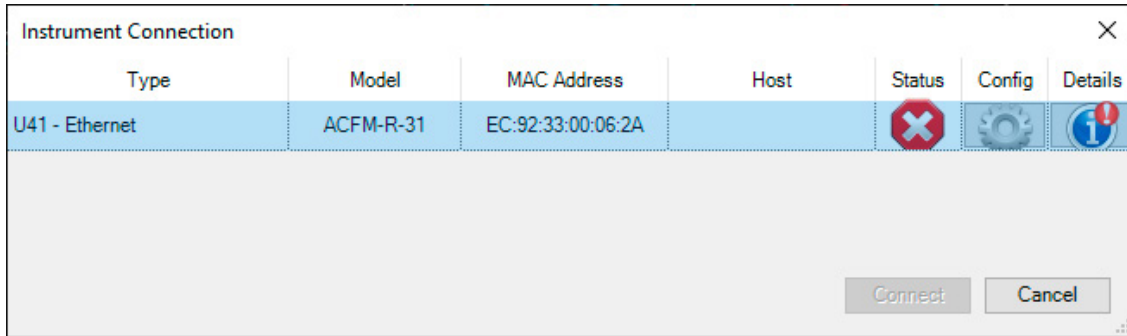

For the 'U41 - Ethernet' instrument Type line, check for the following.

- The Status column is not a green tick
- The Details column contains an alert icon
- There is no 'U41 -Ethernet' instrument Type present

If any of these conditions are found, there could be a problem with the LAN configuration. First wait for at least one minute for the system to auto-adjust to any LAN environment changes.

If the problem continues, some adjustment to cabling or network settings of the U41 system or laptop may be necessary. Information about the type of problem may be found by holding the mouse over the Status, Config or Details icons or by clicking on the Details icon.

For guidance on how to configure the U41 system network settings, see Alternative LAN Topologies on page 8

Operation with ROV

U41 subsea bottle to Topside Unit protocols

[Important: The integration cable should be connected while performing these changes to ensure communication to the subsea bottle is not lost.]

To establish successful communication requires setting matching configurations in both the Topside Unit and U41 subsea bottle.

Topside Unit configuration

From the Backstage/General tab, configure the Topside Unit by pressing the Configure Topside Unit R button.

Figure 1-14 Operation with ROV - Topside configuration

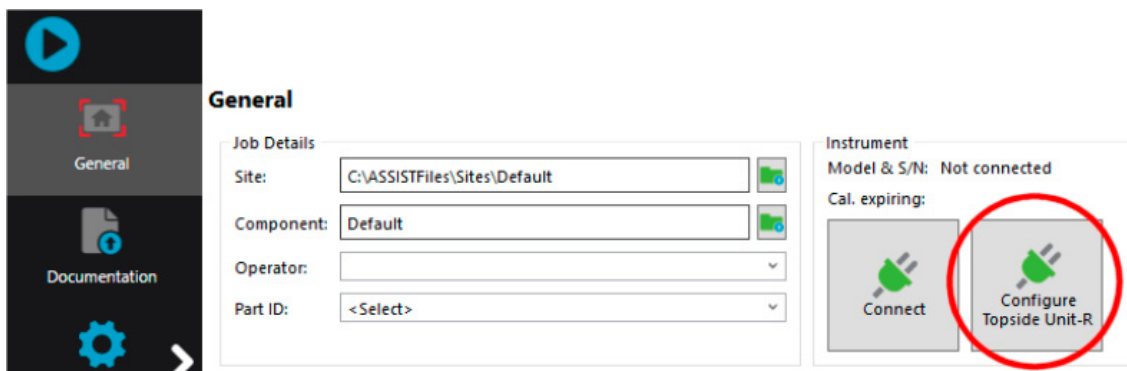

Then from the dialogue like the one shown below, select the 'Topside Unit' instrument and click

the Config Cog.

Figure 1-15 Operation with ROV - Topside configuration

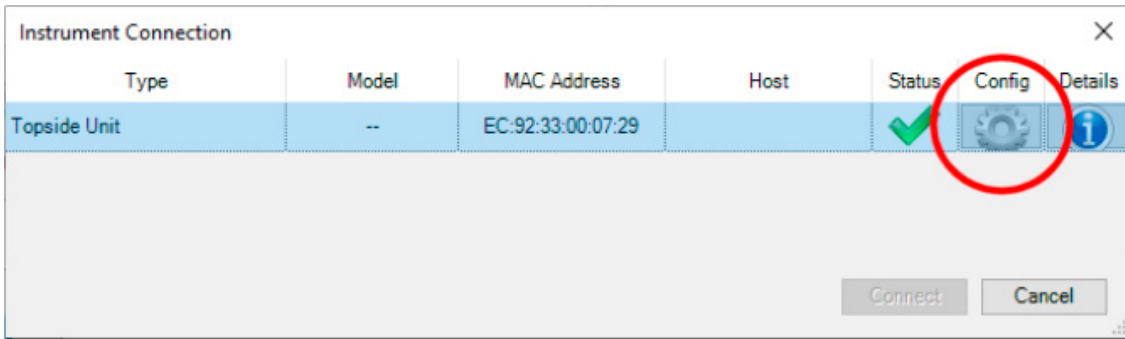

A dialogue similar to the one shown below should appear.

Figure 1-16 Operation with ROV - Topside configuration

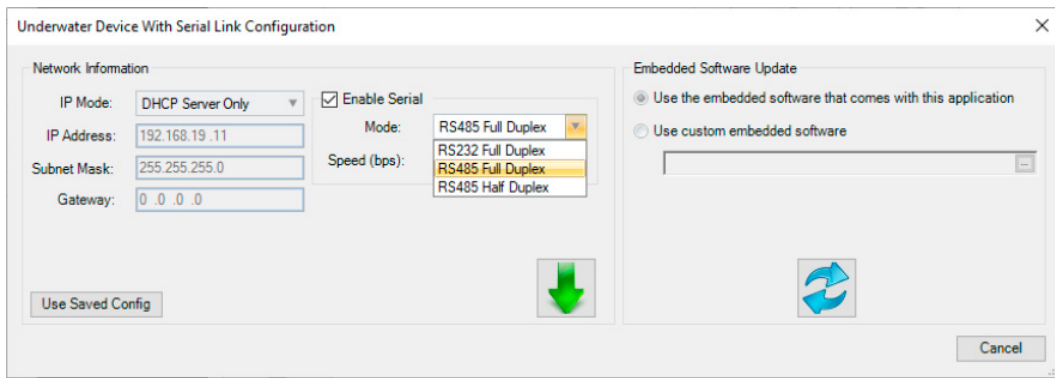

If using ethernet through the ROV, untick Enable Serial.

If using serial communications direct or through a ROV multiplexing system, tick Enable Serial, then specify protocol and baud rate using the Mode and Speed (bps) selections.

If using long umbilical cable direct from Topside Unit to U41 subsea bottle, select

To apply the changes, press the Green Arrow button. This will close the dialogue, restart the Topside Unit and show the Instrument Connection dialogue once again. There will be a delay before the Topside Unit instrument reappears in the dialogue. Press Cancel to close the Instrument Connection dialogue.

U41 subsea bottle configuration

From the Backstage/General tab, configure the U41 bottle by pressing the Connect button.

Figure 1-17 Operation with ROV - Subsea bottle configuration

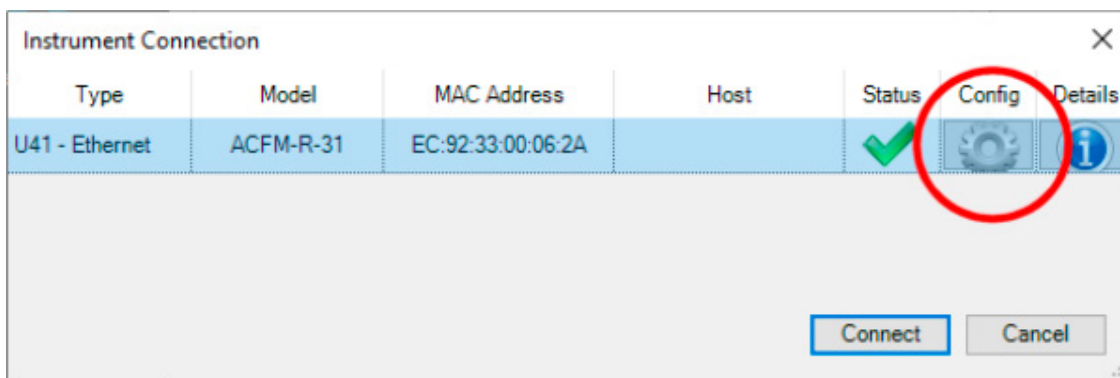

Then from the dialogue like the one shown below, select the 'U41 - Ethernet' instrument and click the Config Cog.

Figure 1-18 Operation with ROV - Subsea bottle configuration

A dialogue similar to the one shown below should appear.

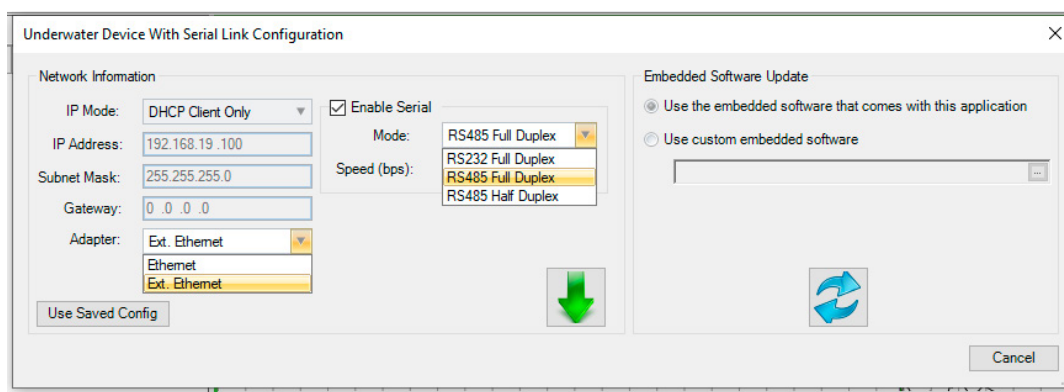
Figure 1-19 Operation with ROV - Subsea bottle configuration

If a standard ethernet connection is available through the ROV, untick Enable Serial and set Adaptor to Ethernet.

If using serial communications direct to the U41 bottle or through a ROV multiplexing system, tick Enable Serial, then specify protocol and baud rate using Mode and Speed (bps).

If using Eddyfi supplied subsea umbilical cable direct from Topside Unit to U41 subsea bottle, set Adaptor to Ext. Ethernet.

Note: If you intend to connect directly to the ASSIST PC, i.e. not via the Topside Unit, using standard Ethernet, then select DHCP Server as the IP Mode as the last configuration change here.

To apply the changes, press the Green Arrow button. This will close the dialogue, restart the U41 bottle and show the Instrument Connection dialogue once again. There will be a delay before the U41 instrument reappears in the dialogue.

If the Topside Unit has already been configured with matching serial protocols, after another delay, a second 'U41 - Serial' instrument connection method will appear similar to that shown in the dialogue below.

Figure 1-20 Operation with ROV - Subsea bottle configuration

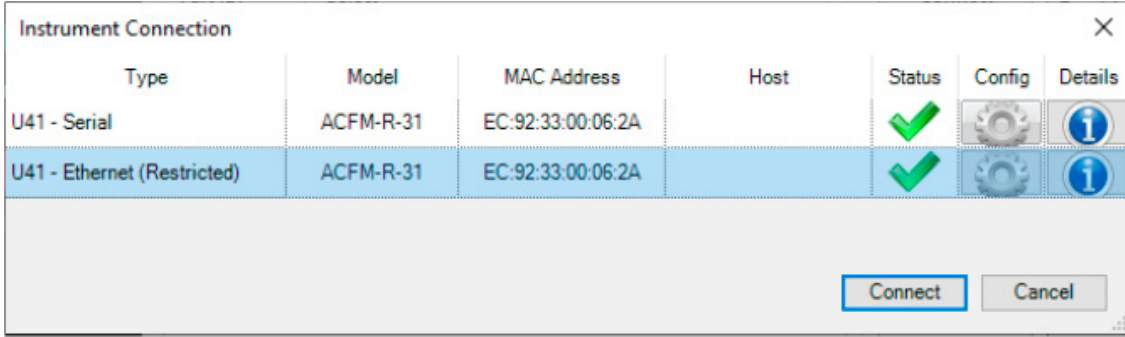

Select a connection method, then press Connect to use the selected connection, or press Cancel to return to the Backstage/General tab to configure the Topside Unit.

If Status column is not a green tick, the Details column contains an alert icon or the 'U41 -Serial' instrument connection method does not appear when expected, first wait for at least one minute for the system to finish initialisation. See example below.

Figure 1-21 Operation with ROV - Subsea bottle configuration

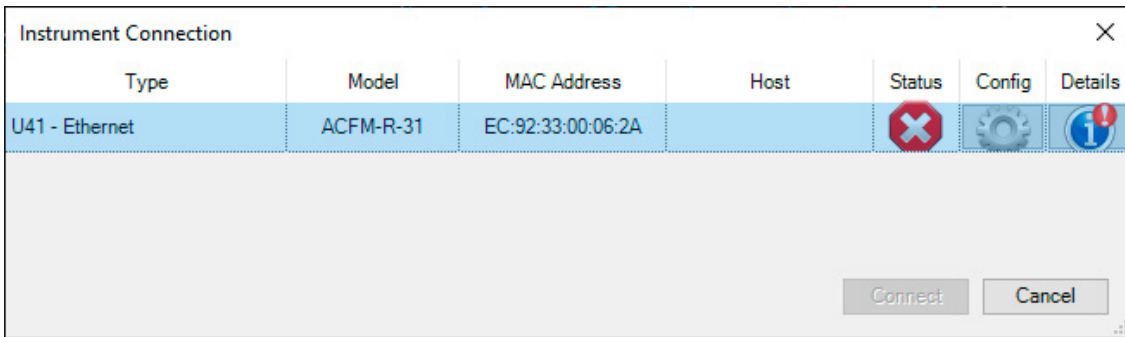

If the problem continues, check that the Topside Unit and U41 subsea bottle serial communication settings match. Also, Information about the type of problem may be found by holding the mouse over the Status, Config or Details icons or by clicking on the Details icon.

In some circumstances, the Topside Unit LEDs may be useful to diagnose problems, their behaviour is shown in the table below.

| LED | Colour | Description |
|------------------------------|----------------|---|
| ETH. EXT. | OFF | No instrument broadcast detected. |
| | Green | Extended ethernet protocol is currently used with the U41 instrument. |
| Ethernet | OFF | No instrument broadcast detected. |
| | Green | Ethernet protocol is currently used with the U41 instrument. |
| RS-232 RS-485F RS-485H | All OFF | Serial operation is not enabled |
| | One lit | Indicates which serial protocol has been selected: RS-232, RS485 Full Du-plex or RS-485 Half Duplex |
| Link | OFF | Serial link not established |
| | Blinking | Serial link not fully established |
| | Green | Selected serial link communication has been established |
| Activity | OFF | No serial data activity |
| | Blinking Green | Serial data is transferring (Tx or Rx) |

Chapter 2

The Subsea Bottle

Introduction to Subsea Bottle

The subsea bottle contains the main acquisition electronics for the system and is designed to operate at water depths up to 300m. Note there is also a larger ROV (RDW) version which is rated to 2000m.

Figure 2-1 U41 bottle - side view

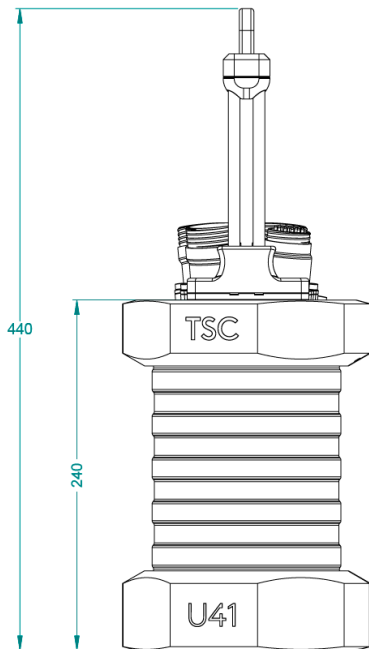
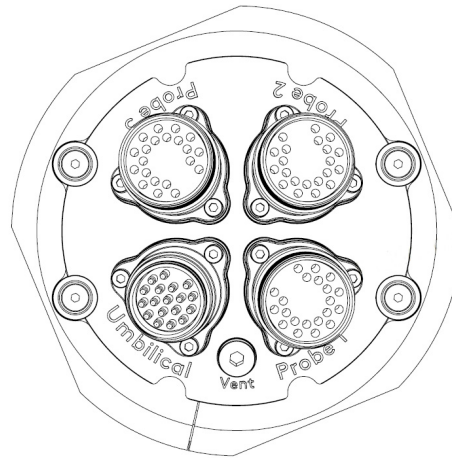

Figure 2-2 U41 bottle - top view



Subsea bottle main body. The subsea bottle body is made from hard wearing stainless steel and contains no user serviceable parts

Removable handle. The handle can be removed to aid in connecting probes and the umbilical to the bottle or for transport. To remove the handle, lift both red sliding catches where the handle meets the body and at the same time rotate the handle in an anticlockwise (counterclockwise) direction. The handle can now be lifted away. To refit the handle, place the handle over the exposed studs on the body and rotate the handle clockwise until both red catches lock into place.

Rubberized bumpers. The bumpers protect the body from general knocks and allow the bottle to be placed horizontally on a desk if required. The bumpers can be removed for cleaning by lifting the retaining clip at the split line of each bumper and peeling the bumper from the body. Note that the handle must be removed to remove or attach the top bumper. The bumpers are not interchangeable and must be refitted in the same orientation as they were removed.

Umbilical connector. The connector to which the umbilical is attached. To attach the umbilical Probe connectors (3). Three connectors are available to connect Sensu2 UW probes. Where a probe is not connected, a blanking plug must be fitted before deploying subsea.

Specifications

General specifications for Model D, DA and R

| | Model: D, DA and R | Model RDW |
|-------------------------|---|---|
| Dimensions | 44 cm x 17 cm diameter (Handle included) 29.3 cm x 17 cm diameter (Handle not included and bumper included) 29.3 cm x 14 cm diameter (Handle and bumper not included) | 47 cm x 18 cm diameter (Handle included) 32.3 cm x 18 cm diameter (Handle not included and bumper included) 31.8 cm x 15.4 cm diameter (Handle and bumper not included) |
| Weight | 9.7kg in air / 5.5kg in water | 16 kg (Not include the internal electronic. Need to be confirm) |
| Volume | 4.3 L | 5.6 L |
| Power requirement | 48Vdc, 400mA | 48Vdc, 400mA |
| Cooling | Passive | Passive |
| Communication Interface | Serial (R model only): RS-485 (Full/ Half Duplex), RS-232 Ethernet 100MB (R model only), Extended Ethernet (All model) | Serial (R model only): RS-485 (Full/ Half Duplex), RS-232 Ethernet 100MB (R model only), Extended Ethernet (All model) |

Environmental specifications

| | | |
|-----------------------|--|-------------------------------------|
| IP rating | IP68 Up to 300 meters immersion | IP68 Up to 2000 meters immersion |
| Operating Temperature | 0 - 40°C | 0 - 40°C |
| Operating humidity | 0 - 100% | 0 - 100% |
| Storage Temperature | -20 - 60°C | -20 - 60°C |
| Storage humidity | 0 - 100% | 0 - 100% |
| Pollution degree | 2 | 2 |
| Compliance | IEC 61010-1, IEC 61326-1, IEC 60945, IEC 60533, IEC 61010-1, IEC 60945, IEC 60533, CE, ICES-001, AS/NZS CISPR 22 | |

Connectors

Umbilical

The umbilical connector carries power and communications between the subsea unit and topside unit. It is a wet-mateable subsea connector which is designed to be made and broken in wet conditions topside. It should not be disconnected subsea.

The deck integration cable can be connected directly to this connector to test and configure the system before an umbilical or subsea whip is connected for deployment subsea. Ensure that the orientation of the missing pin is correctly aligned when mating the plug and socket. If the connectors are mis-aligned and the connection is forced together then damage may occur to the plug, socket or whole unit.

Figure 2-3 Umbilical connector

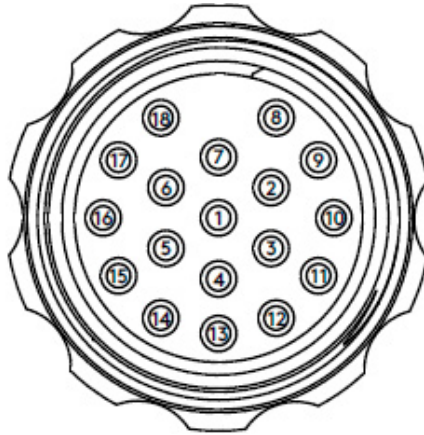

Pinout

| Pin | Signal | Description |
|-----|------------------------|--|
| 1 | Drain wire | Drain Wire |
| 2 | Extended Ethernet - | Communication over 450 meters |
| 3 | Extended Ethernet + | Communication over 450 meters |
| 4 | ETH_RX- | Ethernet Rx-. Available on R model only. |
| 5 | ETH_RX+ | Ethernet Rx+. Available on R model only. |
| 6 | ETH_TX- | Ethernet Tx-. Available on R model only. |
| 7 | ETH_TX+ | Ethernet Tx+. Available on R model only. |
| 8 | RS485TX- or RS232_RTS | RS-485 Tx or RS-232 RTS signal. Available on R model only. |
| 9 | RS485TX+ or RS232_TX | RS-485 Tx+ or RS-232 CTS signal. Available on R model only. |
| 10 | RS485_RX- or RS232_CTS | RS-485 Rx- or RS-232 CTS signal. Available on R model only. |
| 11 | RS485_RX+ or RS232_RX | RS-485 Rx+ or RS232 Rx signal. Available on R model only. |
| 12 | RS232_GND | Ground for RS232 communication. Available on R model only. |
| 13 | nSAFE_BOOT | Signal active low to boot the system in recovery mode. |
| 14 | V- | External power supply GND |
| 15 | V- | External power supply GND |
| 16 | V+ | External positive power supply, nominal voltage input is 48Vcc |
| 17 | V+ | External positive power supply, nominal voltage input is 48Vcc |
| 18 | GNDC | Chassis Ground for cable overall shield and drain wire |

Probes

Three probe connectors are fitted to the U41. These are wet-mateable subsea connectors which are designed to be made and broken in wet conditions topside. They should not be disconnected subsea.

Only SENSU2 UW probes from Eddyfi are compatible with the probe connectors and no other connection should be made as damage to the instrument may occur.

Probe connection

Each Sensu2 UW probe is terminated in a subsea connector which can be attached to any one of three probe input connectors on the U41 subsea bottle. To create a connection:

1. Orientate the probe plug with the bottle connector using the missing pins as a guide.
2. Gently insert the plug into the bottle socket and, when sure the pins are aligned correctly, push firmly down to mate the two flat surfaces of the connectors together.
3. Screw down the probe locking collar completely.

If the plug is difficult to insert, check for bent pins then lubricate the rubber parts with a light spray of silicon oil.

If any probe connector does not have a probe attached, a blanking plug must be fitted to avoid potential damage to the connector or unit.

Maintenance of the subsea bottle

Connectors

1. Clean the subsea unit with fresh water after each dive while probe and umbilical are still connected.
2. Always keep connectors on probes covered when not in use to avoid contamination - do not allow to 'dry out' by long exposure to heat and sunshine.
3. After ensuring connectors are dry, fit blanking plugs to all unused bottle, umbilical and probe connectors
4. Lightly lubricate the connector pins with silicon spray on the rubber part only.
5. Check cleanliness of contacts.
6. Use warm soapy water with cotton buds to clean female connectors.
7. Before each dive, visually check the connectors, particularly with regard to splits or mechanical damage.
8. The probe cable between the small electronics bottle and the subsea unit must not be changed in the field because the connectors will be damaged by water ingress.

Instrument and Cables

1. The subsea instrument and probes are rated to 350m water depth (except deep-water ROV version, which is rated to 2000m).
2. Avoid bending the connectors where they are attached to the subsea unit.
3. Never use the umbilical to lift the unit. A separate lift line must be used attached to the loop on top of the stainless steel handle. It is recommended that "Chinese fingers" or similar strain relief be applied between the umbilical and the handle prior to deployment. Fix the umbilical to the handle in such a way that no abrasion damage can occur and also to provide strain relief. If two 150m umbilical cables are connected together to make 300m, or 3 are connected together to make 450m, ensure that the connection is not strained by tying a rope between the two cables across the connection to take any strain.
4. Never put strain on the probe or connectors. Always use rope to tie the probe to the cage to provide strain release in case of accidental tension being applied to the cables. This also allows more than one probe to be carried on the unit. Ensure that all probe cables are coiled up and tied to the cage during deployment/recovery of the subsea unit to minimise the chances of accidental damage through collisions with the structure.
5. If the umbilical is damaged, do not use the system.

6. Do not disconnect the umbilical underwater. It is recommended that the umbilical connection to the bottle is taped up to prevent it being inadvertently disconnected. It is also recommended that the umbilical is left connected to the bottle, if possible, between dives. If the umbilical must be disconnected on deck, cover the end immediately to preclude any water ingress. Ensure a cover is kept on the subsea unit connection whenever the umbilical is not connected. Avoid all possibility of contamination by water, grit, etc.
7. It is recommended that any faults/anomalies however minor should be recorded in a technical log kept with the unit. ACFM Operators new to the equipment should then sign and date the technical log that the above has been read and acted upon.

**** IF IN DOUBT, REFER TO MANUFACTURER ****

Chapter 3

The Topside Unit

Introduction to the topside unit

The topside unit provides power and communications between the subsea unit and the controlling laptop or desktop computer. There are two models: one for use with diver-based equipment (Topside Unit - D) and one for ROV equipment (Topside Unit - R). Note that the Topside Unit - R will work with a diver subsea bottle but not vice versa.

The models are similar with the main difference being that the R version supports additional communications protocols between the Topside Unit and Subsea Unit for use with various ROV systems. The R version is shown below; the D version is visually similar except it does not include the additional communications status LEDs.

Figure 3-1 Topside unit

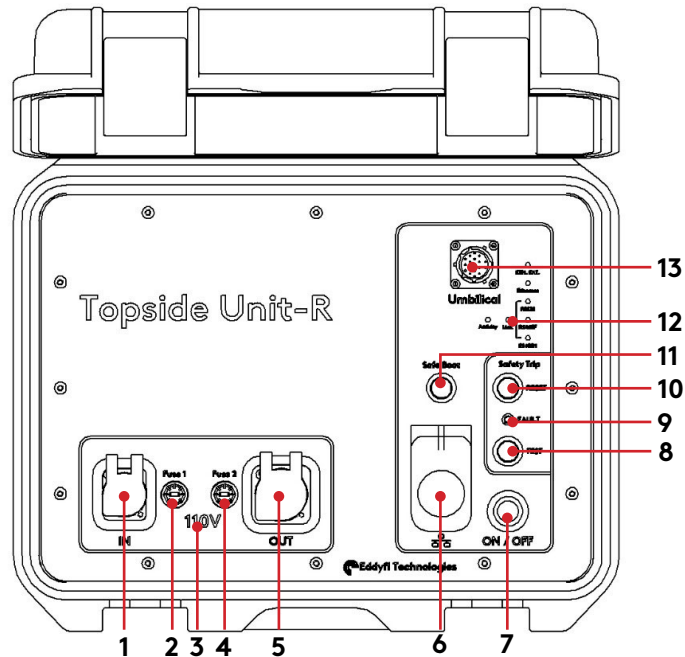

1. Power in connector. Connect the dedicated power cable, with integral RCD, to this connector by inserting the plug and rotating clockwise until the connector clicks into place. The plug has a locking mechanism to avoid accidental disconnection in use. To remove the plug, slide the catch on the barrel to unlock and rotate the plug anti-clockwise.
2. Power in Live fuse. 5 x 20mm ceramic cartridge fuse rated for 5A/250Vac, anti-surge.
3. 110V power present indicator. When there is 110-120Vac on the input connector, this indicator is lit.
4. Power in Neutral fuse. 5 x 20mm ceramic cartridge fuse rated for 5A/250Vac, anti-surge.
5. 110-120Vac power output socket. This is used to power an external laptop charger from the topside unit. The output connector is of the same family as the input power connector and works in a similar manner.
6. Ethernet connection to computer
7. Unit On/Off latching push switch with illumination when powered on.
8. Umbilical power Safety Trip Test switch.
9. Umbilical power Safety Trip Fault indicator.
10. Umbilical power Safety Trip Reset button.
11. Safe Boot button. To restore operation to a potentially corrupted subsea unit firmware, hold this button while powering on the topside unit.
12. Topside to subsea unit comms protocol indicators (R version only). These indicate the currently set protocol in use between the topside unit and the subsea bottle.
13. Integration cable connector.

Safety Trip device

The topside unit features an integral safety trip device that is designed to cut the DC power supply to the subsea bottle in the event of the umbilical being damaged or cut and exposing the power wires. The operation is similar to the RCD device in the AC power cable but whereas the power cable RCD protects the operator from AC power faults, the Safety Trip protects the diver from potential DC power faults.

The safety trip should be tested when the system is first powered on, is re-configured or at least daily. To test the safety trip:

- Press the Reset button and verify that the blue indicator on the power switch is showing.
- Press the Test button and confirm that the blue indicator is removed and the red fault light is displayed.
- Press the Reset button again and check that the red fault light is extinguished and the blue power button light reappears and remains. If this does not function, or if during operation the safety trip trips repeatedly, suspend all operations, turn off mains supply and review the advice in Safety device trips on "Safety device trips", page 58

Power-Supply cord

If another power-supply cord is used, the marked electrical rating should be at least: 120Vac, 5A.

Note: Always refer to the manufacturer's recommendations

Specifications

General specifications

| | Model: D | Model R |
|-------------------------|---------------------------------|--|
| Dimensions | 36.1 cm x 29 cm x 16.4 cm | |
| Weight | 6.4 kg | 6.4 kg |
| Volume | 12 L | |
| Power requirement | 110-120Vac \pm 10% 50/60Hz 3A | |
| Overvoltage | Category II. | |
| Cooling | Passive | |
| Communication Interface | Extended Ethernet | Serial: RS-485 (Full/Half Duplex), RS-232 Ethernet 100MB, Extended Ethernet |

Environmental specifications

| | |
|-----------------------|--|
| IP rating | Design for IP54 |
| Operating environment | Indoor or outdoor use (When adequately protected from the environment) |
| Operating Temperature | 0 - 40°C |
| Operating humidity | 0 - 95% non-condensing |
| Operating altitude | 0 - 5000 m |
| Storage Temperature | -20 - 60°C |
| Storage humidity | 0 - 90%, non-condensing |
| Pollution degree | 2 |
| Compliance | IEC 61010-1, IEC 60945, IEC 60533, NRTL, CNEMKO, CE, ICES-001, AS/NZS CISPR 22 |

Connectors

Umbilical

Figure 3-2 Topside unit - umbilical connector

Pinout:

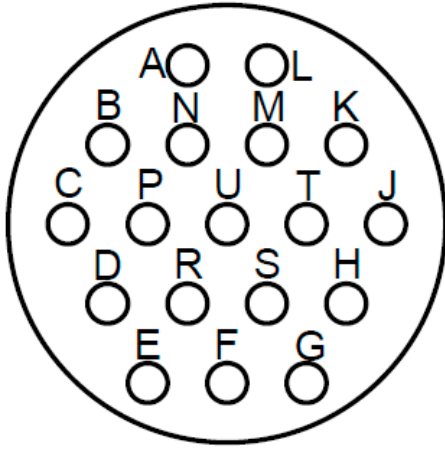

| Pin | Signal | Description |
|-----|------------------------|--|
| A | GNDC | Chassis Ground for cable overall shield and drain wire |
| B | V+ | External positive power supply, nominal voltage input is 48Vcc |
| C | V+ | External positive power supply, nominal voltage input is 48Vcc |
| D | V- | External power supply GND |
| E | V- | External power supply GND |
| F | nSAFE_BOOT | Signal active low to boot the system in recovery mode. |
| G | RS232_GND | Ground for RS232 communication. Available on R model only. |
| H | RS485_RX+ or RS232_RX | RS-485 Rx+ or RS232 Rx signal. Available on R model only. |
| J | RS485_RX- or RS232_CTS | RS-485 Rx- or RS-232 CTS signal. Available on R model only. |
| K | RS485TX+ or RS232_TX | RS-485 Tx+ or RS-232 CTS signal. Available on R model only. |
| L | RS485TX- or RS232_RTS | RS-485 Tx or RS-232 RTS signal. Available on R model only. |
| M | ETH_TX+ | Ethernet Tx+. Available on R model only. |
| N | ETH_TX- | Ethernet Tx-. Available on R model only. |
| P | ETH_RX+ | Ethernet Rx+. Available on R model only. |
| R | ETH_RX- | Ethernet Rx-. Available on R model only. |
| S | Extended Ethernet + | Communication over 450 meters |
| T | Extended Ethernet - | Communication over 450 meters |
| U | Drain wire | Drain Wire |

120Vac Power In connector

Figure 3-3 Power in connector

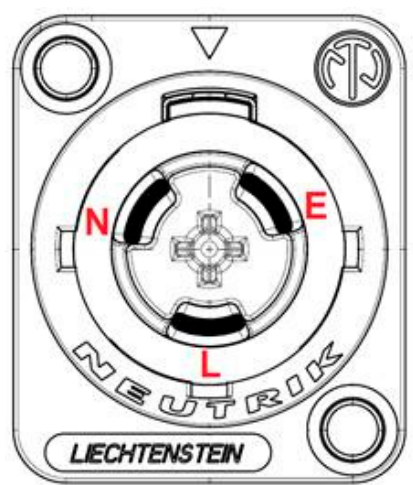

| | |
|--------------|----------------|
| Type | 3 pole locking |
| Manufacturer | Neutrik |
| Part Number | NAC3MPX |

| Pin | Description |
|-----|----------------------------|
| L | Live from the 120Vac In |
| N | Neutral from the 120Vac In |
| E | Earth |

120Vac Power Out connector

Figure 3-4 Power out connector



| | |
|--------------|----------------|
| Type | 3 pole locking |
| Manufacturer | Neutrik |
| Part Number | NAC3FPX |

| Pin | Description |
|-----|-------------------------|
| L | Live from the 120Vac In |
| L | Live 120Vac Out |
| N | Neutral 120Vac Out |
| E | Earth |

Ethernet Connector

The Ethernet connector is used to connect the Topside unit to a PC or network through an Ethernet link. Eddyfi supplies a high-quality Ethernet connector and cable which includes a locking connector. International Ethernet standards are used and any good quality CAT5 compliant cable can be used if required.

Figure 3-5 Ethernet connector

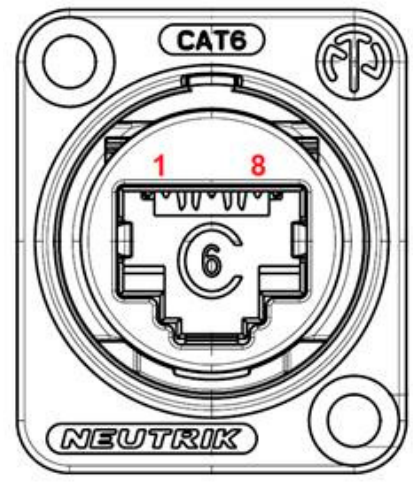

| | |
|--------------|--------------|
| Type | RJ45, female |
| Manufacturer | Neutrik |
| Part number | NE8FDY-C6-B |

| Pin | I/O | Signal | Description |
|-----|-----------------|--------|--------------|
| 1 | Transmit Data+ | TX+ | Ethernet Tx+ |
| 2 | Transmit Data - | TX- | Ethernet Tx- |
| 3 | Receive data+ | RX+ | Ethernet RX+ |
| 4 | - | - | |
| 5 | - | - | |
| 6 | Receive data- | RX- | Ethernet Rx- |
| 7 | - | - | |
| 8 | - | - | |

Maintenance of the topside unit

There are no user serviceable parts inside the topside unit and the top panel should not be removed as this will invalidate the warranty.

The topside unit is water-resistant to IP54 when in use (i.e. with the lid open but all connections made). However, care must be taken not to get water into the connectors or sockets when connecting the umbilical cable, mains power or comms cable to the supporting computer. Note that the computer itself may not be water-resistant (refer to manufacturers manual if in doubt).

The topside unit must be powered from 110-120Vac 50/60Hz mains supply voltage. If it is being run from a generator, check that the supply voltage remains in the range 100 to 120V.

Warning: Supplying power to the topside unit outside this range will invalidate the warranty and may damage the unit.

Avoid bending the connectors where they are attached to the topside unit.

Cleaning instructions

The topside unit external surfaces (i.e., casing and front panel), can be cleaned when necessary. This section explains the procedure to clean the instrument appropriately. To clean the instrument:

1. Make sure that the instrument is off and that the power cord is disconnected.
2. To bring the instrument back to its original finish, clean the casing and the front panel with a soft cloth.

Warning: Do not clean the instrument with a spray or water jet.

To remove stubborn stains, use a cloth moistened with a soft soapy solution. Do not use abrasive products or powerful solvents as they can damage the finish. Wait until the instrument is completely dry before connecting the power cord and cables.

Chapter 4

Assist3 Software

Introduction to Assist3 software

The latest version of TSC's ACFM data collection and analysis software is known as Assist3. It is available in several versions to support different instruments and customer needs but all versions are built on the same user friendly interface so switching between them is easy.

The version capabilities are as follows:

| | |
|------------------|---|
| ASSIST Go | Embedded software in AMIGO2™ instrument |
| ASSIST Pro | Desktop software which can connect to an Amigo2 from a separate computer and acquire data remotely |
| ASSIST Pro Diver | Desktop software which can connect to a U41D from a separate computer and acquire data remotely. Note that this version can also connect to an Amigo2 for data acquisition if required |
| ASSIST Pro ROV | Desktop software which can connect to a U41R from a separate computer and acquire data remotely. Note that this version can also connect to a U41D and an Amigo2 for data acquisition if required |
| ASSIST CP | Desktop software used for offline data analysis and report generation. This version does not connect to any instrument for data acquisition |

The Amigo2 uses the embedded ASSIST Go on the actual instrument which is operated through the touchscreen and surrounding buttons. The Amigo2 can also be operated remotely using a Windows PC or laptop running ASSIST Pro.

The U41 system uses either ASSIST Pro Diver or ASSIST Pro ROV (depending on the system) installed on the desktop of a Windows PC or laptop.

ASSIST Pro can be run without an instrument attached for the review and analysis of data but there is also a version, ASSIST CP, which allows review, analysis and reporting but cannot acquire data from an instrument.

ASSIST is split into the frontstage and backstage. The frontstage is used to collect and analyse ACFM data. The backstage is primarily used to enter job details, manage probe configurations, settings and files. The software opens on the backstage.

Pressing either the blue or red arrow button at the top left of the screen toggles between the two. Pressing the **Start/Resume** button at the bottom of the backstage screen also takes the user from the backstage to the frontstage.

Backstage

The backstage consists of four tabs running down the left-hand side.

- **General.** Enter job details, import and export data, manage probe configuration files, etc.
- **Documentation.** View PDF documents relating to the software.
- **Preferences.** Change system settings, units, time and date, connect to wireless networks, etc.
- **Help.** Software, firmware versions and license information, etc.

The four sections are described in more detail, below.

General

Figure 4-1 Backstage view: General

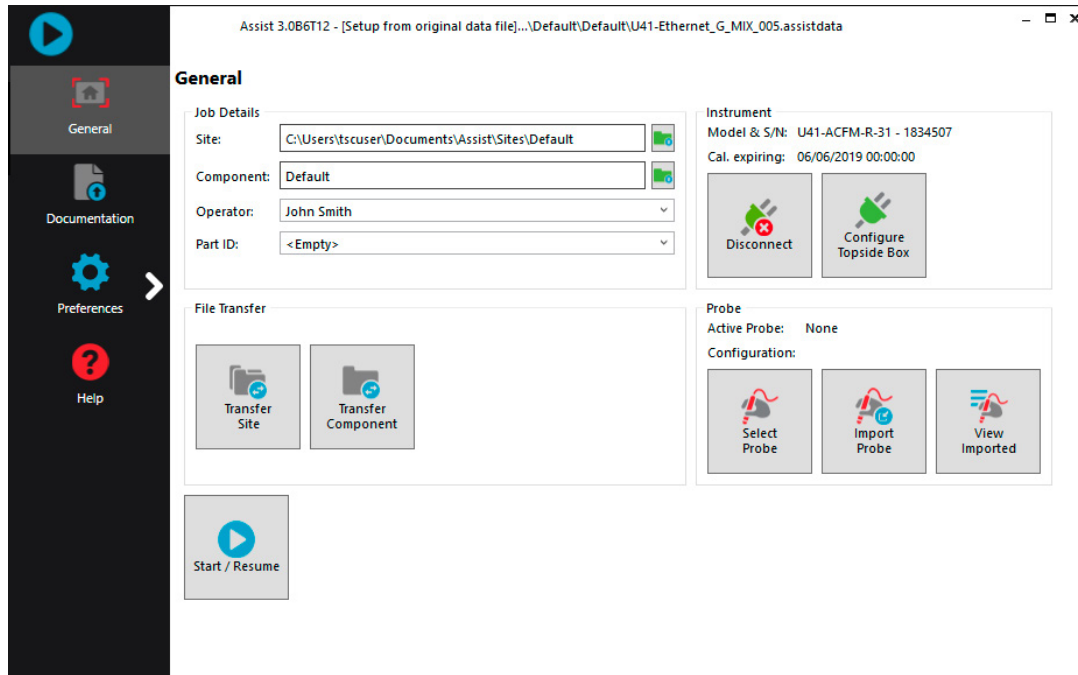

Job Details

To configure a job, values for **Site**, **Component** and **Operator** name should be entered here.

- **Site** refers to the site or location where the inspection is carried out. This may also be a job or workpack reference.
- **Component** may refer to a larger structure or assembly that has multiple inspection areas, such as a vessel, line, tank or vehicle. These names will be used in following inspections.
- **Part ID** could be a subcomponent name or weld ID which would identify the specific location of a series of inspection scans.

Your work is automatically saved so there is no need to create files and folders. Instead, the system will use these labels to automatically create files and folder names for you. For this reason, it is worth entering these labels in a full and formal manner. The operator's name will be appended to any reports which are automatically generated by the system, so it's best to use your full name.

Instrument

Once a connection is established with the instrument, the model, serial number and calibration expiry date are shown here. **Connect/Disconnect** and **Configure Topside Box** enable a communications link to be established between the software and instrumentation hardware.

Connect/Disconnect

Many operations can be performed in ASSIST without the instrument hardware, such as data replay, analysis and reporting. However, to perform inspection requires a connection to the instrument.

Connection to instruments is usually via a standard RJ45 CAT5 style LAN cable directly from the computer to the instrumentation, but different configurations are possible. By default, software and hardware is supplied configured for this mode of operation.

Press **Connect** and a dialogue similar to the one shown below should appear.

Figure 4-2 Connect/disconnect

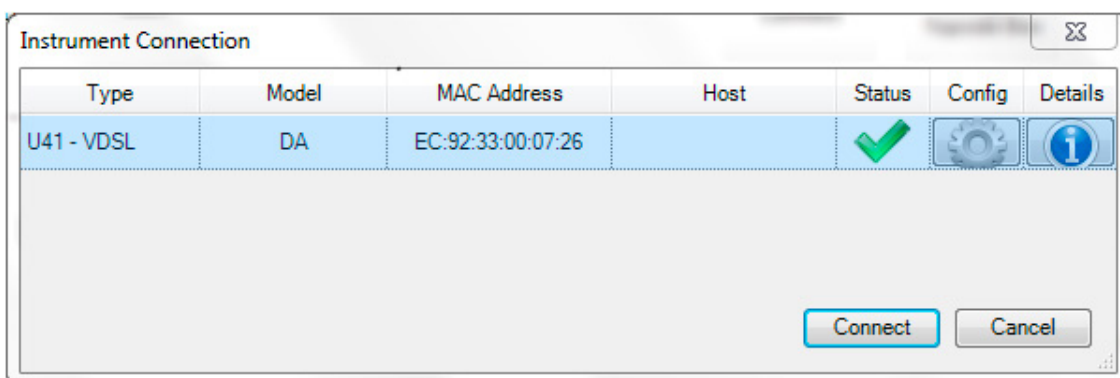

Wait for the status to show a green tick, click/select the instrument name and press **Connect**.

When the instrument is no longer required, press **Disconnect**. If the instrument is powered off or the link broken, the system will automatically disconnect.

For more advanced configurations, see the relevant sections of the instrument manual.

Select Probe

Up to three probes can be attached to the instrument at any one time. The selected Active Probe and its selected active Configuration are shown here.

The **Select Probe** button allows you to choose which probe and configuration to use. This function can also be accessed from the **Backstage/General** tab or the **Home Ribbon**, as described on "Home ribbon", page 40.

Figure 4-3 Select probe

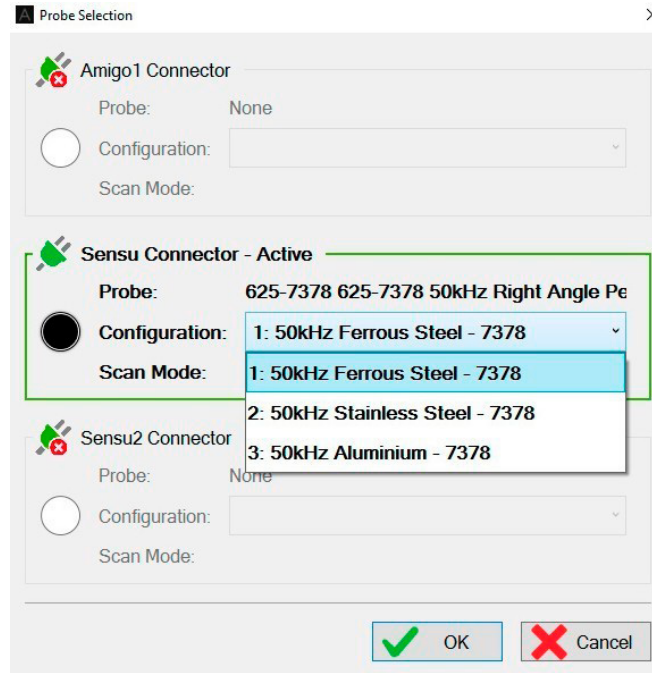

Probe selection

Some ACFM probes are calibrated for more than one material. If this is the case, the material **Configuration** can be selected from the list. The **Scan Mode** can be set to clock or encoder (if you have an encoder fitted). In clock mode it takes several readings a second, regardless of whether the probe is moving. In encoder mode it only gathers data when the probe is moving, then displays the data against distance travelled. Before scanning can start, a connector and probe must be selected as **Active**.

Import Probe is used to import probe configurations for legacy probes when used with a PC U41 does not support legacy probes and this option is not used on the U41 system. When using ASSIST Pro with an U41 instrument, which does support legacy probes, this will copy Amigo1 probe configuration files (.qpc) found on the root of a USB mass storage device to the ASSIST probe library. This only needs to be done the first time an Amigo1 probe is used on the instrument, or if a configuration file is changed. In this case the current configuration file will be overwritten.

View Imported displays all the imported configuration files and allows you to delete any that are no longer required. For example, if you were installing a new version of the file. Probe files can be deleted by selecting the relevant item in the list and press the red cross.

Figure 4-4 View imported probes

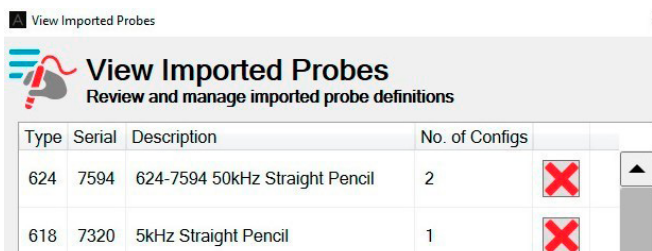

File Transfer

Transfer files between the program and a USB mass storage device. Files can also be deleted using this function. A new file or “page” of data is created every time **Run** is pressed. Files are collected in subfolders labelled by **Component** name, which are collected within top level folders labelled by Site name. The filename for each page is based on the **Part ID**, the type of **Scan** (function check [F] or general [G]), the Line (toe 1, weld cap, HAZ, etc) and page number. For example:

Part ID F TO1 001A Function Check on toe 1, page 1.

Part ID G CAP 002A General inspection scan on the cap, page 2.

Part ID G HAZ 003A General inspection scan on the HAZ, page 3.

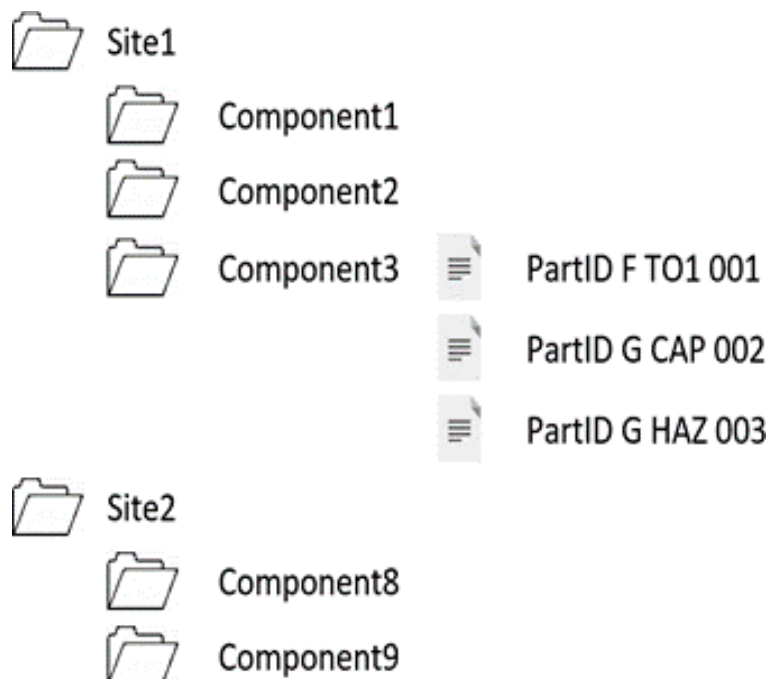

Files can be transferred at the component level or the site level, in which case multiple components, contained within the “Site” folder can be transferred simultaneously.

Start/Resume

Takes the user to the frontstage.

Documentation

This section of the backstage allows you to open and read PDFs located in the **ASSIST\UserData** folder.

Figure 4-5 Backstage view: Documentation

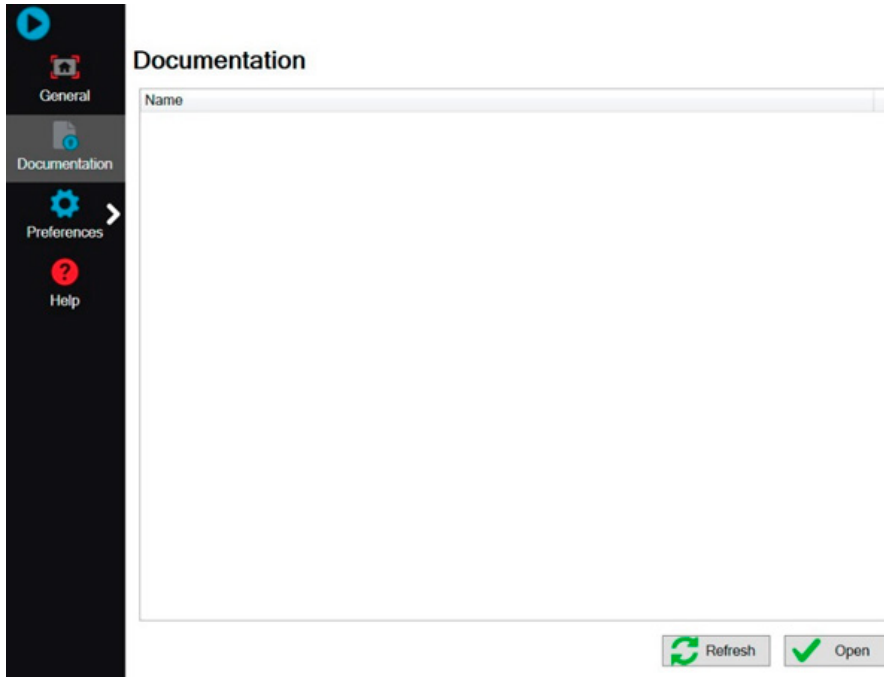

Preferences

The preference section consists of two tabs, **System** and **Display**. **System**: used to change units, company logo, date and time, wireless interfaces, **Keyboard shortcuts**.

Figure 4-6 Backstage view: Preferences/System

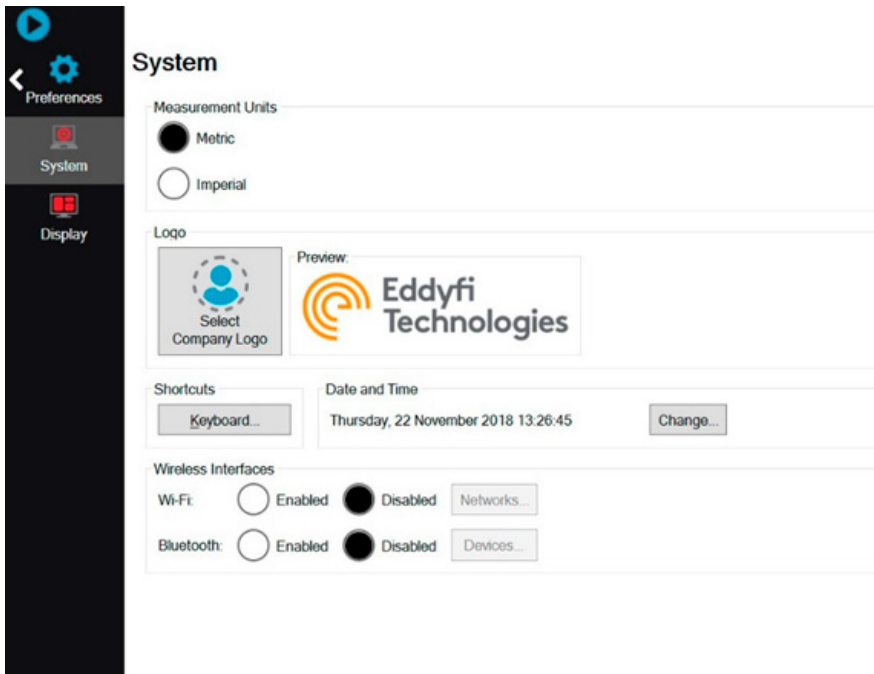

System

Measurement Units

You can use Assist3 under the US Customary (imperial) or metric system of measurement units. To change the measurement unit system, select **Imperial** or **Metric** as appropriate. When you do, measurement units are adjusted across the software and in your reports.

Company Logo

You can select an alternative image to use on reports to replace the default Eddyfi logo. If you are using ASSIST Go on the Amigo2:

1. On a USB stick, create a folder in the root called "ASSIST\UserData". Copy your logo file into this folder.
2. Plug the USB stick in the QUICK COPY USB port of the Amigo2.
3. Press the **QUICK COPY** button on the side of the Amigo2.
4. Tap **Select Company Logo**.
5. Select the logo file, and then tap **OK**.

Figure 4-7 Company logo



If you are using a version of ASSIST on a PC:

1. Click the **Select Company Logo button**. The default location is a folder named ASSIST\UserData.
2. Navigate to the folder containing the desired image file.
3. Select the logo file, and then tap **OK**.

Display

A dark color scheme uses a black background, while a light color scheme is white (note that the white scheme is best for viewing in bright sunlight while the dark mode may be useful when viewing in dim conditions). Screen brightness and auto power down can also be adjusted from this menu.

Figure 4-8 Backstage view: Preferences/Display

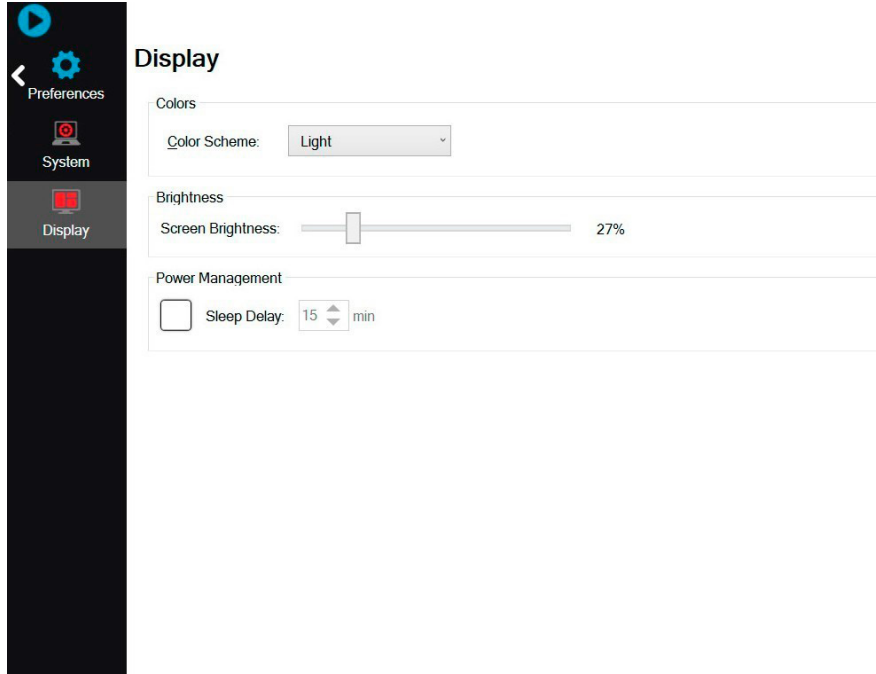

Help

Software, firmware version and license information are available here as well as the company contact details, license agreements and **Privacy Options**. In the event of a malfunction, the log can be transferred to a USB mass storage device for diagnosis.

Figure 4-9 Backstage view: Help

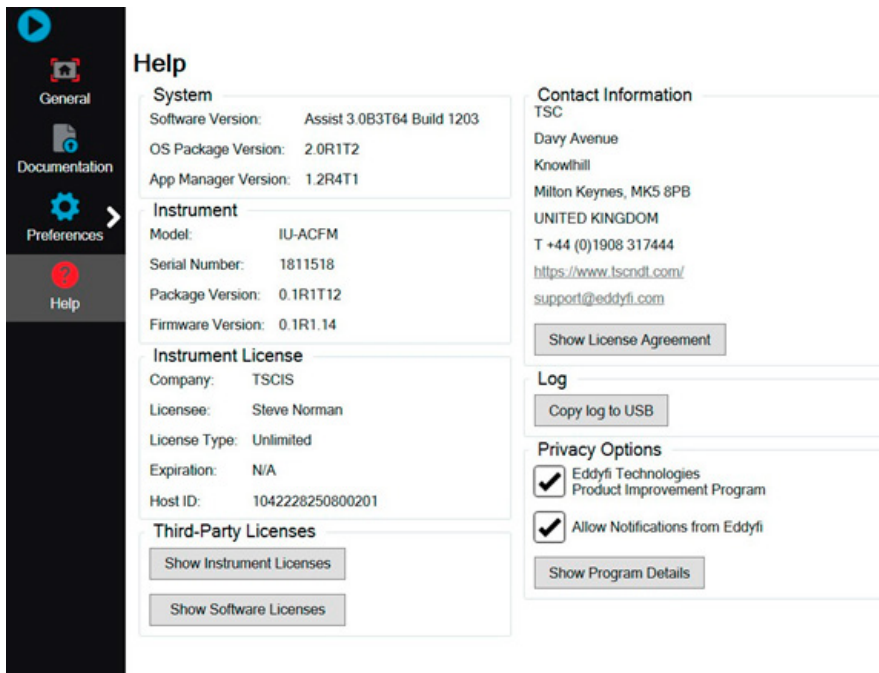

Frontstage

Layout

The frontstage consists of the ribbon zone, side tabs, main data zones, bottom tabs and information bar.

Figure 4-10 Frontstage layout



The Data views can be specified in the Layouts Ribbon. A Standard Layout is shown below. The frontstage can be further broken down into the following elements:

Figure 4-11 Frontstage screen

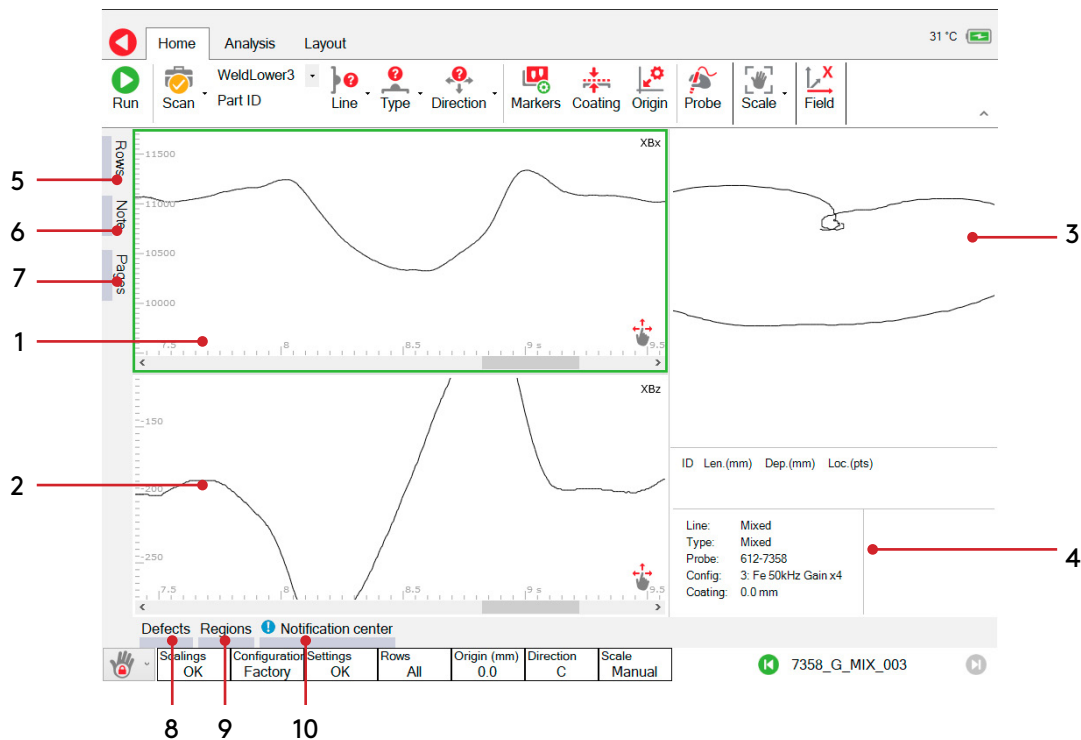

1. **Bx trace.** Top left. Use left-click and mouse move (or single finger drag on a touchscreen) to both pan the Bx data scale and scroll the x-axes when zoomed. Use right-click and mouse move (or two finger spread on a touchscreen) to select and zoom-in on x-axes. Use right-click and select an appropriate menu option (or two finger pinch on a touchscreen) to zoom out.
2. **Bz trace.** Bottom Left. Use left-click and mouse move (or single finger drag on a touchscreen) to both pan the Bz data scale and scroll the x-axes when zoomed. Use right-click and mouse move (or two finger spread on a touchscreen) to select and zoom-in on x-axes. Use right-click and select an appropriate menu option (or two finger pinch on a touchscreen) to zoom out.
3. **Butterfly plot.** Top right. Use left-click and mouse move (or single finger drag on a touchscreen) to pan the Bx & Bz data scales. Use Shift with left-click and mouse move (or two finger pinch on touchscreens) to adjust the size of the butterfly loop. Note that this action changes the view scalings.
4. **Information pane.** Bottom right. Contains information relating to the current page of data, including defects recorded, scan information and notes.
5. **Rows:** changes the row visibility of array probes. See "Row Visibility Tab", page 43 for more details.
6. **Notes:** Append a note to the current page of data using the popup soft keyboard or add a USB keyboard if required.
7. **Pages:** View pages (files) in the current work folder. Successfully recorded pages begin with a grey tick mark. Pages containing a sized defect are marked with an orange circle around a tick mark. The whole row is highlighted for the current page. Pages can be filtered, sorted and deleted. Previous or next pages can be viewed by pressing the left and right keys at the bottom right corner of the screen.
8. **Defects:** information related to defects sized on the current page. To size a defect, see "Size", page 45.
9. **Regions:** information related to regions added to the current page, and any associated comments. See "Regions List Box", page 47 for more details.
10. **Notification centre** displays system errors, etc.

Pinning side and bottom tabs

The Rows, Notes, Pages, Defects, Regions and Notification tabs can be fixed in place by pressing the pin symbol at the top right corner of the dialogue box.

Keyboard Shortcut Keys are available to automatically open-and-pin (and in some cases auto-close) the tabbed dialogs.

Figure 4-12 Pin tabs

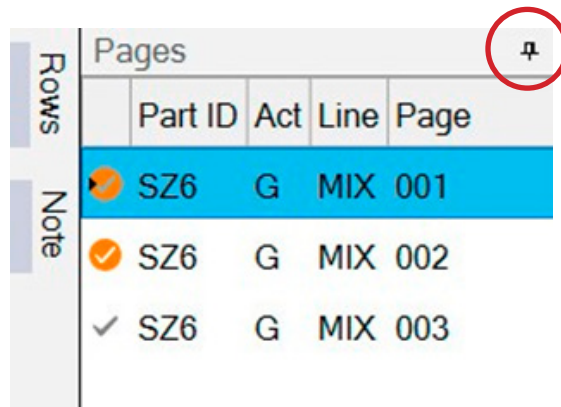

Information bar and warnings

A number of information fields run along the bottom of the screen. Any that are suboptimal are highlighted.

Figure 4-13 Information bar and warnings

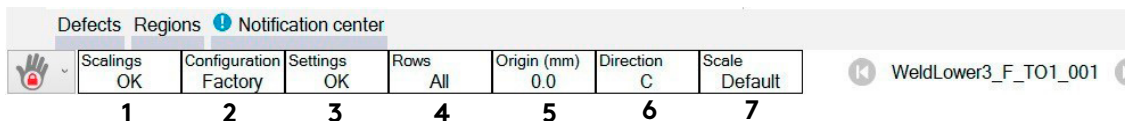

1. Scalings OK/Scalings Lost. If the scale is not the same as the probe configuration's default, the Scalings Lost warning appears to warn the operator that the screen scaling has been changed and the current signals may give a false impression of defect size.
2. Configuration Factory/Custom or non-factory. The selected probe configuration has or has not been approved for use by the manufacturer.
3. Settings OK/Settings modified. The current setting are/are not recommended by the manufacturer.
4. Rows All/3–8. Some of the rows of an array probe may be hidden. In this example, rows 3–8 are visible.
5. Origin 0 (mm)/22 (mm). If an encoder is used, the origin has been set to a non-zero position. In this example the origin has been set 22 mm from the datum.
6. Direction: The scan direction for the current page. Clockwise, Anticlockwise or Transverse.
7. Scale:
 - Default. The screen scaling is being set to the default specified for the current probe configuration.
 - Fit. The data is being scaled to fit neatly on the screen.

WARNING! Large defects may look smaller than they actually are, also small defects may look larger than they are! The Scalings Lost message will be visible.
 - Center. The data is being centered on the screen.
 - Manual. The position and scale of the data have been set manually. If the scale has been changed, the Scalings Lost warning message will be visible.

Home ribbon

The Home Ribbon contains the commands necessary for acquiring data.

Figure 4-14 Home Ribbon

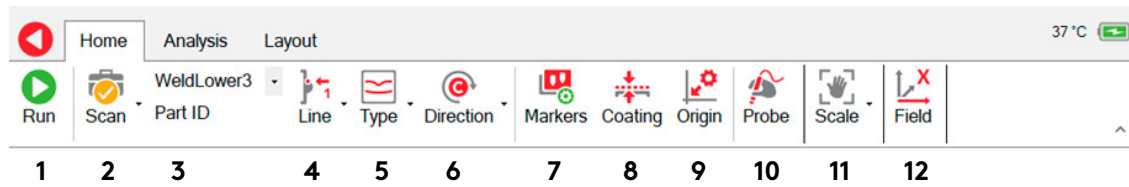

1. **Run** begins data collection.
2. **Scan** function. Function check or general scan.
3. **Part ID**. This would typically be a sub-component or weld ID.
4. **Line** position (HAZ, Weld Cap, Toe1, etc). This is an optional setting which can be used to identify and record where on the part the scan will take place (e.g. on the toe, cap, HAZ etc..)
5. Scan **Type**. This is an optional setting which can be used to identify and record the intended reason for the scan (e.g. if it is for detection, sizing etc.):
 - Function check. Used to check functionality of equipment.
 - Ops check. To locate gross defects.
 - Detection. Typically along the toes of welds
 - Cap. Detection scan along cap.
 - Mixed. One or more of the current scans combined onto one page.
 - Depth. Depth scan for sizing.
 - Parallel scan. Typically through the HAZ.
 - Zigzag. Zigzag scan to determine position of crack on the weld.
 - Sizing. Sizing scan to locate the ends of the crack.
 - Sizing check scan. Used to check the accuracy of the sizing scan.
6. Scan **Direction** (Clockwise, Anticlockwise or Transverse).
7. Configure **Markers**. See "Configuring Markers", page 42 for more details.
8. Enter the **Coating** thickness if it's non-zero. This will be automatically taken into account if any defects are sized.

Figure 4-15 Coating thickness dialogue box

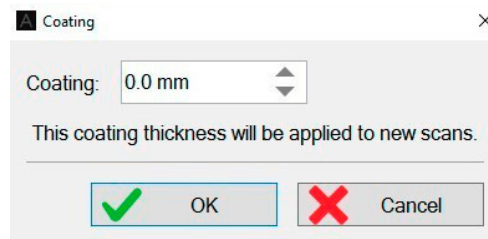

9. Enter an **Origin** distance and select an automatic end-of-scan increment if required. This is described in more detail on "Origin Dialogue Box", page 43.
10. Select a **Probe** and configuration. This is described in more detail on "Probe selection", page 32
11. The screen data **Scales** can be adjusted, as described on "Scale mode to Fit", page 52.
12. Once the data has been collected, the X and Y-field data can be toggled by pressing the **Field** button.

Scanning ribbon

The following commands are available during data collection:

Figure 4-16 Scanning ribbon

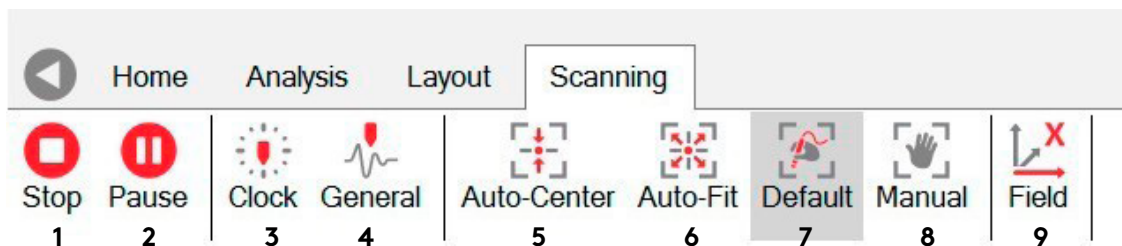

1. Press **Stop** to end data collection.
2. **Pause**. Pauses the data collection. Press Resume to resume scanning.
3. **Clock/Linear**. Adds clock or linear marks to the data. A series of sequentially numbered vertical lines corresponding to the numbered clock positions running around the circumference of a pipe or tubular, or linear positions on a flat surface. These can be configured in **Home>Markers**, as described on "Marker setup", page 52 These must be configured before pressing "Run".
4. **General**. Adds a series of unnumbered purple vertical lines to the data.
5. Screen Scale **Auto-Center**. This will display the data automatically centred in the display view. Note that this does not alter the display range, only shifts the background value.
6. Screen Scale **Auto-fit**. This option automatically fits the data to the display view so that all of the data can be seen. Note that this will change the visual scale range and a warning "Scalings Lost" will be shown in the status bar. Taking new scans in this mode is not recommended as the scale will continuously shrink or expand depending on the data. Defect indications may therefore look much larger or smaller than they should appear when using normal scales from the probe configuration.
7. Screen Scale **Default**. This will return the data display scales to the default levels set in the probe configuration.
8. Screen Scale **Manual**. This mode is set when the scales are adjusted manually by using the cursor keys (or a single finger swipe on touch screens) to alter the general level in the display and/or when the scale range is adjusted manually.
9. X and Y **Field** can be switched during data collection.

Configuring Markers

Pressing the physical A/C button on the left-hand side of the case, while the instrument is collecting data, adds a series of sequentially numbered vertical lines to the Bx and Bz traces. For example, if the inspector was inspecting a circumferential weld marked up in clock positions running from 1 to 12 o'clock, 12 being top dead centre, the data could be marked up accordingly. When the probe passes over one of the clock marks, the operator would press the A/C key to mark the region of data corresponding to the marked position. The exact sequence of numbers is configured in the Marker Setup dialogue box, found in Home/Markers.

Figure 4-17 Marker setup dialogue box

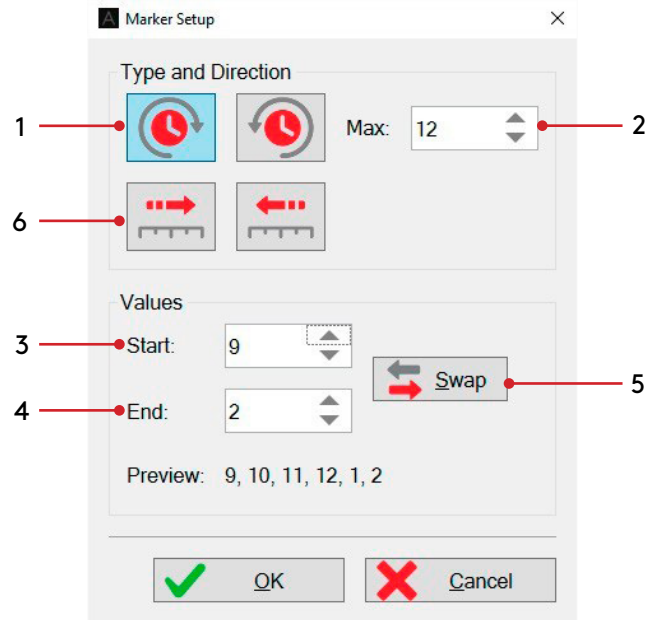

The default settings assume you are starting at 1 o'clock and ending at 12 o'clock. However this may not be the case. For example, you may be starting at 9 o'clock, scanning through 12 o'clock and ending at 2 o'clock. In this case you would want the markers to run in the following sequence: 9, 10, 11, 12, 1, 2. For this configuration you would require the following settings:

1. The numbers are increasing clockwise. This should not be confused with a probe moving in the clockwise direction.
2. The maximum number in the sequence is 12.
3. The sequence starts with 9.
4. The sequence ends with 2.
5. If the operator then wanted to reverse direction and scan from 2 o'clock, through 12 and end at 9 o'clock, they would simply press the "Swap" button to reconfigure the markers.
6. If the operator was inspecting a linear weld, rather than a circumferential weld, then the numbered sequence would not repeat in a rotational manner. In this case the markers would be configured to either increase 9, 10, 11, 12, 13, 14... Or decrease: 9, 8, 7, 6, 5...

Origin Dialogue Box

Configure next scan Origin. To allow correlation of inspection data to real world datum. Enter the offset from datum in the Origin field, or press 'Use Current' button to copy the origin value of the current page. Press OK to save changes.

The new origin value will be applied for next and subsequent scans and represents the origin value for the first data point of the page. If you have an encoder, the system can update the origin automatically at the end of the scan by calculating where the last scan stopped and assumes that scanning starts from the same position.

Figure 4-18 Origin dialogue box

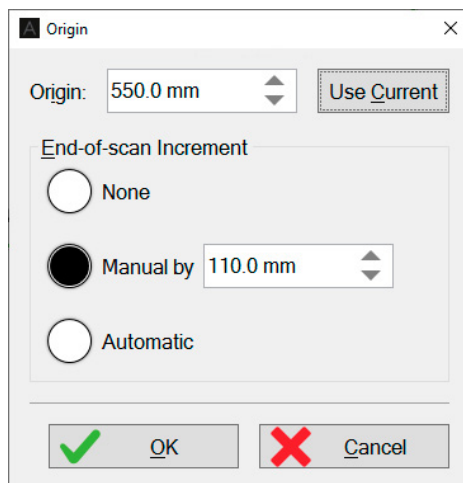

Row Visibility Tab

When viewing array probe data in the traces layout, each row of the array probe consists of a color-coded signal. When many rows are present, the multiple signals can obscure small features in individual rows. The "Rows" tab, shown below, allows the user to hide selected rows to more clearly see features in one or more rows. Dragging the blue slider ends reduces or increases the number of rows visible, while the blue slider can be moved up or down to select the desired range of the visible rows. The same can be achieved using the red buttons within the dialog.

Figure 4-19 Row Visibility Tab

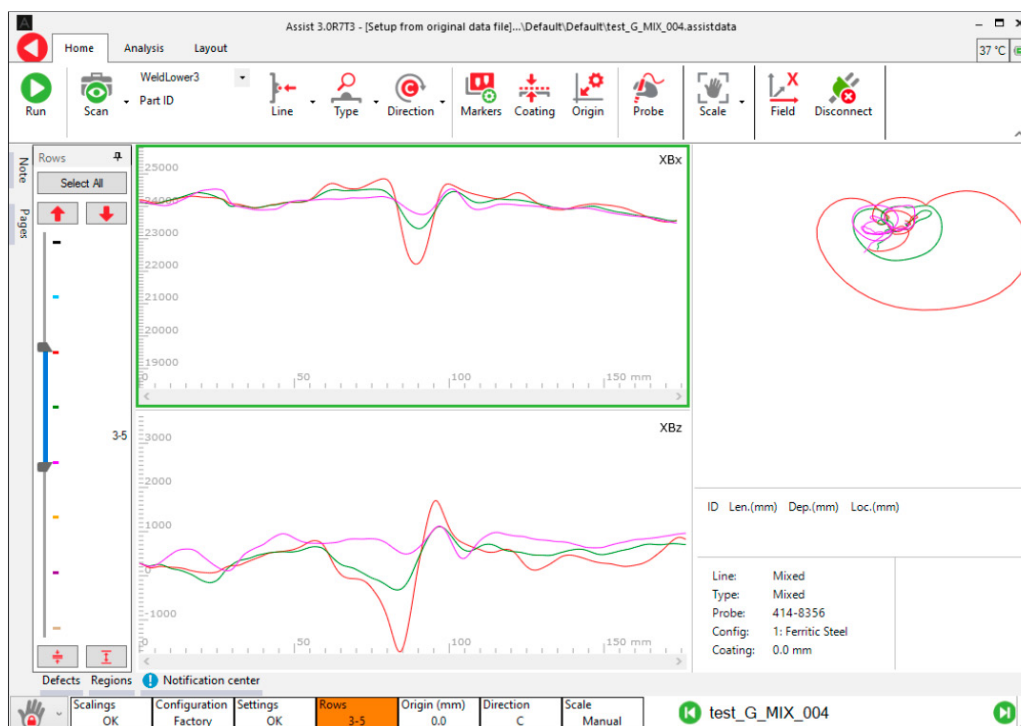

Analysis Ribbon

Once data has been collected it can be analysed.

Figure 4-20 Analysis ribbon

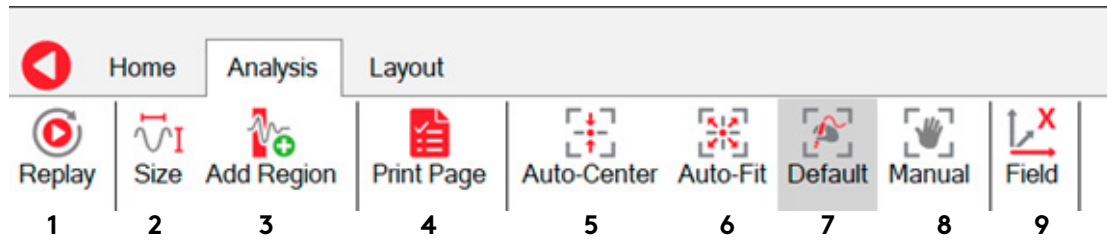

1. **Replay** displays the collection of the current page of data as if it were a movie playback. The replay can be stopped, paused and displayed slower or faster using the Replay Ribbon, see "Replay Ribbon", page 44.
2. **Size** is used for measuring the length and depth of an indication see "Size", page 45.
3. **Add region** is used to highlight sections of data see "Adding a Region", page 47.
4. **Print Page** creates an automated one-page report for the current page of data see "Creating an Automated Report", page 48
5. **Auto-Center** centers the signals in the middle of the screen, without changing the screen scalings.
6. **Auto-Fit** centers the data then changes the screen scaling, so the data fills the screen without exceeding its borders. Warning! Large defects may look smaller than they actually are, also small defects may look larger than they are. Signals are shrunk or expanded to fit inside the screen boundaries. If this is the case, the Scalings Lost indicator will be activated.
7. **Default** uses the screen scalings specified in the probe's configuration file.
8. **Manual** scaling allows the user to readjust the position and size of the signals by pinching and swiping the touchscreen. This mode is automatically activated when any of the signals are touched. **Warning!** Large defects may look smaller than they actually are, also small defects may look larger than they are. If this is the case, the Scalings Lost indicator will be activated.
9. **X and Y Field** toggle. Toggle between the X and Y-field.

Replay Ribbon

The Replay ribbon becomes active when replaying data are used. It allows the user to adjust the replay display.

Figure 4-21 Replay Ribbon

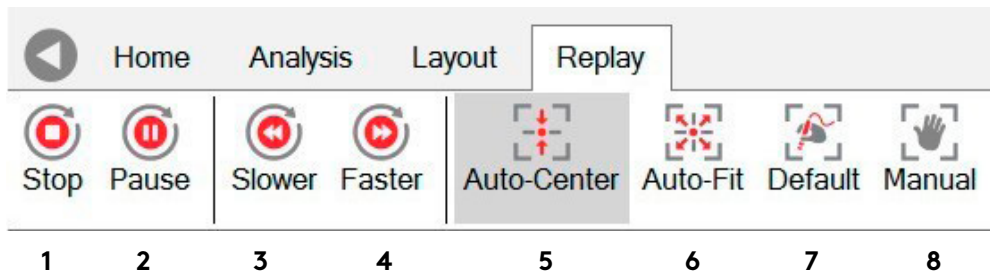

1. **Stop**. Stops the replay and returns to the previous ribbon
2. **Pause**. Temporarily pauses the scan. Press Resume to resume playback.
3. **Slower**. Decreases the playback speed
4. **Faster**. Increases the playback speed
5. **Auto-Center**. Sets the display scalings to auto center the data in the screen
6. **Auto-Fit**. Sets the display scalings to auto fit the data to the screen
7. **Default**. Sets the display scalings to the probe defaults
8. **Manual**. Freezes the scales to the current manual setting

Size

Once a defect indication has been found, it can be sized using this option from the Analysis Ribbon.

Figure 4-22 Sizing

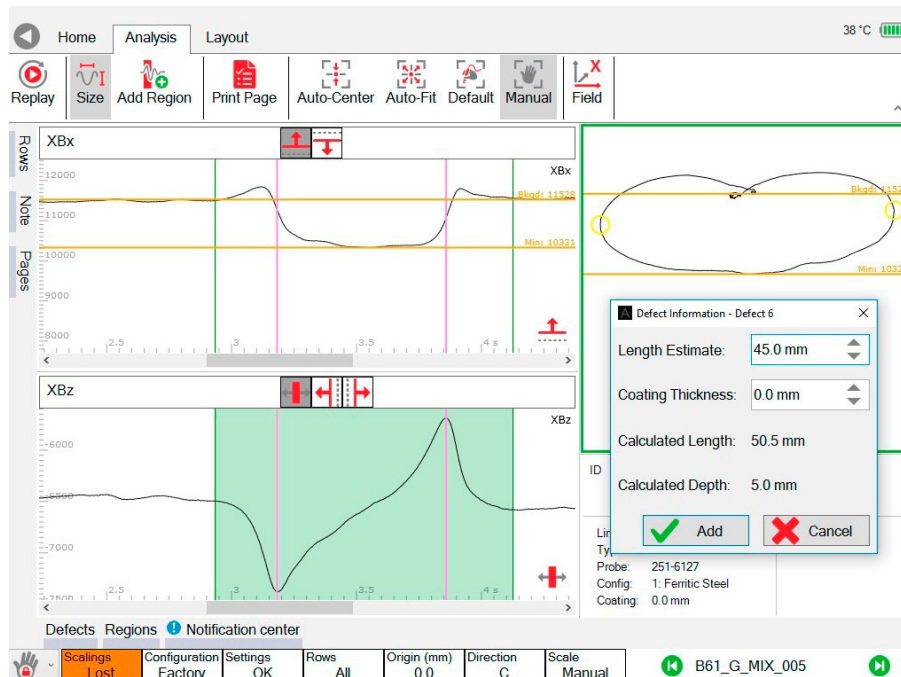

1. The **Size** button brings up the defect information dialogue box.
2. You may need to move the defect dialogue box to one side so the Bx and Bz signals are visible.
3. The defect data is selected by left-click and mouse move across the Bz trace. This is shown in green. The recommended place to start the selection is at a point just before the Bz signal begins to deviate from the background value indicating the start of the defect.
4. The recommended place to end the selection is just after the Bz signal rejoins the background at the end of the defect.
5. If this is done correctly, the Bx background value (yellow horizontal line labelled "Bkgd") will be in approximately the right position. It can be manually adjusted by dragging the yellow line with mouse (or finger on touchscreens) or for very fine adjustment using the left/right arrow keys after selecting the Bx view.
6. The Bx minimum value (yellow horizontal line labelled "Min") can also be adjusted by dragging the yellow line with mouse (or finger on touchscreens) or for very fine adjustment using the up/down arrow keys after selecting the Bx view .
7. The Bz peak and trough can be adjusted by dragging the green vertical lines or for further adjustment by pressing the button consisting of a red vertical line and arrows pointing to the left and right.
8. Enter the **Length Estimate** in the defect dialogue box.
9. Check the Coating Thickness is correct.
10. Add the sized defect to the defect list, if it is satisfactory, or press Cancel to clear the current sizing and start again.
11. This defect can be edited by pressing the **Defects** tab. "Defect List Box", page 46 for more detail.
12. The length and depth summary is added to the information pane.

Defect List Box

The defect list box includes the Part ID, line type, estimated length (Bz peak/trough distance), coating thickness, calculated length and depth, location, minimum and background Bx value, coil factor and field used for sizing. Items in the list can be deleted by pressing the red cross symbol or edited by pressing the green pencil symbol. The numbering of the defects is chronological.

Figure 4-23 Defects list box

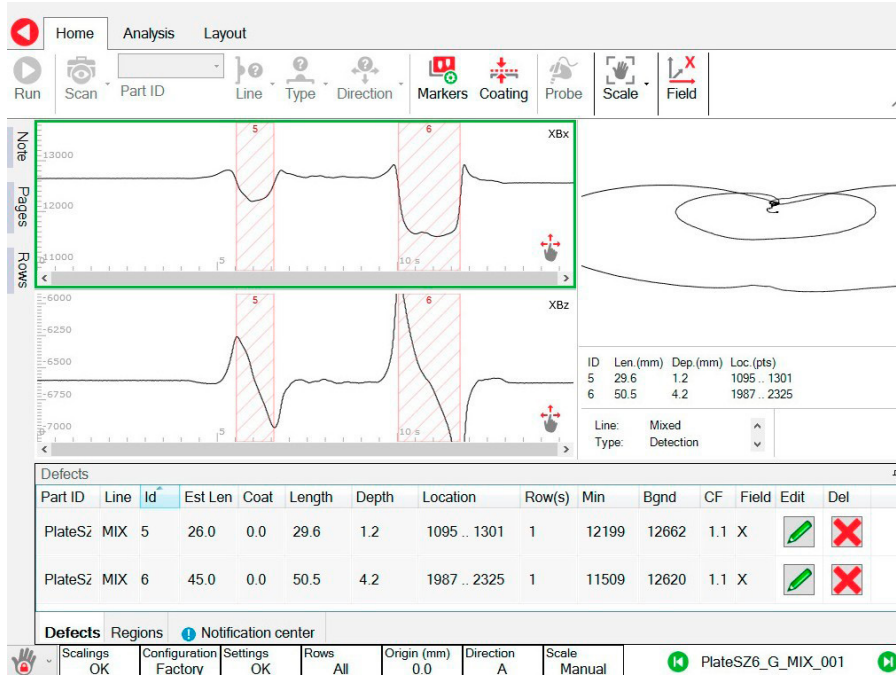

Adding a Region

Creating a region adds a color coded highlight over the Bx and Bz signals. For example, a signal feature corresponding to a seam weld could be highlighted in purple.

Figure 4-24 Adding a region

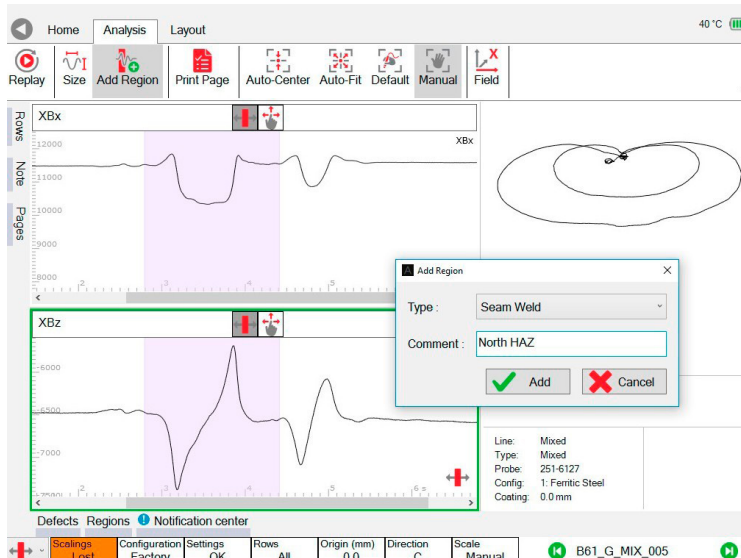

1. Zoom in on your data.
2. Press **Add Region**.
3. Select an area of data by left-click and mouse move (or drag a finger on a touchscreen) across either the Bx or Bz trace.
4. Add a region type.
5. Add a comment if required.
6. Press **Add** to keep the region or **Cancel** to remove it.
7. The region can be edited by pressing the **Regions** tab along the bottom of the screen.

Regions List Box

The regions list box contains information relating to regions added to the current page, and any associated comments. To add a region, see "Adding a Region", page 47. Information includes region type, position on the plot, color coding and any user comments. Items in the list can be deleted by pressing the red cross symbol or edited by pressing the green pencil symbol.

Figure 4-25 Regions list box

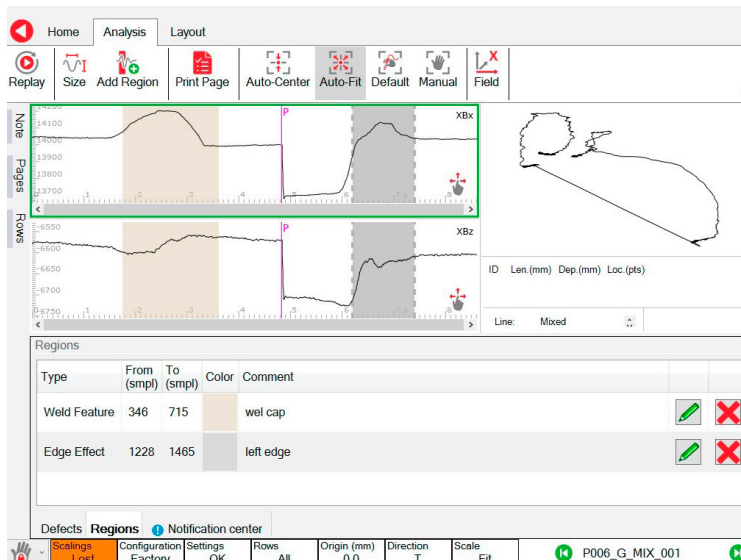

Creating an Automated Report

An automated report can be generated. This one-page report contains the following information for the current page of data:

- Site, component, date, operator name, etc.
- A screenshot of the signals as displayed, zoomed and scaled.
- Defects found.
- Instrument settings and probe details.
- Operator name.
- A place for the operator to sign.

Figure 4-26 ACFM Page Report

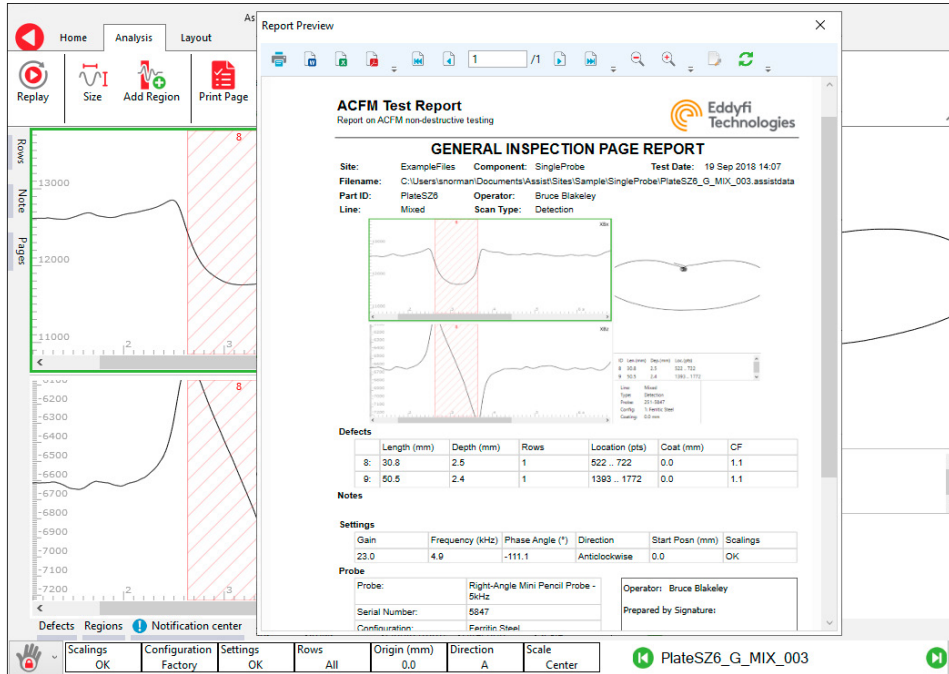

To create a report:

1. Zoom in on the part of the signal of interest. Adjust the scale if necessary.
2. Press **Print Page** on the **Analysis Ribbon** to preview the report.
3. To save the report, press one of the **Save-To** buttons in the preview ribbon (Word, Excel or PDF). A default file name will be provided, you can accept or change this, then press **OK** to save.

The report is saved in the same folder as its associated page of data. PDF reports can be reviewed later in the backstage Documents section for the current selected component.

Layout ribbon

The layout ribbon becomes active when twin-field or array probes are used. It allows the user to configure the screen to simultaneously display both fields and/or contour plots.

Figure 4-27 Layout ribbon

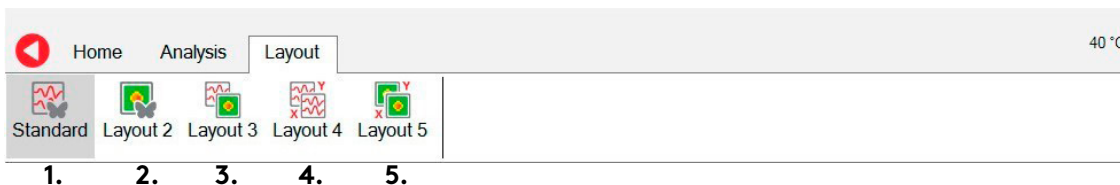

The layout ribbon has five options:

1. Standard layout
2. Layout 2
3. Layout 3
4. Layout 4
5. Layout 5

These are described in detail below.

Standard Layout

The Bx, Bz and butterfly plots are arranged in the normal manner. The Y-field is toggled with the Field button on the Analysis ribbon.

Figure 4-28 Standard view

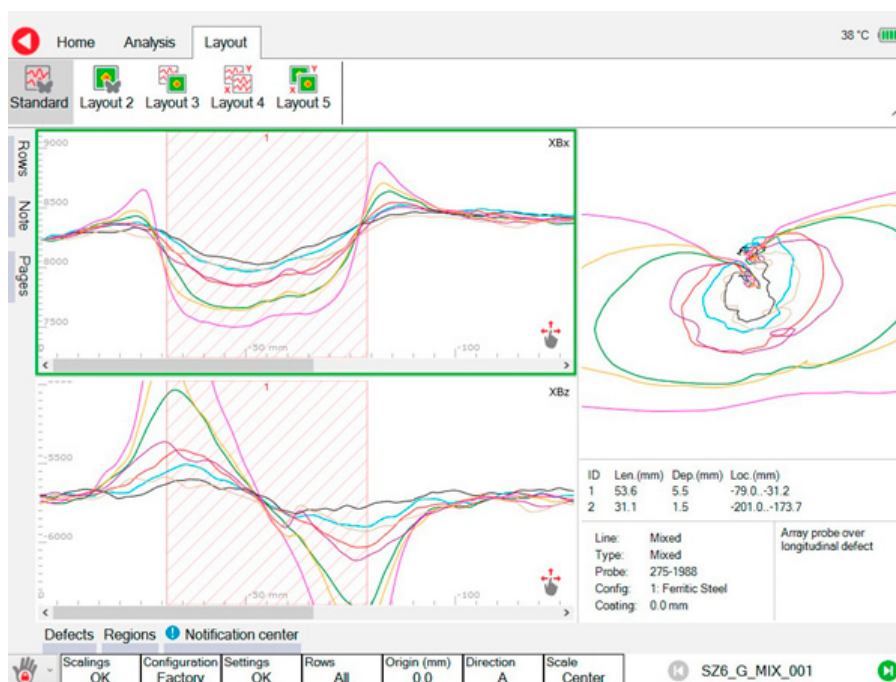

Layout 2

C-scans (contour plots) are presented for the Bx and Bz signals if array data is available. The butterfly plot is presented in the normal manner but with multiple lines corresponding to the individual array rows.

Figure 4-29 Layout 2

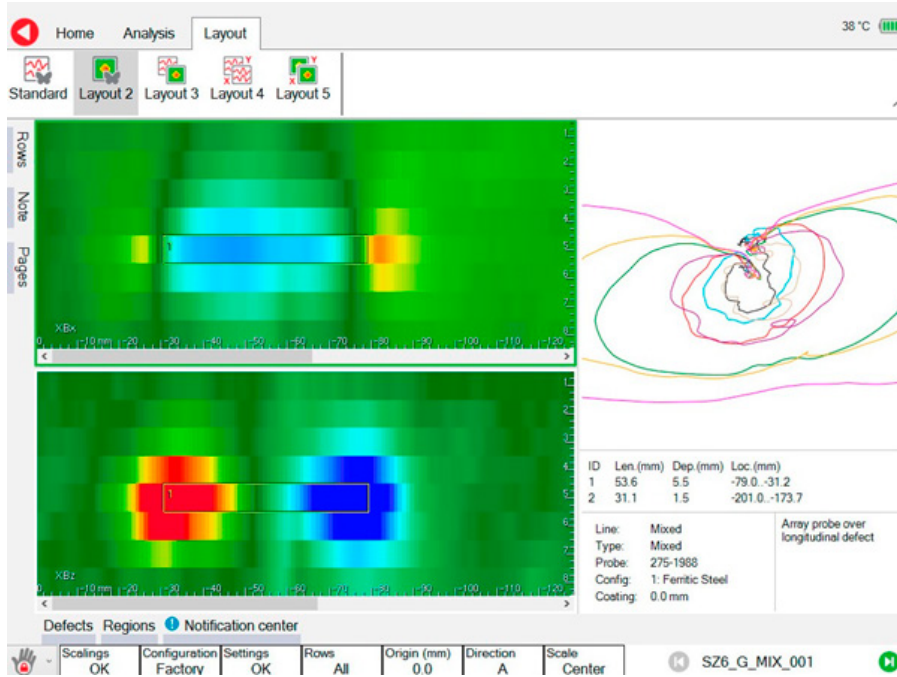

Layout 3

The Bx and Bz traces are positioned on the left. The Bx and Bz C-scans are positioned on the right. For probes that have more than one field, the desired field to display can be chosen using the **Field** button on the **Analysis Ribbon**.

Figure 4-30 Layout 3

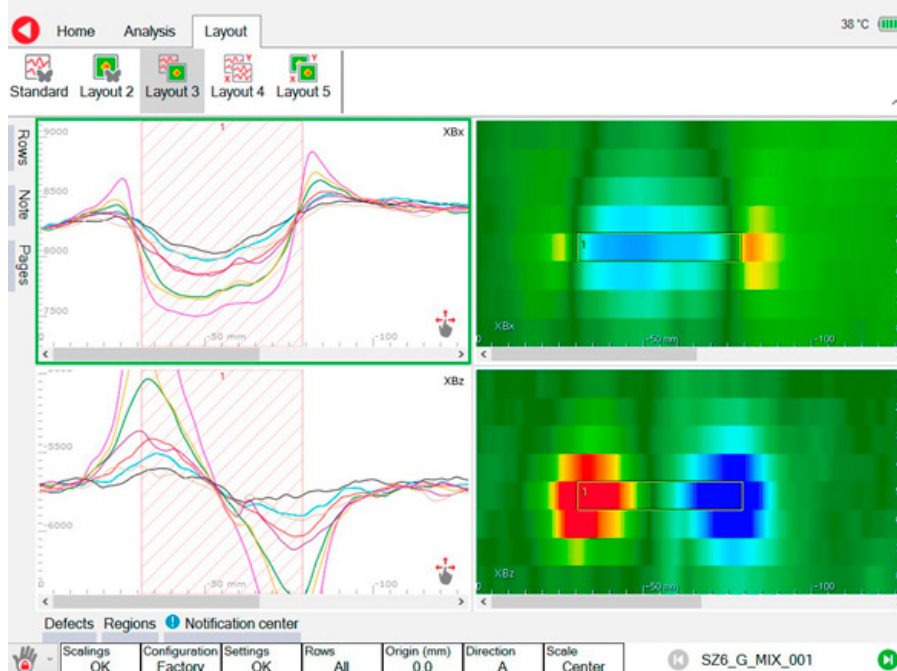

Layout 4

For probes that have more than one field, this layout enables data from both X and Y fields to be displayed at the same time. The X-field Bx and Bz traces are placed on the left. The Y-field By and Bz traces are placed on the right.

Figure 4-31 Layout 4

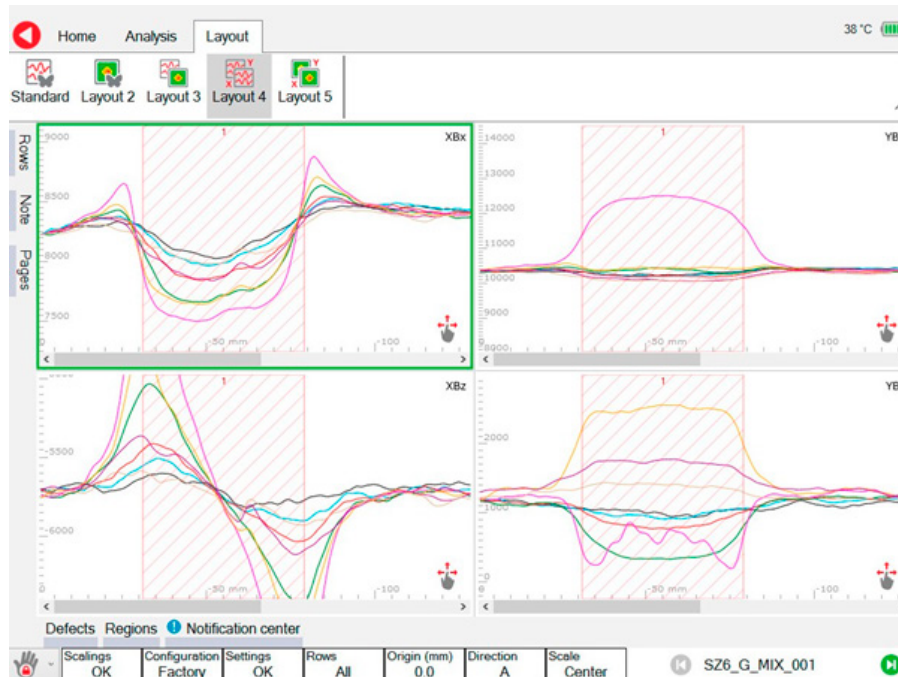

Layout 5

For probes that have more than one field, this layout enables data from both X and Y fields to be displayed at the same time. The X-field Bx and Bz C-scans are placed on the left. The Y-field By and Bz C-scans are placed on the right.

Figure 4-32 Layout 5

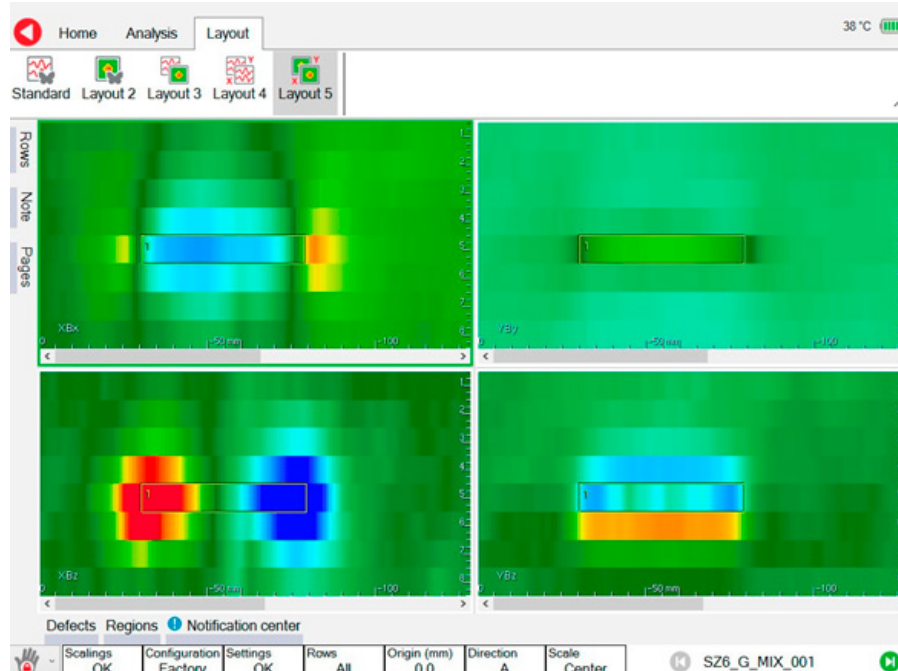

Manipulating C-scan Appearance

The C-scans simultaneously map the data from all rows. Background values are green, lower values are blue and higher values are red. Measured defects are displayed as yellow numbered rectangles. In layouts with traces or butterfly views the Bx and Bz signals can be moved up and down the screen by left-click and mouse move. A similar behaviour can be achieved in all layouts using the cursor keys. In these cases, moving the Bx or Bz signal will move the color spectrum towards the reds or towards the blues. Increasing or decreasing the Bx or Bz data scales away from the Probe Default (most commonly by using the Fit auto-scale mode) will change the magnification of the depth of the defect on the C-scan. Also zooming and panning on the x-axis will affect the appearance of the C-Scan. The combination of moving, scaling and resizing can be used to optimise the C-scan images before creating a report.

Keyboard shortcut keys

The following keyboard shortcuts can be used to control aspects of ASSIST. When a physical keyboard has been connected to an Amigo2 via one of the USB ports, these shortcuts can also be used.

| Amigo2 Function | Keyboard Shortcut |
|--|-------------------|
| Left arrow | Left arrow |
| Up arrow | Up arrow |
| Right arrow | Right arrow |
| Down arrow | Down arrow |
| Add clock/linear marker | Space |
| Add general marker | Return |
| Next scan direction set to Anticlockwise | A |
| Next scan direction set to Clockwise | C |
| Next scan direction set to Transverse | T |
| Next scan direction Unset | U |
| Pause/resume acquisition | H |
| Page First | I |
| Page Last | L |
| Page Next | N |
| Page Previous | P |
| Replay begin | Y |
| Replay faster | > |
| Replay slower | < |
| Replay stop | S |
| Run | R |
| Scale mode to Center | V |
| Scale mode to Fit | F |
| Scale mode to Probe Default | D |
| Select next keyboard mode | K |
| Select next scale mode | F12 |
| Select next view | Alt+F7 |
| Toggle show & pin Defects panel | Ctrl+D |
| Marker setup | Ctrl+C |
| Toggle show & pin Notes panel | Ctrl+N |
| Edit origin | Ctrl-O |
| Toggle show & pin Pages panel | Ctrl+G |
| Toggle show & pin Regions panel | Ctrl+R |
| Toggle show & pin Rows panel | Ctrl+W |
| Stop | S |

| Amigo2 Function | Keyboard Shortcut |
|--------------------------------|-------------------|
| Toggle Clockwise/Anticlockwise | W |

Modifying Keyboard Shortcuts

In the System preferences of the backstage, tap the Keyboard button.

Figure 4-33 Keyboard Shortcuts

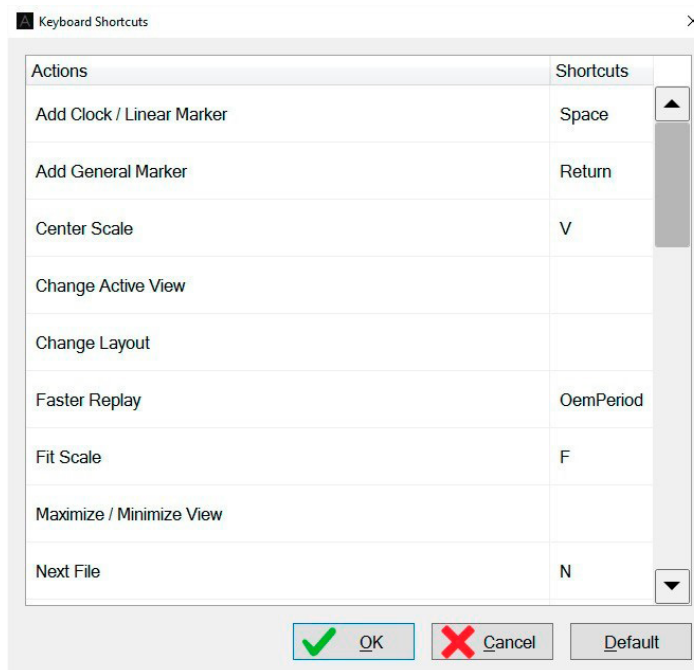

Updating and upgrading the software

Method

Reinstalling the Software

To reinstall Assist, simply follow the instructions from the Installation Wizard.

Note When installation is complete, Windows Program Compatibility Assistant might require that you confirm that Assist installed correctly. Simply click This program installed correctly.

Figure 4-34 Launching the Setup wizard

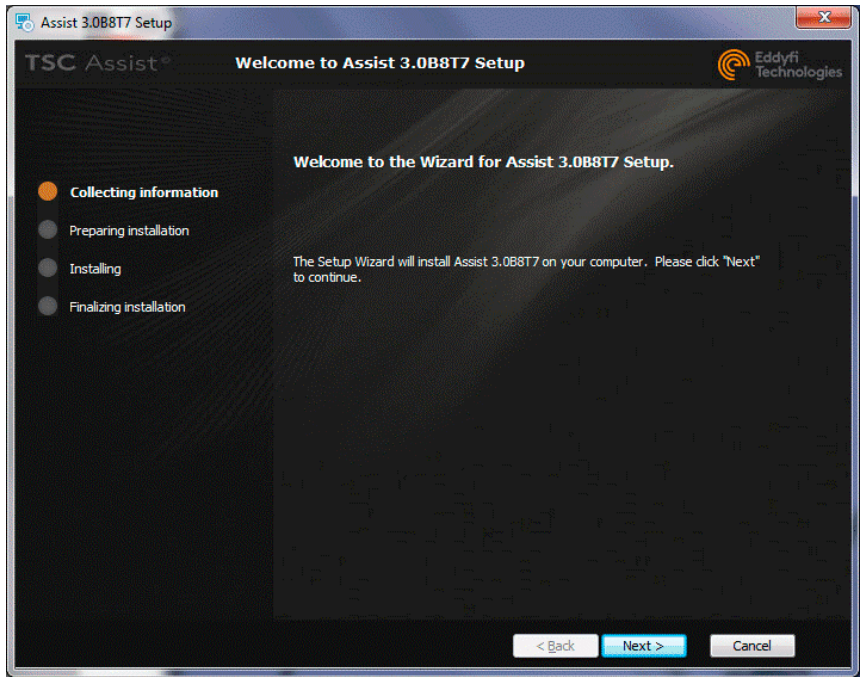

Figure 4-35 Accepting the license agreement

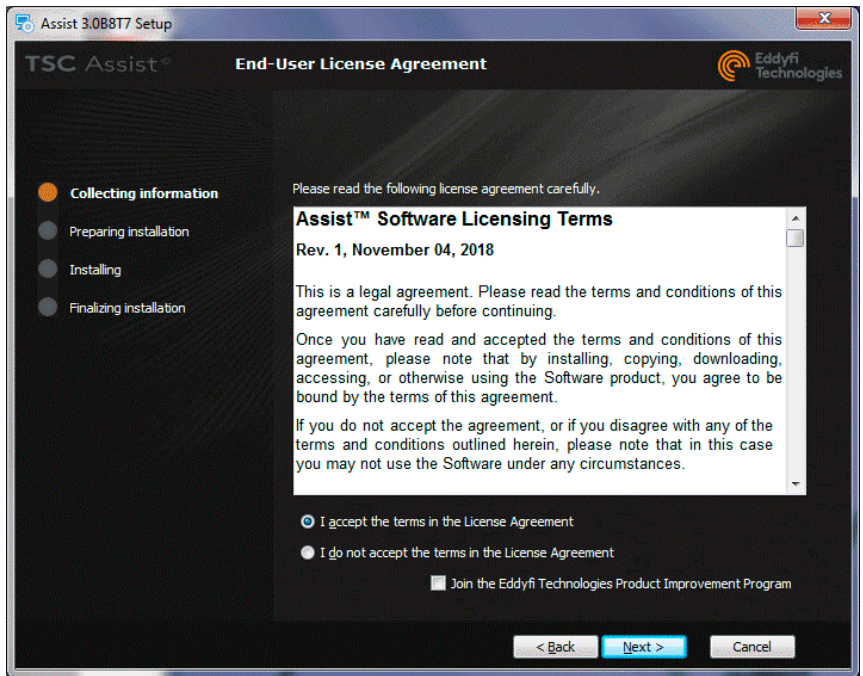

Figure 4-36 Installing the software

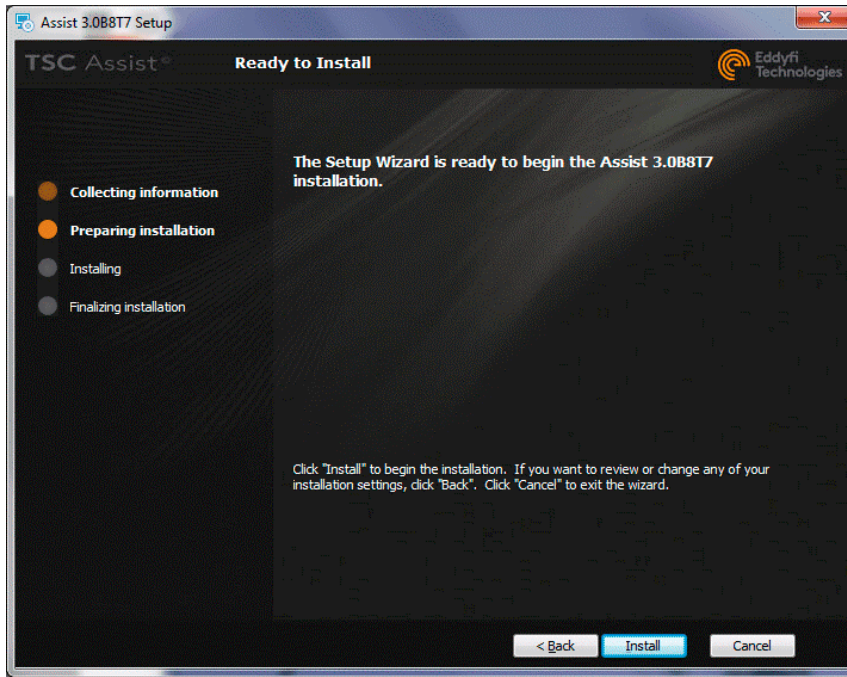
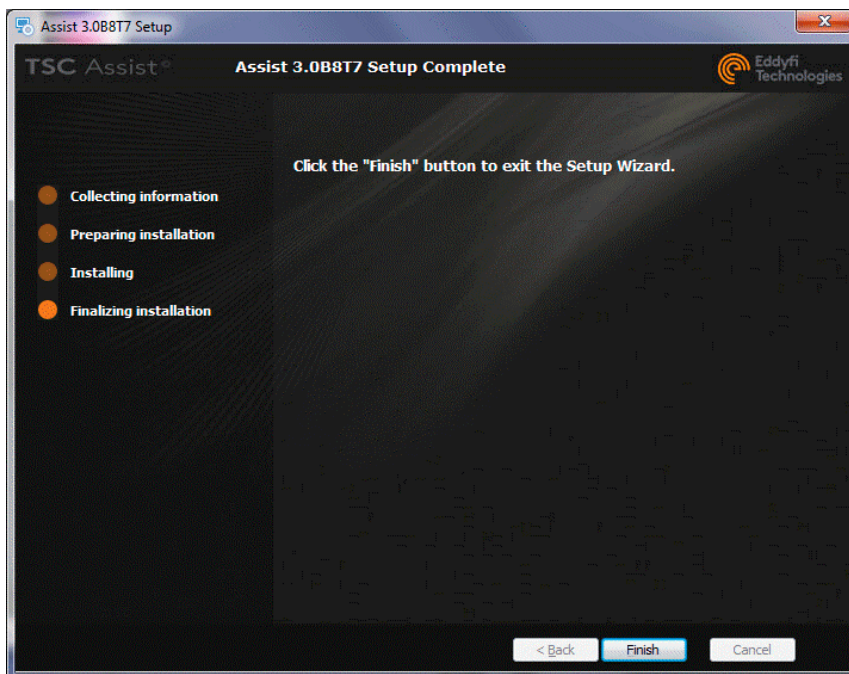

Figure 4-37 Finishing the installation



Figure 4-38 Finish the installation



Click **"This program installed correctly"**

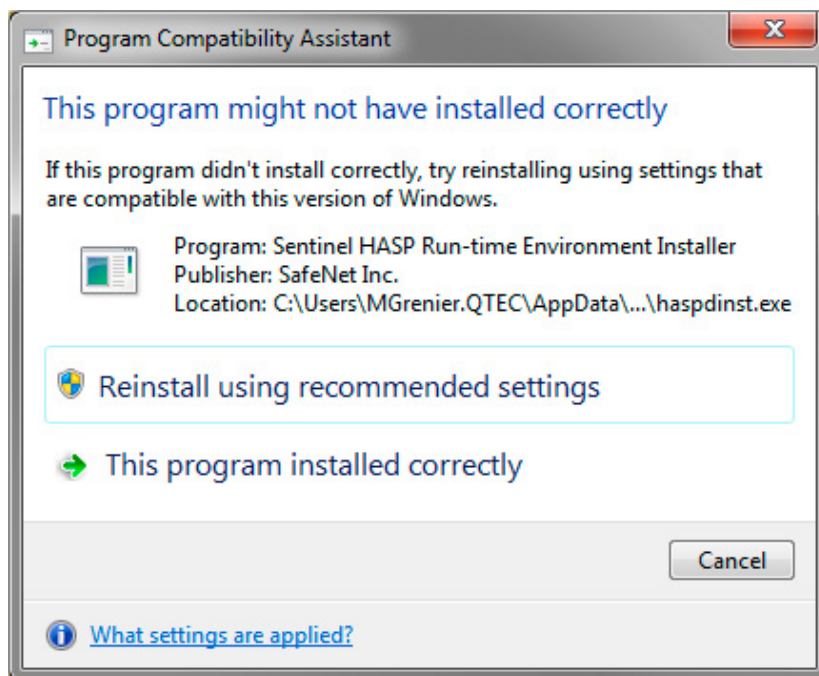

Chapter 5

Troubleshooting

Safety device trips

The Safety Trip device in the topside unit, and the RCD in the power input cable, are sensitive and may on occasion trip when there is no fault present. If either safety system trips, first see if there are any obvious causes of the problem such as a cut or damaged umbilical, an unplugged cable or if the ROV team report a problem or are working on the ROV.

If no obvious reason for the fault is found, warn the diver to remain at least 1m from the subsea equipment, or the ROV team to ensure no-one is working on the ROV wiring, and try resetting the trip.

If there are no further trips or problems, then the work may be resumed.

If at any point the trip will not reset or repeatedly trips, then the work must be immediately suspended, and the cause of the problem found and rectified.

The information in this document is accurate as of its publication. Actual products may differ from those presented herein. © 2019 Eddyfi UK Ltd. Eddyfi, TSC, Amigo2, PACE, U41 and their associated logos are trademarks or registered trademarks of Eddyfi in the United States and/or other countries. Eddyfi reserves itself the right to change product offerings and specifications without notice.

www.eddyfitechnologies.com

info@eddyfi.com

